



Research Article

INVESTIGATION OF HOLE SHAPE EFFECT ON STATIC ANALYSIS OF PERFORATED PLATES WITH STAGGERED HOLES

Authors: Mustafa Halûk Saraçoğlu*, Fethullah Uslu , Uğur Albayrak 

***Corresponding Author:** mhaluk.saracoglu@dpu.edu.tr

To cite to this article: Saraçoğlu, M., H., Uslu, F., Albayrak, U., (2021). Investigation of Hole Shape Effect on Static Analysis of Perforated Plates with Staggered Holes, International Journal of Engineering and Innovative Research, 3(2), p 133-144.

DOI: 10.47933/ijeir.883510

To link to this article: <https://dergipark.org.tr/tr/pub/ijeir/archive>



INVESTIGATION OF HOLE SHAPE EFFECT ON STATIC ANALYSIS OF PERFORATED PLATES WITH STAGGERED HOLES

Mustafa Halûk Saraçoğlu^{1*}, Fethullah Uslu¹, Uğur Albayrak²

¹Kütahya Dumlupınar University, Faculty of Engineering, Department of Civil Engineering, Kütahya, Turkey.

²Eskişehir Osmangazi University, Faculty of Engineering, Department of civil engineering, Eskişehir, Turkey.

*Corresponding Author: mhaluk.saracoglu@dpu.edu.tr

(Received: 19.02.2021; Accepted: 10.04.2021)

<https://doi.org/10.47933/ijeir.883510>

ABSTRACT: In this paper, a series of analysis with finite element method was carried out with varying hole shapes of perforation as well as plate dimensions. Eight different models about holes that number of edges at the hole is four to infinite namely circular holes was presented. Then the analyze results of these models with different boundary conditions as fixed supported and simply supported at four edges were compared. In this study it has shown that when the number of edges for a hole is infinite, in other words when the perforation of the plate is circular, mid-point deflection is decreasing according to the other perforation styles. And also analyze results of eight different models of perforated plates are given in tables and comparative graphs.

Keywords: Ansys, Noncircular hole, 60° staggered perforated, Square thin plate, Mid-point deflection, Equivalent (von Mises) stress.

1. INTRODUCTION

The square thin plates made of steel are structural elements that are largely used in civil and mechanical engineering. In some cases they are also used as perforated plates by composing holes on the plates. The perforated plates have some advantages over non-perforated plates. These elements have many different usage areas in the automotive and air industries as vehicles and aircrafts manufacturing, and also furniture manufacturing, construction industry, distilling, food refining, mining and plenty of more uses.

Perforated steel plates have technical advantages over expanded metal, welded wire, woven wires, which can be used as an alternative to these perforated elements. The functional capacity of perforated plates compared to these other materials is distinguished when considering filtration, ventilation, radiation protections, sound absorption, and others. One of the advantage of perforated plates is its variability in allowing a variation of combinations of open areas in a single sheet.

There are many studies about analysis of perforated plates in literature. In the studies generally experimental and numerical methods have been used. Numerical methods that are using finite element method is the most preferred one among the solutions [1-5]. Perforated plates with in-plane loading are also interested with some researchers [6], [7].

Bailey and Hicks is developed a theoretical method for determining the elastic behaviour of end-loaded plates completely perforated with closely spaced circular holes forming a square or diagonal pattern [8].

For perforated plates which have many holes, the shape of the holes will affect the value and location of the maximum stresses. In this subject Jafari and Jafari investigated the stress distribution around holes with different shapes in an infinite composite plate under uniform heat flux. In their study, the effect of various parameters on stress distributions around a different hole in an infinite composite plate was separately investigated [9].

Pascu et.al, describe the method of calculating the forces which appear at the bending of perforated plates with holes of different shapes and placed in different patterns in their study [10].

Konieczny et.al., presents an analysis of an isotropic circular axisymmetric perforated plate loaded with concentrated force applied in the geometric center of the plate using finite element software ANSYS [11], [12].

Kalita and Halder, investigated the deflection and stresses for isotropic and orthotropic plates with central circular and square cutout under transverse loading by using finite element package ANSYS [13].

Atanasiu and Sorohan, studied the stress distribution in a circular plate of Plexiglas with a diameter of 300 mm and thickness of 10 mm, perforated by 96 circular holes of diameter 12 mm, arranged in a grid of squares of 24 mm by using the finite element analysis (FEA) and experimentally. Load is acting through a central concentrated load and distributed load and considered as simply supported on its exterior margin. And also they studied a non-perforated plate of the same supports, the same material and the same load condition to make a comparisons between the behaviour of the two types of plates [14].

Andh et. Al., investigated the stress analysis of finite plate with special shaped cut out for stress distribution and Stress Concentration Factors (SCF) by using the finite element method and photoelasticity. And also an experimental investigation is taken to study for the stress analysis of plates with special shaped cut outs [4].

Rayhan performed a finite element analysis on the buckling behavior of a simply supported quasi-isotropic symmetric composite panel with central circular cutouts, reinforced with stiffeners on both sides of the cutouts under uniaxial, biaxial and combined loading conditions by using popular commercial software code Ansys [19].

Jafari et al., investigated the optimal values of effective parameters on the stress distribution around a circular/elliptical/quasi-square cutout in the perforated orthotropic plate under in-plane loadings. They use the PSO algorithm in their study to determine the optimal design variables to increase the strength of the perforated plates. And also finite element method (FEM) was employed to examine the results of the present analytical solution [20].

Lorenzini et. al., studied the influence of the type and shape of the hole in the behavior of buckling perforated steel plates numerically [15].

Helbig et. al., investigated the influence of the shape, size and type of the opening in the buckling behavior of a thin steel plate by developing some computational models using ANSYS software [16].

There are not much works about various shaped holes for perforations in perforated plates, justifying the present research. However, here only the perforated thin square plate bending behavior is studied, for investigating about various hole type effect that were not much performed previously. The present work employs the computational modeling for the study of fixed supported and simply supported thin steel perforated square plates subjected to the uniformly distributed load and its self-weight.

2. METHODS

The Plates are solid bodies bounded by two parallel planes and the thickness of the plate which is the separation between these two parallel planes is small compared with the lateral dimensions (Figure 3). They are solid bodies but it is often not necessary to model plates using three-dimensional elasticity theory. Stress and strain analysis of three dimensional plates under plane stress or plane strain can be treated as two dimensional problems [17].

Compatibility equations and boundary conditions must be provided together in the solution of equilibrium equations of two dimensional problems. By neglecting the components of body force per unit volume, the equation of equilibrium for forces in the x- direction and y-direction is follows respectively:

$$\frac{\partial \sigma_x}{\partial x} + \frac{\partial \sigma_{xy}}{\partial y} = 0 \quad (1)$$

$$\frac{\partial \sigma_y}{\partial y} + \frac{\partial \sigma_{xy}}{\partial x} = 0 \quad (2)$$

The compatibility equation in terms of stress components is as follows:

$$\left(\frac{\partial^2}{\partial x^2} + \frac{\partial^2}{\partial y^2} \right) (\sigma_x + \sigma_y) = 0 \quad (3)$$

Substituting the stress components in equation 1, 2 and 3 by displacements u and v is as follows:

$$\frac{\partial^2 u}{\partial x^2} + \frac{(1-\nu)}{2} \left(\frac{\partial^2 u}{\partial y^2} \right) + \frac{(1+\nu)}{2} \left(\frac{\partial^2 v}{\partial x \partial y} \right) = 0 \quad (4)$$

$$\frac{\partial^2 v}{\partial y^2} + \frac{(1-\nu)}{2} \left(\frac{\partial^2 v}{\partial x^2} \right) + \frac{(1+\nu)}{2} \left(\frac{\partial^2 u}{\partial x \partial y} \right) = 0 \quad (5)$$

In this equations ν is the Poisson's ratio of the material. By reducing the problem to a single function $\phi(x,y)$ which can take place of the two displacement functions u and v and satisfies the equations 4 and 5, solution can be defined as serial solutions. This displacement function $\phi(x,y)$ can be defined as follows:

$$u = \frac{\partial^2 \phi}{\partial x \partial y} \tag{6}$$

$$v = - \left[(1-\nu) \left(\frac{\partial^2 \phi}{\partial y^2} \right) + 2 \left(\frac{\partial^2 \phi}{\partial x^2} \right) \right] / (1-\nu) \tag{7}$$

In this way, a series of solutions are obtained for equilibrium equations. The exact solution of the problem is also the solution that provides the compatibility equations. Thus, if the body force of the plate is neglected, the solution of a two-dimensional problem is reduced to finding the solution that provides the boundary condition of equation (8).

$$\frac{\partial^4 \phi}{\partial x^4} + 2 \left(\frac{\partial^4 \phi}{\partial x^2 \partial y^2} \right) + \frac{\partial^4 \phi}{\partial y^4} = 0 \tag{8}$$

By using a combination of the kinematic, constitutive, force resultant, and equilibrium equations, the classical plate equation of Kirschhoff can be derived as in equation (9).

$$\frac{\partial^4 w}{\partial x^4} + 2 \left(\frac{\partial^4 w}{\partial x^2 \partial y^2} \right) + \frac{\partial^4 w}{\partial y^4} = \frac{q}{D} \tag{9}$$

In this equation w is the small transverse (out-of-plane) displacement of a thin plate, q is the distributed load acting transversely on the plate as shown in figure 3 and D is the flexural rigidity of the plate defined as in equation [10].

$$D = \frac{E h^3}{12(1-\nu^2)} \tag{10}$$

E is the Young's modulus, h is the thickness of the plate and ν is the Poisson's ratio of the plate material.

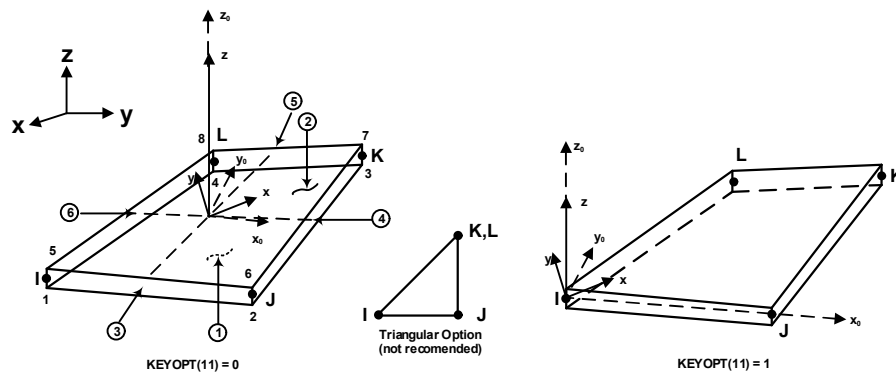

Figure 1. Geometry of SHELL181 finite element in ANSYS [18].

The ANSYS finite element software is also used in the modeling of plates. For this purpose, firstly, the material properties and the geometric properties of the element are defined and then plate is divided into finite elements. SHELL 181 element which is a 4-Node Structural Shell is selected from ANSYS library.

“Shell181” is a 4-node structural finite element in the program element library as shown in Figure 1. The element has six degrees of freedom at each node: translations in the nodal x , y and z directions and rotations about the nodal x , y and z -axes.

Firstly, the geometry of the problem is defined in the program and a model is created. Then material properties and elements are defined. For the calculations the definition of static analysis is made. Fixed supported and simply supported boundary conditions of the perforated square plates are defined separately. A load of uniformly distributed $q=1$ kN/m² load to the plate surface and its own weight is applied at the $-Z$ direction. After these processes were completed, static analysis was performed and the results of deformation were obtained from the program.

Stress output for SHELL181 element is as follows:

σ_x is normal stress due to X axis (SX)

σ_y is normal stress due to Y axis (SY)

σ_{xy} is shear stress (SXY)

3. NUMERICAL EXAMPLES

Three different dimensioned square thin perforated plates have analyzed. One dimension of square plate is taken as 300 mm, 450 mm and 600 mm. In all of these three sets of plate examples, thickness to length ratio was taken constant as 1/150 in all examples to provide thin plate assumptions. So that thickness of the plates are 2 mm, 3 mm and 4 mm respectively (Table 2).

The plate models are assumed made of steel material. The material parameters of the steel plates are shown in Table 1.

Table 1. Material properties

Property	Value
Young's modulus, E (GPa)	200
Poisson's ratio, ν	0.3
Mass density, ρ (kg/m ³)	7850

Every set of plates has the same open area percentage in itself as shown in Table 3 but different hole shapes. Area of a one hole is defined as $A = \frac{1}{4} n k^2 \cot\left(\frac{\pi}{n}\right)$. In this equation n is the number of edges and k is the length of a one edge in the polygon.

Table 2. Parameters of perforated square plates

Length a (mm)	Thickness h (mm)	Number of holes	Open area percentage (%)
300	2	264	33.18
450	3	634	35.41
600	4	1166	36.63

For each set of plate example, eight different models and a non-perforated plate have been arranged as shown in Table 3. In the models number of edges increases from four to infinite. When the number of edges are four, there are square holes at the perforated plate. When the number of edges are infinite, there are circular holes at the perforated plate (Figure 2).

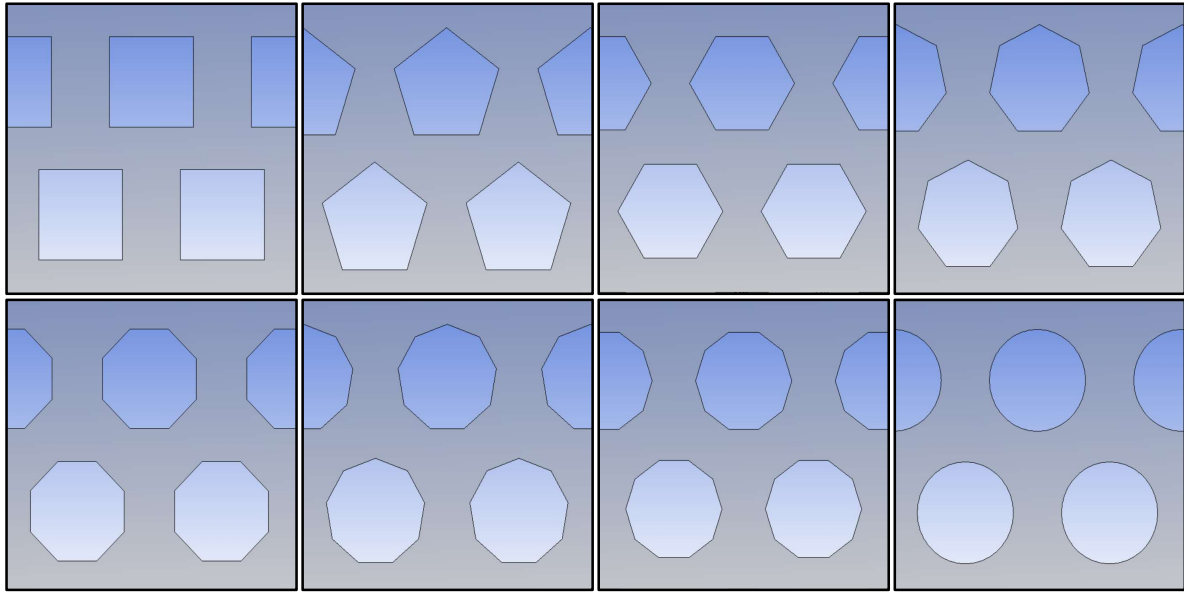

Figure 2. Perforated plate models.

Coordinates, loads and perforation schema for investigated plate models is shown in Figure 3. As shown in figure loads are applied at the $-Z$ direction and magnitude of uniformly distributed load is $q=1 \text{ kN/m}^2$. Perforated square plate’s own weight is also considered.

This study investigates which the hole geometry has the minimum displacements and stresses. For this purpose 600 staggered pattern distribution which is one of the most popular shape in the perforated metal industry has been used.

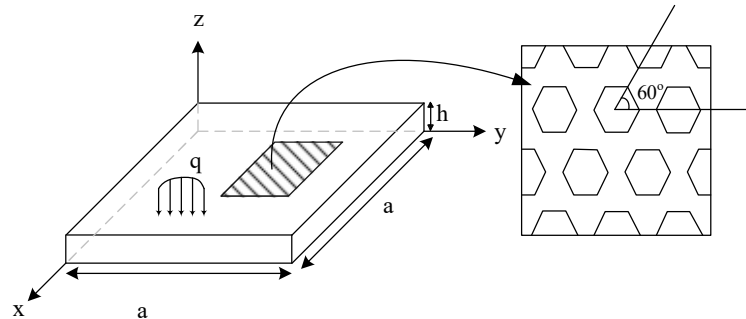

Figure 3. Coordinates, loads and perforation schema for plate models.

Stress and displacement analysis of perforated square plates are investigated. Midpoint deflections and critical stresses are calculated. Two different boundary conditions as simply supported and fixed supported are considered. Hole information for perforated plates is shown in Table 3. Since the number of holes is constant in all models, the percentage of open hole areas in the plates are also constant.

Table 3. Information for perforated plate models.

Model no	Model name	Number of edges on hole	Length of edge on hole (mm)
1	Square	4	10.634723
2	Pentagon	5	8.107775
3	Hexagon	6	6.597817
4	Heptagon	7	5.578776

5	Octagon	8	4.839755
6	Nonagon	9	4.277282
7	Decagon	10	3.833930
8	Circle	∞	0.000000
9	Non-perforated	-	-

4. RESULTS AND DISCUSSION

The bending behavior of various perforated plates were numerically simulated by means of the ANSYS software, which is based on the finite element method. Three sets of perforated square plates and eight different models for each set together with non-perforated plate are investigated.

Table 4. Mid-point deflections of perforated square plates (mm).

a(mm) edges	Fixed Supported			Simply Supported		
	300	450	600	300	450	600
4	-0.10652	-0.18747	-0.28346	-0.37807	-0.64420	-0.96540
5	-0.10240	-0.17872	-0.26827	-0.36466	-0.61354	-0.90736
6	-0.10127	-0.17645	-0.26437	-0.36083	-0.60614	-0.89488
7	-0.09985	-0.17335	-0.25930	-0.35587	-0.59588	-0.87818
8	-0.09941	-0.17248	-0.25767	-0.35429	-0.59276	-0.87257
9	-0.09915	-0.17187	-0.25669	-0.35340	-0.59089	-0.86950
10	-0.09899	-0.17153	-0.25611	-0.35285	-0.58972	-0.86755
∞	-0.09856	-0.17064	-0.25468	-0.35130	-0.58676	-0.86284
0	-0.08079	-0.12927	-0.18314	-0.26054	-0.41701	-0.59085

Mid-point deflections of all sets and models of perforated square plates are shown in Table 4. Calculations indicate that the maximum deflection of the perforated square plate under distributed load acting perpendicular to the plate surface is at the mid-point of it. From the table one can see that mid-point deflections of perforated plates are greater than non-perforated ones. And also when the number of edges increases mid-point deflections are decreases. The difference of mid-point deflections between the models are decreases when the number of hole edge increases and this ratio is the biggest between non-perforated and perforated ones. This behavior is similar for fixed supported and simply supported boundary conditions but the difference between non-perforated plates is much bigger for simply supported models.

As an example mid-point deflections of perforated square plates for a=300 mm and h=2 mm is shown in the Figure 4.

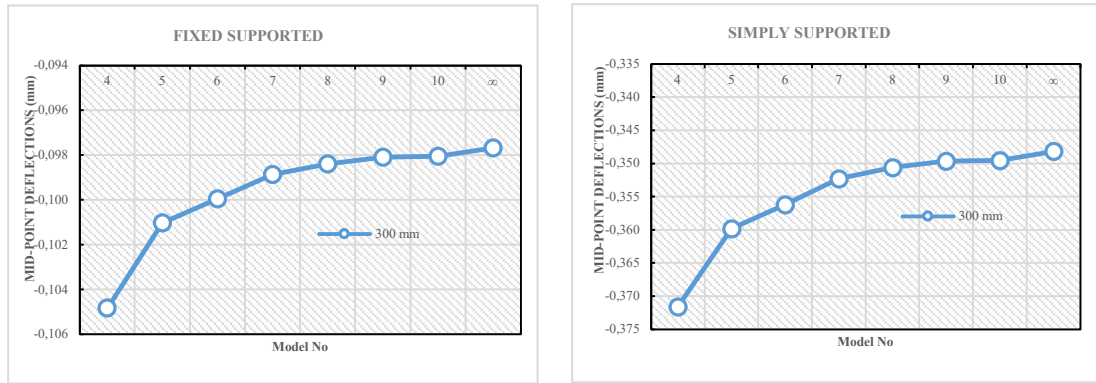

Figure 4. Mid-point deflections of perforated square plates for a=300 mm.

The values in the figure are for perforated square plates with fixed supported and simply supported at four edges. And the mid-point deflections for perforated square plates with eight different shaped hole models are also shown at the figure.

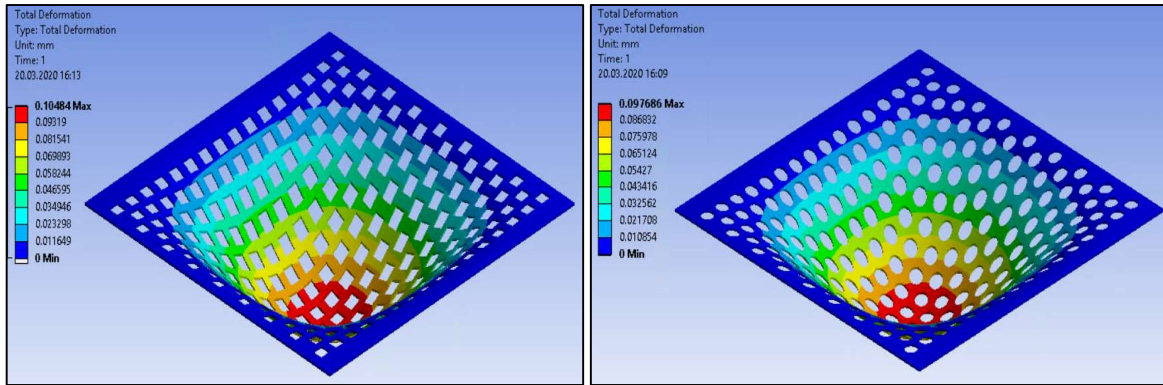

Figure 5. Mid-point deflections of perforated plates for square and circular models.

Mid-point deflections of perforated square plates which have square holes and circular holes are depicted in Figure 5. In the figure square plates have 300 mm length in one edge and have fixed supported boundary conditions at the four edges.

Table 5. Critical stresses of the plates subjected to a uniformly distributed load (MPa).

Model no	Fixed Supported				Simply Supported			
	S _y	S _x	S _{xy}	Von-Mises	S _y	S _x	S _{xy}	Von-Mises
1	10.5749	12.3315	4.0274	12.1918	13.1865	15.0102	8.7468	19.1774
2	12.4436	12.1358	3.8199	11.9058	16.8273	15.9662	8.4672	17.7789
3	12.6162	10.5776	3.6768	11.9822	18.2594	14.0572	8.1429	17.0617
4	10.6838	9.9117	3.3514	10.3062	14.8732	14.9453	7.5134	15.4733
5	9.5229	9.7359	3.5400	10.0716	13.0527	13.4008	7.1670	14.9605
6	10.3149	10.1714	3.5512	9.9939	14.5713	13.5096	7.0957	14.4206
7	9.6228	9.5203	3.3497	9.7380	13.0294	13.5271	7.0863	14.3009
8	8.7277	8.2747	2.9016	8.6012	12.3388	11.3666	7.0542	12.4904

As an example, maximum stresses of square plates with eight different shaped hole models for $a=300$ mm and $h=2$ mm is given in the Table 5. The values in the table are for perforated square plates with fixed supported and simply supported at four edges.

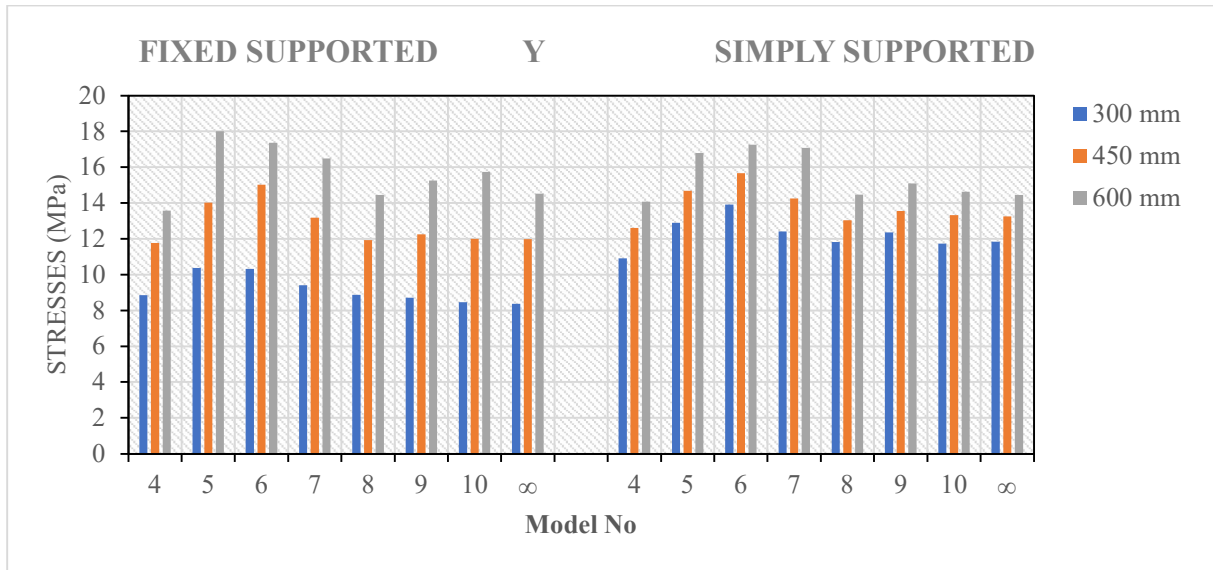

Figure 6. Absolute maximum SY stresses.

Absolute maximum SY stress values for three different sizes of square perforated plates are shown in the Figure 6. The values in the figure are for perforated square plates with fixed supported and simply supported at four edges.

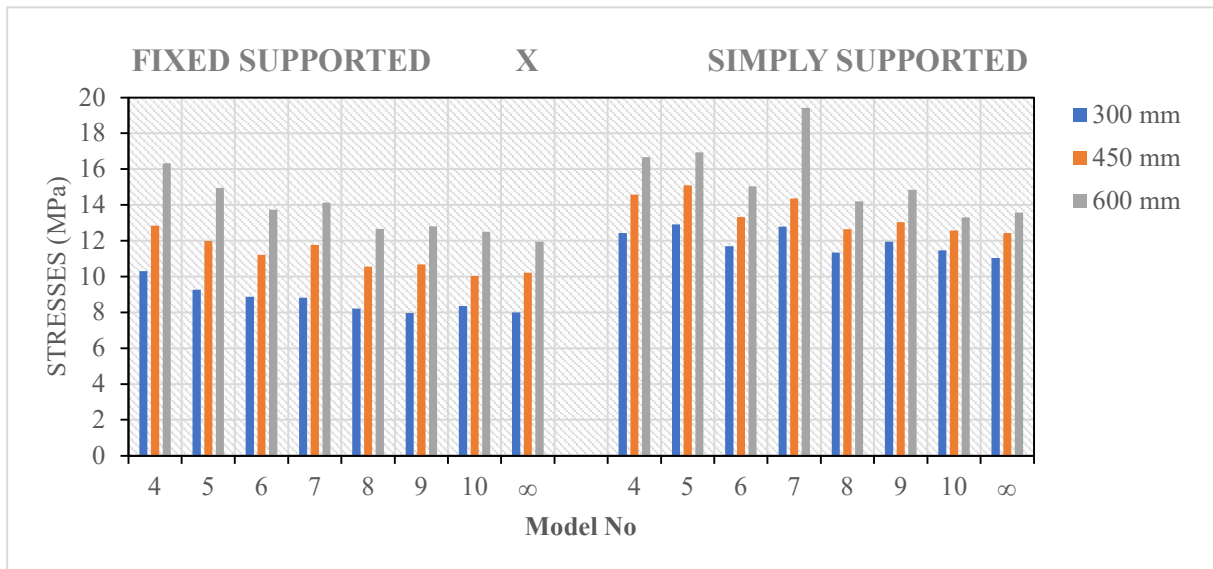

Figure 7. Absolute maximum SX stresses.

Absolute maximum SX stress values for three different sizes of square perforated plates are shown in the Figure 7. The values in the figure are for perforated square plates with fixed supported and simply supported at four edges.

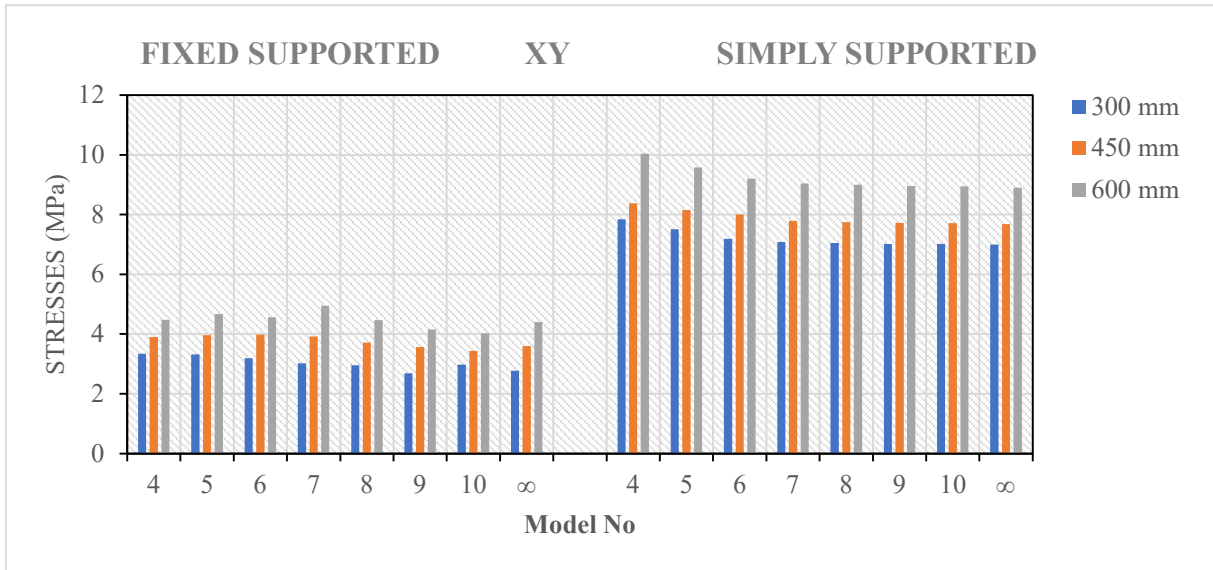

Figure 8. Absolute maximum SXY stresses.

Absolute maximum SXY stress values for three different sizes of square perforated plates are shown in the Figure 8. The values in the figure are for perforated square plates with fixed supported and simply supported at four edges.

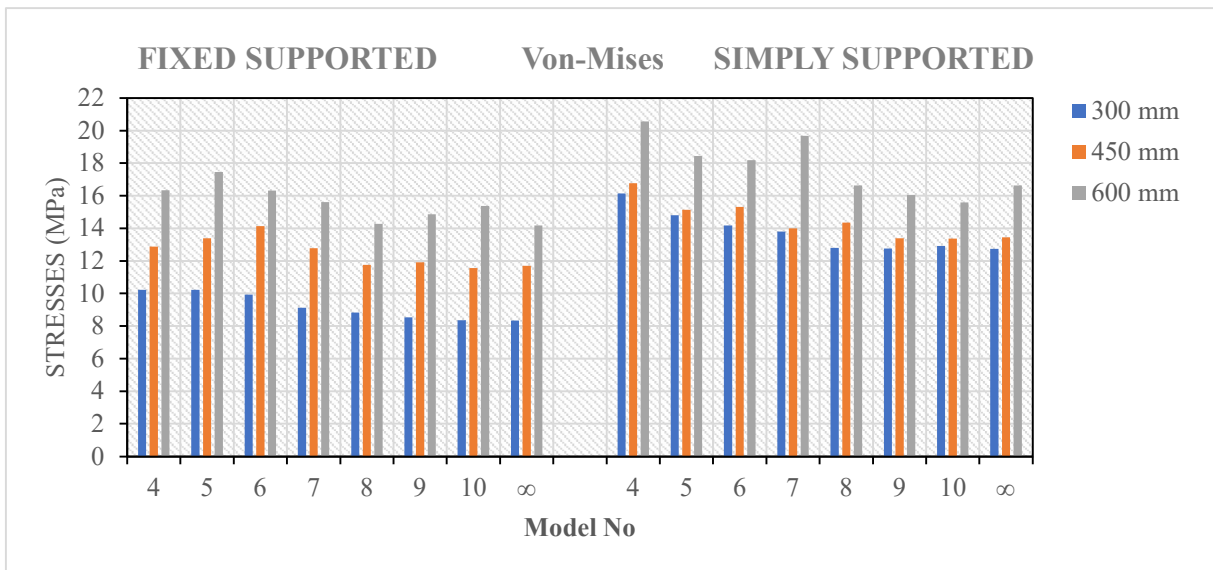

Figure 9. Absolute maximum equivalent Von-Misses stresses.

Absolute maximum equivalent Von-Misses stress values for three different sizes of square perforated plates are shown in the Figure 9. The values in the figure are for perforated square plates with fixed supported and simply supported at four edges.

5. CONCLUSIONS

Bending of perforated square thin plates made of steel with three different thickness 2mm, 3mm and 4mm are investigated under self-weight and 1kN/m² uniformly distributed loads. Thickness to length ratio is constant as 1/150. The results that were obtained with numerical calculations by using ANSYS software have been compared. Every perforated plate example has the same open area percentage in itself but different hole shapes. For perforated plate

examples eight different models that has different number of hole edges from four to infinite have been arranged and also a non-perforated plate example examined to understand the effect of perforation. The aim of the study is investigating the hole geometry which makes the minimum displacements and stresses on perforated plate. For examined problems the most commonly used pattern distribution 600 staggered has been used.

It is important to highlight that the present work has shown that when the number of edges is infinite, in other words when the perforation of the plate is circular, it has more advantage than the other perforation styles. This investigation is made with defining several geometrical configurations and the total material volume of the perforated plate sets for all models were keeping constant. And also, a performance comparison among the defined hole geometries of perforated plate has been carried out.

Therefore, based on the obtained results, the importance of the geometrical evaluation in structural engineering, as well as the effectiveness of the constructional design method application in the mechanics of material problems, is evident.

The bending analysis about the effect of number of hole edges over the geometric configurations of the perforated square plates, as well as the graphical representation of the stress distribution for all plate models, can be found in this study.

REFERENCES

- [1] M. H. Saraçoğlu and U. Albayrak, "Linear static analysis of perforated plates with round and staggered holes under their self-weights," *Res. Eng. Struct. Mater.*, vol. 2, no. 1, pp. 39–47, 2016.
- [2] U. Albayrak and M. H. Saraçoğlu, "Analysis of Regular Perforated Metal Ceiling Tiles," *Int. J. Eng. Technol.*, vol. 10, no. 6, pp. 440–446, 2018.
- [3] S. Singh, K. Kulkarni, R. Pandey, and H. Singh, "Buckling analysis of thin rectangular plates with cutouts subjected to partial edge compression using FEM," *J. Eng. Des. Technol.*, vol. 10, no. 1, pp. 128–142, Mar. 2012.
- [4] U. B. Andh, S. M. Chavan, S. G. Kulkarni, and S. N. Khurd, "Stress analysis of perforated plates under uniaxial compression using FEA and photoelasticity," *Int. Res. J. Eng. Technol.*, 2016.
- [5] J. Rezaeepazhand and M. Jafari, "Stress analysis of perforated composite plates," *Compos. Struct.*, vol. 71, no. 3–4, pp. 463–468, Dec. 2005.
- [6] A. M. Sayed, "Numerical analysis of the perforated steel sheets under uni-axial tensile force," *Metals (Basel)*, vol. 9, no. 6, pp. 1–16, 2019.
- [7] M. Diany, "Effects of the Position and the Inclination of the Hole in Thin Plate on the Stress Concentration Factor," vol. 2, no. 12, pp. 8–12, 2013.
- [8] R. H. R. Bailey, "Behaviour of perforated plates under plane stress," *J. Mech. Eng. Sci.*, vol. 2, no. 2, pp. 143–165, 1960.
- [9] M. Jafari and M. Jafari, "Effect of hole geometry on the thermal stress analysis of perforated composite plate under uniform heat flux," *J. Compos. Mater.*, vol. 53, no. 8, pp. 1079–1095, 2019.
- [10] E. Pascu, A., Oleksik, M., Avrigean, "Experimental method for determining forces at bending of perforated plates," *Acta Universitatis Cibiniensis – Tech. Ser.*, vol. 69, no. 1, pp. 52–58, 2017.
- [11] H. Achtelik, G. Gasiak, and J. Grzelak, "Strength tests of axially symmetric perforated plates for chemical reactors: Part 2-Experiments," *Int. J. Press. Vessel. Pip.*, vol. 85, no. 4, pp. 257–264, 2008.
- [12] M. M. Konieczny, H. Achtelik, and G. Gasiak, "Finite element analysis (FEA) and experimental stress analysis in circular perforated plates loaded with concentrated force," *Frat. ed Integrita Strutt.*, vol. 14, no. 51, pp. 164–173, 2020.
- [13] K. Kalita and S. Halder, "Static analysis of transversely loaded isotropic and orthotropic plates with central cutout," *J. Inst. Eng. India Ser. C*, vol. 95, no. 4, 2014.
- [14] C. Atanasiu and S. Sorohan, "Displacements and stresses in bending of circular perforated plate," *IOP Conf. Ser. Mater. Sci. Eng.*, vol. 147, no. 1, 2016.
- [15] G. Lorenzini et al., "Numerical evaluation of the effect of type and shape of perforations on the buckling of thin steel plates by means of the constructional design method," *Int. J. Heat Technol.*, vol. 34, no. S1, pp. S9–S20, Jan. 2016.

- [16] D. Helbig, C. C. C. Da Silva, M. de V. Real, E. D. dos Santos, L. A. Isoldi, and L. A. O. Rocha, "Study about buckling phenomenon in perforated thin steel plates employing computational modeling and constructal design method," *Lat. Am. J. Solids Struct.*, vol. 13, no. 10, pp. 1912–1936, 2016.
- [17] Timoshenko, S, Goodier, J. N., *Theory of Elasticity*. McGraw-Hill, Newyork, USA, 1951.
- [18] A. Swanson Analysis System Inc., "ANSYS User's manual." 2005.
- [19] S.B. Rayhan, "Elastic buckling response of a composite panel stiffened around cutouts," *International Journal of Engineering, Transactions A: Basics*, vol. 34, no. 1, 2021.
- [20] M. Jafari, S. A. Mahmodzade Hoseyni, H. Altenbach, E. Craciun, "Optimum design of infinite perforated orthotropic and isotropic plates," *Mathematics*, vol. 8, no. 4, 2020.