

## Built-in Isolated Level 1 Unidirectional Battery Charger Design Aspects for a Small-Scale Electric Vehicle

Mustafa Yaz<sup>1</sup> and Emrah Cetin<sup>1\*</sup>

0000-0001-7042-7649<sup>1</sup>, 0000-0002-7023-6604<sup>1\*</sup>,

<sup>1</sup> *Electrical and Electronics Engineering Department, Faculty of Engineering and Architecture, Yozgat Bozok University, Yozgat, 66100, Turkey*

### Abstract

Electric vehicles are increasing their place in the market with each passing day. The widespread use of this technology accelerates the development of sub-equipment in electric vehicles. Intensive studies are carried out for the development of many sub-equipment. One of the most important of these is the charging systems of electric vehicles. While electric vehicles are developing, charging systems are also developing rapidly in parallel. In this article, an integrated and isolated unidirectional lithium-ion battery charger design aspects has been implemented for a small-scale electric vehicle in three steps such as simulation, prototype and final product. As a result of the study, the prototype and final products are succeed on a 500 W DC load and the design aspects are demonstrated.

Keywords: Battery charger; Electric vehicle; Isolated charger; Lithium-Ion battery; Unidirectional battery charger.

### Research Article

<https://doi.org/10.30939/ijastech..984760>

Received 19.08.2021  
Revised 04.10.2021  
Accepted 21.11.2021

\* Corresponding author

Emrah Cetin

[emrah.cetin@bozok.edu.tr](mailto:emrah.cetin@bozok.edu.tr)

Address: Electrical and Electronics Engineering Department, Faculty of Engineering, Yozgat Bozok University, Yozgat, Turkey

Tel:+903542178991

### 1. Introduction

The electrification of the automobile industry, come with the range problems due to the battery limitations. The ecosystem of the electric vehicles designed to charge the vehicles inside these ranges. But charging stations are not enough because of the long charging times. If the vehicle is small-scaled, the charging unit better to be built-in.

The battery charger topologies and charging power levels are reviewed in the Yilmaz and Krein. The charging levels are defined as Level 1 (convenience, lower power), Level 2 (primary, middle power), and Level 3 (fast, higher power) power levels [1].

First level chargers can be both unidirectional and bidirectional. If the circuit is operated only in grid to vehicle power flow, the charger is called unidirectional [1-3]. Unidirectional chargers cannot inject energy to the grid. These type of chargers use a diode bridge with and EMI filter at the grid side. Battery side is isolated with a high frequency transformer and dc-dc converter is implemented for limiting cost, volume, losses and weight [4]. Figure 1 illustrates the main power flow directions for the both unidirectional and bidirectional chargers.

A built-in charger of the vehicle gives freedom to EV owners for charging their vehicles wherever a convenient power source is existent. Most of the on-board chargers are inside the limits of the power Level 1 due to the weight, volume, and cost constraints [5, 6].

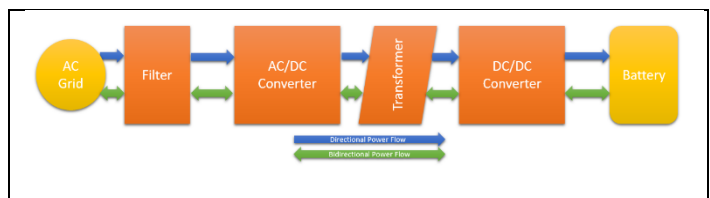

Fig. 1. Unidirectional and bidirectional topologies' power flow.

Nguyen and Lee investigated the multifunctional charger which can charge the batteries both higher and lower voltage levels. They have experimentally studied and showed the effectiveness of the proposed circuit [7].

Soong and Lehn studied to develop an on-board charger that uses the electric vehicle's drivetrain [8]. Researchers are identified and analyzed the common mode leakage current through the filters that are built in electric vehicles [9, 10]. Gao et.al. has made detailed study about the working principles and control of the single-phase integrated on-board charger system [11].

Tuan et al. used soft-switching technique for a unidirectional isolated high-frequency DC-DC converter. The dc conversion ratio and transformer utilization factor are developed by the resonance capacitors parallelly placed to the secondary side diodes [12].

Ghosh et. al. designed a bi-directional on-board charger. This design allows vehicle to grid operation for smart grid applications.

They made a 800 W prototype for this study [13].

M. Hagemeyer et. al. compared the non-isolated unidirectional chargers [14]. M. Y. Metwly et. al. reviewed the on-board charger studies in contrast to motors used in the electric vehicles [15].

J. R. Szymanski focused on fast charging of electric vehicle batteries by using renewable energy sources. They implemented the unidirectional charger in contrast to the grid power quality [16].

U. Morali investigated the open circuit potential of lithium-ion battery pack. He used the taguchi design for this study [17]. Also, Y. E. Ekici and N. Tan researched the different battery types in terms of charging and discharging characteristics [18].

In this paper, an isolated on-board charger design aspect are identified and simulated. After the simulation, the designed circuit is produced and tested. The development and production stages of a level 1 unidirectional lithium-ion battery charger are clearly defined in this study. A prototype board is demonstrated before the final charger board is produced. Section 2 describes the designed circuit, section 3 demonstrates the used topology of the charger, section 4 is about the controller side information of the circuit, section 5 figures the simulation study and section 6 gives the prototype and the tests of the designed system.

## 2. Circuit Design

The built-in charger depends on many factors such as the charge and discharge temperature of a battery, the history of the battery, and the use of the battery. The built-in charging unit, which will be prepared for our vehicle by adhering to the rule book, is one of the most important features of both fast charging of the battery and using it with mains voltage. Our charging unit is designed to have an output power of 500 watts and above in accordance with the rules. Our aim is to design and manufacture the electric vehicle as an isolated system for safe charging of the batteries. The design will consist of 2 parts. These are the power and control part. Isolation in the system will be provided with transformers. In this study, after examining the charging methods of batteries used in electric vehicles, a built-in charging unit will be designed and produced in accordance with this.

MOSFET is preferred as the switching element for current voltage control in the built-in charging unit we will produce. The MOSFET to be used is TO-247 sheath type and the output current is 20 amps at 25 degrees and 13 amps at 100 degrees. The instantaneous pick current value passing over the MOSFET is maximum 62 amps. As in all systems, the efficiency is very important in the built-in charging unit and the internal resistance of the preferred IRFP460N MOSFET is 0.25 ohm. In addition, the maximum voltage between the drain source of the preferred IRFP460N MOSFET is around 500 volts. The temperature-current graph of the MOSFET is given in Figure 2 and the Vgs-Id graph is given in Figure 3.

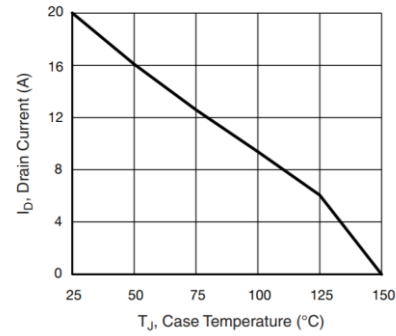

Fig. 2. Temperature-flow graph

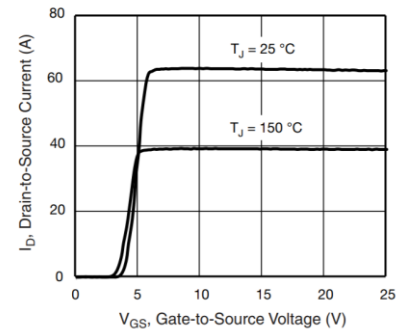

Fig. 3. Vgs-id graph

## 3. Topology

The nominal voltage of our battery pack is 48 volts, and it is 54.6 volts at full charge. In our built-in charging unit, it has been decided to use the full bridge topology, which is generally preferred in systems of level 1 chargers. Full bridge topologies have more components but they have less component stresses [1,19]. In order to obtain 500 watts as output power, at least 10 amps of current must flow through the output of the circuit. The rectification process will be completed by means of bridge diodes of 220 volt AC voltage taken from the mains electricity. Then, the signal will be filtered with the capacitors in the DC busbars and the noise will be minimized. Capacitors will be charged to 300 volts, which is 1.41 times the rms value. With a high frequency watch transformer, around 56 volts will be output. Voltage drop level will be determined in loaded tests and transformer winding will be changed proportionally.

Table 1. Characteristics of the Embedded Charger Unit

Circuit Topology	Full bridge
Power	500w
Output Voltage Range	0-56 volt
Output Current Ripple	0-5 amper
Input Power Factor	0.8
Power Conversion Efficiency	%95
PWM Controller IC	Dspic30f4011
Protection Circuits / Components	Varistör ve akım limitleme
PCB Size	200x200mm

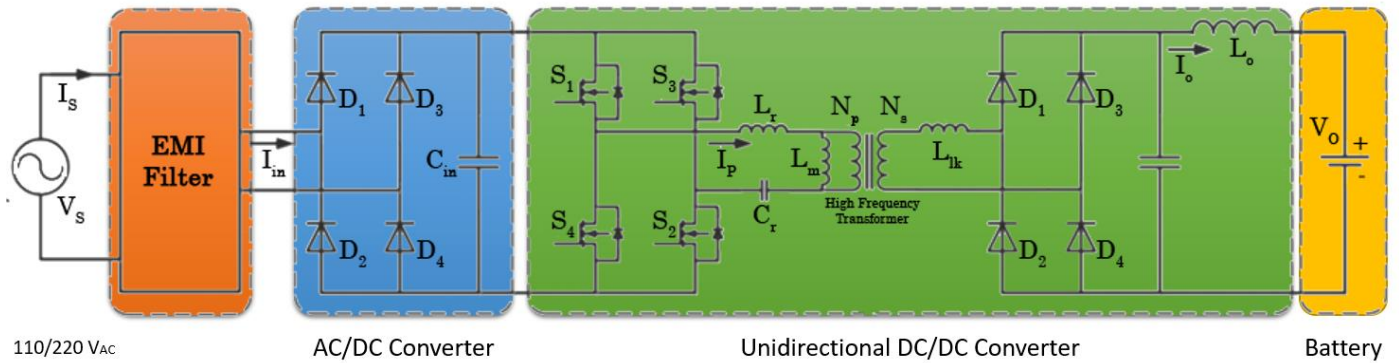

Fig. 4. On-board isolated unidirectional full-bridge charger for Level 1 system

#### 4. Controller

The controller smd case dspic30f4011, which will control the built-in charging unit, has been chosen. The general usage areas of dspic spreader controllers are the power control part. And one of the most important reasons why it is preferred is the presence of complementary PWM outputs. These outputs can operate separately as well as with complementary mode. This feature enables MOSFETs to be switched more easily. It can also be upgraded to 4x, 8x and 16x through external oscillator software. The analog input pins of the processor, which has 30 input output pins, read in 10-bit resolution. The current and voltage values measured by the sensors in the system are read from the analog inputs with a resolution of 10 bits. MOSFETs are switched according to the incoming current and voltage information.

For the AMC1200/B IC, the circuit will be designed in such a way that the regression is separate from the separate current. The purpose here is to control voltage and current during charging. Controls will continue or interrupt the charging status by coding the dspic30f4011 microprocessor by comparing the information coming from the AMC1200/B integrated with the battery information on the output. AMC1200/B will be used to be an isolated system. The purpose of use is an isolated opamp in itself. They have separate 12 Volt and 5 Volt feeds.

A serial Ics25 current sensor is connected to the output terminals of the system. It is transmitted to the other side as a secondary current by reducing the primary current in the circuit at a certain level. The sensor output goes to the controller of the system and the controller calculates the current. When the calculated current reaches undesirable levels, the duty cycle value of the PWM signal is adjusted so that the current is tried to be kept at a constant rate.

Two 220 Volt AC/12 Volt DC isolated transformers will be used to supply the other elements in the system. For 5 Volt supply, it will be provided with the LM7805 IC connected to one of the transformers. The 12-volt DC output will be provided by the 7812 IC and the elements will be fed. In addition, the IR2110 gate drivers will be supplied from the output of the 7815 IC. If the MOSFETs cannot reach full saturation or cut-off, they will heat up more. It is aimed to provide full saturation and full cut-off by giving 15 volts to the gate drivers.

#### 5. Simulation

The built-in charging unit simulation studies were made in the Simulink program, which is an add-on to the MATLAB program. Simulink block structure is given in figure 6.

Input: Diode bridge rectifier 1 rectifying the 220-volt mains voltage as the input data. When the mains voltage is rectified, the DC bus voltage is approximately 312 volts just before the full bridge circuit as seen in figure 5. The DC bus voltage of the full bridge circuit enters the primary side of the transformer. The full bridge structure is simulated as given four 15 kHz driven MOSFETs as given in the figure 6. These MOSFETs' bridge connected to the high frequency transformer for isolating the system.

Output: At the secondary side of transformer, the voltage drops down to the 54.6 volts. The voltage exiting the transformer comes out of the diode bridge rectifier 2 and forms the output voltage.

The simulation results for the output voltage of the built-in charging unit are given in figure 7 that is convenient for the desired battery voltage level 54.6 V. As the result of the simulations, the designed circuit has convenient outputs for the desired charger. Thus, the circuit can be designed by using the simulation parameters.

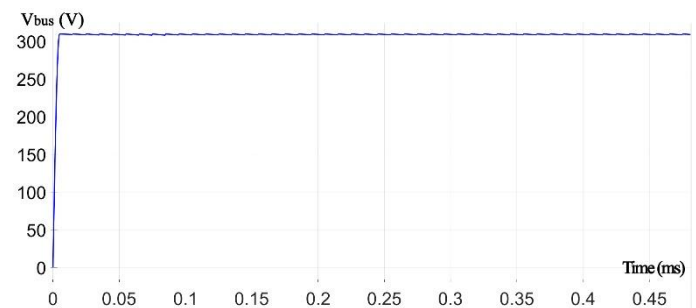

Fig. 5. DC bus voltage output

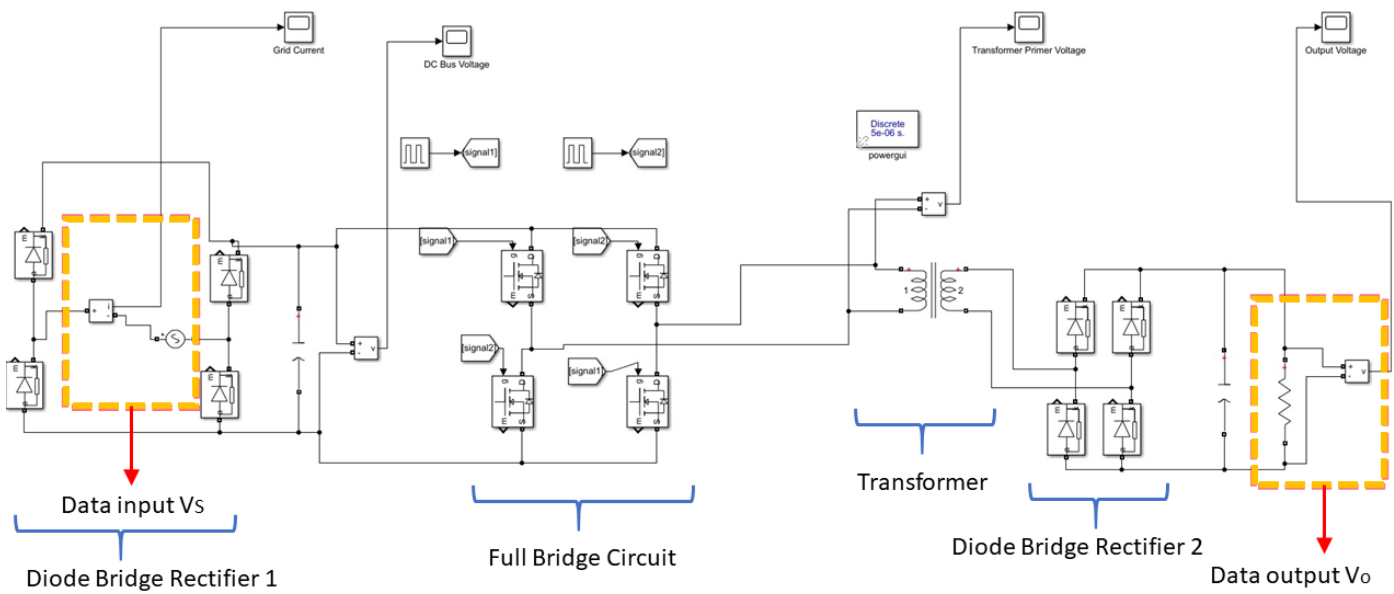

Fig. 6. Simulink circuit diagram

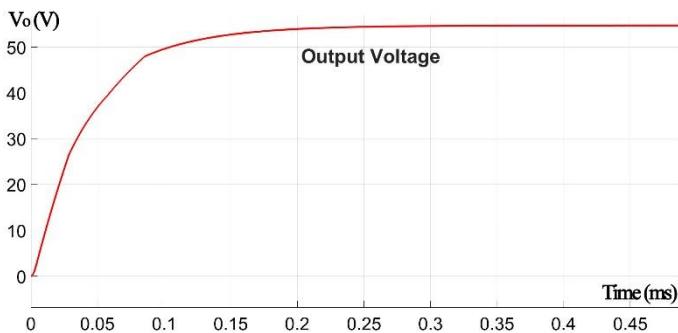

Fig. 7. Output voltage

## 6. Test Results

Before the final circuit, a test design implemented. The control side and the power flow side separated due to the security. Figure 8 illustrates the test run. Test studies of the built-in charging unit were made on the prototype circuit produced. The controller side is separated at the first prototype. The given test platform was established due to test the circuit in load conditions. Also the software algorithm has been tested on the prototype circuit and positive results have been obtained. A constant 54.6 volts was observed as the output voltage. The control algorithm of the built-in charging unit fixes the output current to 9 amps thanks to the full bridge structure, resulting in 500 watts of power.

After getting applicable results from the prototype circuit, the final charger circuit is implemented. Figure 9 shows the resultant circuit. As seen from the illustrated figure, control side is separated by the holes, due to the electromagnetic interference effects. Also the final circuit is tested by the same test bed. The results are taken

like the prototype circuit.

Then, the final circuit is implemented to the small-scale electric vehicle, as seen in the figure 10. The Built-in isolated level 1 uni-directional battery charger is used in this vehicle. The electric vehicle has 2 kWh lithium-ion battery pack with 48 V nominal voltage including 13S lithium-ion battery cells. The characteristics of the battery pack is given in the table 2.

For more lifetime, lithium battery cells should not fall under 3.2 volts. So that, the total battery pack should not fall under 41.6 volts. An experimental study set up for the success of the produced board. When battery pack is 42 volts, charging is started. And each 1 volt charging step is noted. So that, figure 11 is obtained as a result of this test. As seen from the graph, battery pack is got 50 volts in 98 minutes. But full charging time is taken 255 minutes. Furthermore, output current is constant at the 9 amps until the battery reaches to the 50 V. After that the current reduces to the %10 of its constant value until the battery comes to the %100 of its capacity.

This study shows that, lithium-ion battery pack comes quicker to the 50 volts than next 4,6 volts by using developed charger circuit. This test show that, the circuit is succeeded on the battery pack security because of the lithium-ion battery pack characteristics.

Table 2. Characteristics of the battery pack

Each lithium ion battery cell max. voltage	4,2 V
Each lithium ion battery cell max. current	2200 mA
Battery pack parallel cell number	15
Battery pack serial cell number	13
Total battery pack voltage (max)	54,6 V
Total battery pack current (max)	33 A
Nominal battery pack voltage	48 V



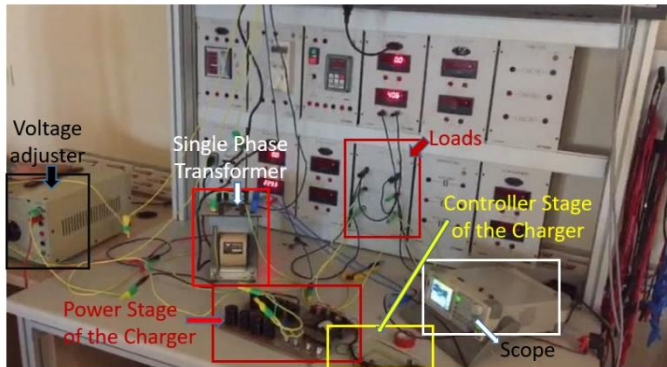

Fig. 8. Circuit test platform

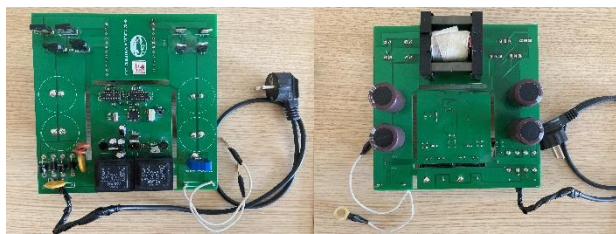

Fig. 9. The final circuit board of the Built-in Isolated Level 1 Unidirectional Battery Charger for a Small-Scale Electric Vehicle with 500W power.



Fig. 10. Small scale test vehicle

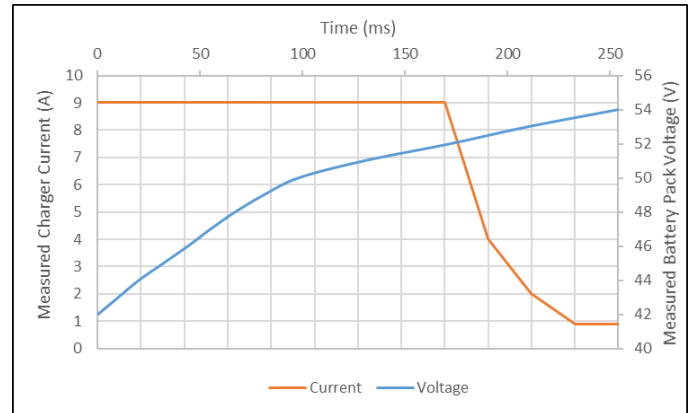

Fig. 11. Measurements of the battery pack voltage and charger current versus time at the output of the produced charger

## 7. Conclusions

Nowadays, the electrification of the mobility is very popular. This study is about the defining the design aspects of an electric vehicle charger. Study is implemented for a small-scale electric vehicle which has 54.6 V battery pack. The charger level is designed as level 1. Charger is isolated by a high frequency transformer. And the unidirectional topology was chosen due to the level 1 characteristics. There are three steps of this study. Firstly, charger topology is simulated. After the simulation results, charger is printed to two separated circuit board as a prototype. The prototype is tested by 500W DC load and worked well. The separation is for security of the control side. Finally, the resultant circuit board is made after the prototype circuit is succeed as given in figure 11. Charger getting slower after the %80 of the charging capacity is observed. This is a security characteristic for the lithium-ion batteries. Constant current is applied to the battery until it's reaching to the 50 V. After that, %10 of the constant current is applied to the full capacity. Thanks to that, battery pack comes faster to the 50 volts than next 4,6 volts by using developed charger circuit. This study shows the design aspects of a battery charger in contrast to small scale electric vehicles. This paper can be a road map to the researchers for designing electric vehicle battery chargers.

## Acknowledgment

This study was supported by TUBITAK/TURKEY in frame of the TUBITAK Efficiency Challenge.

## Conflict of Interest Statement

The authors declare that there is no conflict of interest in the study.

## Credit Author Statement

**Mustafa YAZ:** Practical study and tests.

**Emrah Cetin:** Paper, Study, Conceptualization and Supervision.

## References

- [1] M. Yilmaz and P. T. Krein, "Review of Battery Charger Topologies, Charging Power Levels, and Infrastructure for Plug-In Electric and Hybrid Vehicles," in *IEEE Transactions on Power Electronics*, vol. 28, no. 5, pp. 2151-2169, May 2013, doi: 10.1109/TPEL.2012.2212917.
- [2] A. Sharma and R. Gupta, "PV-Battery Supported Level-1 DC Fast charger for Electric Vehicles," 2019 IEEE Students Conference on Engineering and Systems (SCES), 2019, pp. 1-5, doi: 10.1109/SCES46477.2019.8977218.
- [3] Y. Lee, A. Khaligh and A. Emadi, "Advanced Integrated Bidirectional AC/DC and DC/DC Converter for Plug-In Hybrid Electric Vehicles," in *IEEE Transactions on Vehicular Technology*, vol. 58, no. 8, pp. 3970-3980, Oct. 2009, doi: 10.1109/TVT.2009.2028070.
- [4] B. Singh, B. N. Singh, A. Chandra, K. Al-Haddad, A. Pandey and D. P. Kothari, "A review of three-phase improved power quality AC-DC converters," in *IEEE Transactions on Industrial Electronics*, vol. 51, no. 3, pp. 641-660, June 2004, doi: 10.1109/TIE.2004.825341.
- [5] S. Haghbin et al., "Integrated chargers for EV's and PHEV's: examples and new solutions," *The XIX International Conference on Electrical Machines - ICEM 2010*, 2010, pp. 1-6, doi: 10.1109/ICELMACH.2010.5608152.
- [6] M. Grenier, M. G. Hosseini Aghdam and T. Thiringer, "Design of on-board charger for plug-in hybrid electric vehicle," 5th IET International Conference on Power Electronics, Machines and Drives (PEMD 2010), 2010, pp. 1-6, doi: 10.1049/cp.2010.0101.
- [7] H. V. Nguyen and D. Lee, "Single-phase multifunctional onboard battery chargers with active power decoupling capability," 2018 IEEE Applied Power Electronics Conference and Exposition (APEC), 2018, pp. 3434-3439, doi: 10.1109/APEC.2018.8341597.
- [8] T. Soong and P. W. Lehn, "On-board Single-Phase Electric Vehicle Charger with Active Front End," 2018 International Power Electronics Conference (IPEC-Niigata 2018 -ECCE Asia), 2018, pp. 3203-3208, doi: 10.23919/IPEC.2018.8507547.
- [9] Y. Zhang et al., "Leakage Current Issue of Non-Isolated Integrated Chargers for Electric Vehicles," 2018 IEEE Energy Conversion Congress and Exposition (ECCE), 2018, pp. 1221-1227, doi: 10.1109/ECCE.2018.8558133.
- [10] H. V. Nguyen and D. Lee, "Advanced Single-Phase Onboard Chargers with Small DC-Link Capacitors," 2018 IEEE International Power Electronics and Application Conference and Exposition (PEAC), 2018, pp. 1-6, doi: 10.1109/PEAC.2018.8590400.
- [11] J. Gao, W. Sun, D. Jiang, Y. Zhang and R. Qu, "Improved Operation and Control of Single-Phase Integrated On-Board Charger System," in *IEEE Transactions on Power Electronics*, vol. 36, no. 4, pp. 4752-4765, April 2021, doi: 10.1109/TPEL.2020.3025664.
- [12] C. A. Tuan, H. Naoki and T. Takeshita, "Unidirectional Isolated High-Frequency-Link DC-DC Converter Using Soft-Switching Technique," 2019 IEEE 4th International Future Energy Electronics Conference (IFEEC), 2019, pp. 1-7, doi: 10.1109/IFEEC47410.2019.9015117.
- [13] A. Ghosh, C. N. Man Ho and K. K. Man Siu, "A Manitoba Converter based Bi-directional On-board charger for Plug-in Electric Vehicles," 2020 IEEE Energy Conversion Congress and Exposition (ECCE), 2020, pp. 1654-1660, doi: 10.1109/ECCE44975.2020.9235606.
- [14] M. Hagemeyer, P. Wallmeier, F. Schafmeister and J. Böcker, "Comparison of Unidirectional Three- and Four-Wire-Based Boost PFC-Rectifier Topologies for Non-Isolated Three-Phase EV On-Board Chargers Under Common-Mode Aspects," 2021 IEEE Applied Power Electronics Conference and Exposition (APEC), 2021, pp. 569-576, doi: 10.1109/APEC42165.2021.9487036.
- [15] M. Y. Metwly, M. S. Abdel-Majeed, A. S. Abdel-Khalik, R. A. Hamdy, M. S. Hamad and S. Ahmed, "A Review of Integrated On-Board EV Battery Chargers: Advanced Topologies, Recent Developments and Optimal Selection of FSCW Slot/Pole Combination," in *IEEE Access*, vol. 8, pp. 85216-85242, 2020, doi: 10.1109/ACCESS.2020.2992741.
- [16] Szymanski, J.R.; Zurek-Mortka, M.; Wojciechowski, D.; Poliakov, N. Unidirectional DC/DC Converter with Voltage Inverter for Fast Charging of Electric Vehicle Batteries. *Energies* 2020, 13, 4791. <https://doi.org/10.3390/en13184791>
- [17] Morali "Investigation of Open Circuit Potential of Lithium-Ion Battery by The Taguchi Design" *International Journal of Automotive Science and Technology* 5 (2): 126-130, 2021, doi:10.30939/ija-stech.868549
- [18] Ekici and Tan "Charge and discharge characteristics of different types of batteries on a hybrid electric vehicle model and selection of suitable battery type for electric vehicles" *International Journal of Automotive Science and Technology* 3 (4): 62-70, 2017, doi:10.30939/ijastech..527971
- [19] M. Pahlevaninezhad, P. Das, J. Drobniak, P. K. Jain and A. Bakhshai, "A Novel ZVZCS Full-Bridge DC/DC Converter Used for Electric Vehicles," in *IEEE Transactions on Power Electronics*, vol. 27, no. 6, pp. 2752-2769, June 2012, doi: 10.1109/TPEL.2011.2178103.