



Research Article

Simulation-Optimization Modelling of Yield and Yield Components of Tomato Crop

Nura Jafar SHANONO^{a*}, Lawal AHMAD^b, Nuraddeen Mukhtar NASIDI^a,
Abdul'aziz Nuhu JIBRIL^a, Mukhtar Nuhu YAHYA^a

^a. Department of Agricultural and Environmental Engineering, Bayero University Kano, NIGERIA

^b Department of Agricultural and Bioenvironmental Engineering, Waziri Umaru Federal Polytechnic, Birnin-Kebbi, NIGERIA

(*): Corresponding Author: njshanono.age@buk.edu.ng

Received: 16.04.2023

Article Info
Accepted: 14.06.2023

Published: 30.06.2023

ABSTRACT

This study simulate and optimize the yield and yield parameters of tomato using AquaCrop model and genetic algorithm (GA) respectively. The AquaCrop model was firstly calibrated using the data obtained from the field and was later used to simulate the observed yield, water productivity and biomass of tomato. The Root Mean Square Error (RMSE), Coefficient of Residual Mass (CRM) Normalized Root Mean Square Error (NRMSE) and Modelling efficiency (EF) were used to compare the observed and simulated values. The governing equation of AquaCrop simulation software was then optimized using the evolutionary optimization method of GA with MATLAB programming software. All the statistical indices except CRM used in comparing the simulated and observed values indicated good agreement. The CRM values of -0.11, -0.06 and -0.20 were obtained for the yield, biomass and water productivity of tomato which indicated a very slight over-estimation of the observed results by the AquaCrop model. The optimization algorithm terminated when the optimal values of yield and biomass were 4.496 ton ha⁻¹ and 4.90 ton ha⁻¹ respectively. The GA revealed that the yield and biomass of tomato can be increased by 57% and 23% respectively if the optimized parameters were either attained on the field experiment or used during simulation. Thus, the study ascertained that crop simulation models such as AquaCrop and optimization algorithms can be used to identify optimal parameters that if maintained on the field could improve the yield of crops such as tomato.

Keywords: AquaCrop model, Drip irrigation, Genetic algorithm, Optimization, Simulation, Tomato yield

To cite: Shanono NJ, Ahmad L, Nasidi NM, Jibril AN and Yahya MN (2023). Simulation-Optimization Modelling of Yield and Yield Components of Tomato Crop. *Turkish Journal of Agricultural Engineering Research (TURKAGER)*, 4(1), 104-124. <https://doi.org/10.46592/turkager.1283793>



INTRODUCTION

Sustainable agricultural production of food with the aim to meet the ever-increasing population could be achieved when more food is produced with less water. This can be realized through an optimal irrigation water management ([Shanono *et al.*, 2022](#)). In irrigation practice, crop models are important tools developed to improve the efficiency of irrigation systems through water saving and improved water delivery, reduce the operating and labour costs and ensure sustainable agricultural production that will enhance the food security and socio-economic status of the farmers and nation ([Shanono *et al.*, 2014](#); [Perea *et al.*, 2017](#)). These models simulate the physiological processes of a given crop growth parameter, and matter and water transport, predict yield, and yield components (leaves, roots, and stems) of crop ([Seidel, 2012](#)).

Different crop simulation models have been developed some decades ago coupled with the advances achieved in crop sciences and computing technologies to improve crop productivity ([Shanono, 2019](#); [Reynolds *et al.*, 2018](#); [Singels *et al.*, 2013](#)). Some of these crops simulation models include the soil vegetation–atmosphere transfer (SVAT) model, AquaCrop model, decision support systems for agrotechnology transfer (DSSAT), the agricultural production systems simulator (APSIM), and Environmental Policy Integrated Climate model (EPIC). These crop simulation models offer the opportunity to investigate the effects of cultivar potential for new areas, droughts and other factors affecting the yield and crop production which will save the energy, water, time and other resources required for experiments ([Kephe *et al.*, 2021](#); [Kloss *et al.*, 2014](#); [Shanono *et al.*, 2012](#)). DSSAT is one of the irrigation simulation models developed to enhance crop water use efficiency. The use of DSSAT in agriculture has increased across the world during the last three decades. The DSSAT has been applied for balancing the water allocation for irrigation and in minimizing pollution while adding value to nutrient-use efficiency ([Ara *et al.*, 2021](#)).

[Ko *et al.*, \(2009\)](#) applied EPIC simulation model in Texas to assess the effect of water consumption variables including crop evapotranspiration (ET_c) and crop water-use efficiency (WUE) on the yield of maize and cotton. The EPIC was applied to simulate the response of crop yield to various irrigation levels and the results prove EPIC to be a remarkable decision support tool. [Walser *et al.*, \(2011\)](#) used Soil–Vegetation–Atmosphere Transfer (SVAT) models were used to simulate a rain-out experimental field of wheat and barley to maximize water productivity. The SVAT performed remarkably well to a slightly water-stressed crop. The AquaCrop model stands to be the most popularly known and widely used crop simulation model due to its ease of operation, and high accuracy ([Raes *et al.*, 2022](#)). AquaCrop incorporates the effects of various crop production factors including water-stress, salinity, climate, field management and does not consider nutrients cycle or balances to determine soil fertility stress but its expected effects on crop biomass production ([Gaelen *et al.*, 2015](#)). AquaCrop has been used widely by different researchers under different climatic and soil conditions and has been confirmed to accurately simulate plant yield, biomass and water productivity ([Bitri *et al.*, 2014](#)).

In addition, optimization algorithms are also effective tools for solving problems of irrigation water management ([Jiang *et al.*, 2016](#)). The optimization tool describes

and generalizes the irrigation process using a series of mathematical expressions and optimization algorithms to obtain the best results ([Li *et al.*, 2020](#); [Singh, 2012](#)). According to [Seidel \(2012\)](#), efficient irrigation water management can further be sustained by optimizing the operational parameters such as irrigation threshold and amount of irrigation water. Water-sharing or scheduling optimization models have been developed, using optimization techniques such as genetic algorithms, and dynamic, linear and non-linear programming ([Li *et al.*, 2020](#)). Optimization can change conventional irrigation systems to optimal ones while maintaining high crop yields and ensuring little or no water is lost by deep percolation. Genetic algorithms (GA) is a popular optimization tool used for searching optimum decision results thereby solving diverse challenges that relate to the planning, design and management of resources ([Whitley, 2001](#)). GA is a form of Evolutionary algorithm (EA) that is a well-known device for the effective optimization of irrigation water. Evolutionary algorithms search for the optimum results from the population in parallel but not from a single point ([Ikudayisi and Adeyemo, 2015](#)).

An improved irrigation system that will minimise the inputs while maximizing the output can be best achieved by linking simulation models with optimization algorithms thereby searching optimal results. Studies related to the development and usage of the simulation-optimization approach to the management of drip irrigation are still few ([Akbari *et al.*, 2018](#); [McCarthy *et al.*, 2013](#)). Most of the experiments carried out to improve water productivity in irrigation systems focused on either simulating or optimizing the system separately but rarely integrate simulation with optimization modelling for crop and water productivity. To this end, this study intends to employ a simulation-optimisation approach to simulate and optimize yield and yield components of tomato for optimum production. Such a study is particularly important for addressing water scarcity in the semi-arid area of northwestern Nigeria which occasionally experiences climatic uncertainties such as drought and erratic rainfall.

MATERIALS and METHODS

Study Location and Experimental Set-up

Study location

This study was conducted at the training farm of the Department of Agricultural and Environmental Engineering, Bayero University, Kano. Kano is located in the northwestern part of Nigeria and lies between latitude 12° 0' 0.0000" N and longitude 8° 31' 0.0012" E and it is 472.45 m amsl. Kano is situated in a semi-arid zone with an average yearly rainfall of 898 mm which is below the average evaporation of 1560 mm. The average maximum and minimum temperatures are 32°C and 26°C respectively ([Ahmad and Haie, 2018](#); [Lawal and Shanono, 2022](#)).

Experimental set-up

The field study was carried out from 24th February to 31st May 2022 on a 3 m × 15 m experimental plot which was divided into two units (UA and UB). The drip system is a gravity-driven irrigation method which consists of 2000 litres (2 m³) tank capacity mounted 2 m above the ground connected to the main pipeline which was also connected to the submarine pipeline. The submarine pipeline has 20 junctions and

each junction was connected to a lateral, and the laterals were spaced at 0.75 m apart as recommended row spacing of the tomato crop. Each lateral has a length of 3 m and 9 emitters that are spaced 0.3 m apart based on the recommended crop spacing of the tomato crop. Figure 1 shows the schematic of the experimental plot.

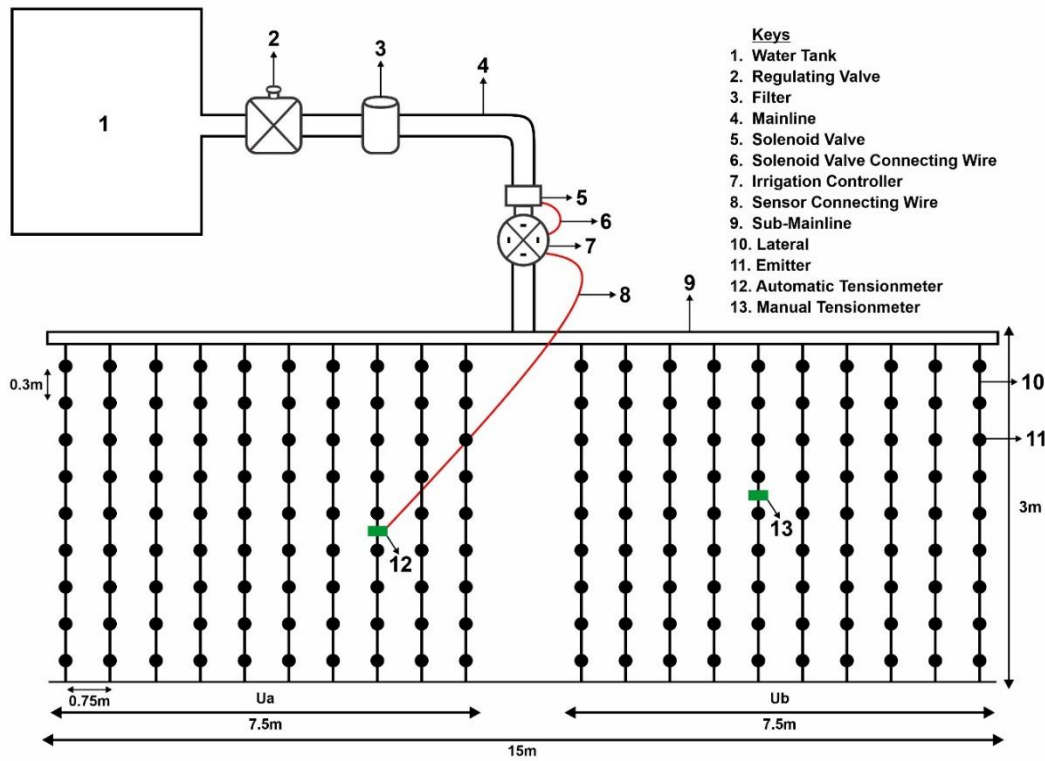

Figure 1. The layout of the experimental plot.

Soil Analysis of the Experimental Site

The soil analyses of the experimental field show that the soil has a textural class of sandy loam (82.4% sand, 4% silt and 13.76% clay) and an average bulk density of 1.65 g cm^{-3} . The average soil moisture at saturation, field capacity and the permanent wilting point was found to be 30.09%, 17.77% and 7.48% respectively. The NPK: 15-15-15 fertilizer was applied at the rate of 250 kg ha^{-1} as recommended by [Isah et al. \(2014\)](#). The pesticide and fungicide chemicals were applied based on the advice of the experts in the study area. The weeding was also conducted based on the advice of the experienced local farmers in the study area. All other standard agronomic procedures were strictly followed.

Soil Water Retention Curve for the Experimental Sites

The automatic tensiometer was installed in the experimental plot at a depth of 15 cm and set at -15 kPa and -10 kPa as the lower and upper soil moisture limits respectively for sandy loam soils ([Thompson and Gallardo, 2005](#)). The automatic tensiometer was connected to an irrigation controller that is also connected to the solenoid valve which was installed at the mainline of the experimental field. The manual tensiometer was also installed at depth of 15 cm in the field to serve as a control. Both automatic and manual tensiometers were calibrated by determining the soil moisture using a gravimetric method of the sample taken at the exact depth

of the ceramic tips of the sensors and the results were related to the soil-water characteristic curve of the experimental site. The soil moisture characteristic curve of the experimental site is shown in Figure 2.

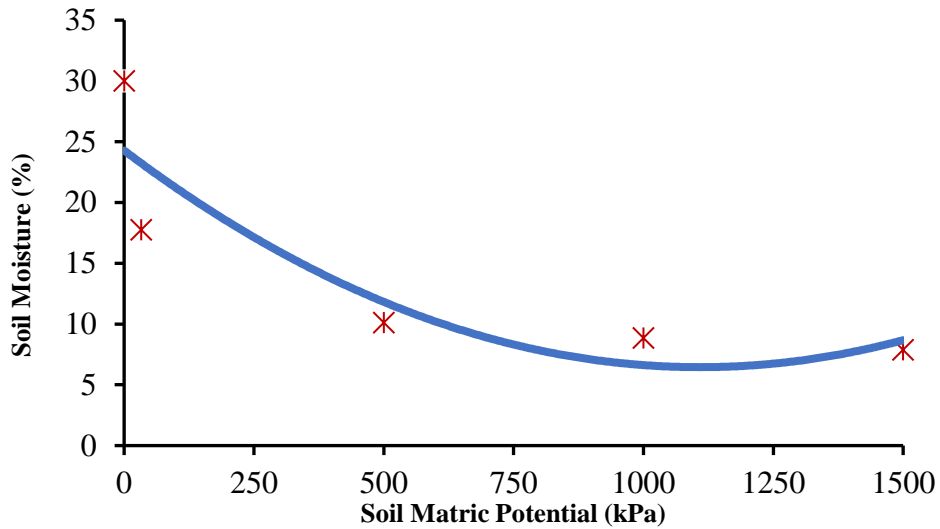

Figure 2. Soil water retention curves of the experimental site.

The automatic tensiometer signals the irrigation controller to trigger or interrupt/stop irrigation events based on the set limits and the controller will either open or close the solenoid valve to initiate or suspend the irrigation events. Figure 3, 4, 5 and 6 show the automatic sensor, irrigation controller, solenoid valve and manual tensiometer installed in the experimental plot.



Figure 3. Automatic tensiometer.



Figure 4. Irrigation controller.



Figure 5. Solenoid valve



Figure 6. Manual tensiometer

Yield Measured in the Experimental Site

The yield from the experimental plot (Y_e) was measured in both its fresh and dry state. The fresh yield was determined by weighing all the harvested tomato using a weighing scale and divided by the experimental field area (kg m^{-2} or ton ha^{-1}). Measurement of dry yields and aboveground biomass were carried out from the plants selected from four laterals of each unit. In each of the selected laterals, three plants were randomly selected and their yields and aboveground biomass were oven-dried at 70°C for 24 hours. The water productivity (WP_e) was computed as the ratio of yield (ton ha^{-1}) to the amount of water applied (m^3).

Simulation of Yield and Yield Components of Tomato using AquaCrop

The AquaCrop

The AquaCrop simulation model was used for the simulation. The model estimates crop yield, crop water requirement, and crop water use efficiency (WUE) in water-stressed conditions. It has also been used under supplementary irrigation and rainfed farming ([Heng *et al.*, 2009](#); [Hadebe *et al.*, 2017](#)).

Calibration of the AquaCrop Model

The AquaCrop model was calibration to account for adjustment of the local varieties or local environmental and management conditions. The parameters for AquaCrop calibrations were divided into two and include crop parameters and non-conservative parameters. The conservative crop parameters include crop growth, transpiration, yield formation, water stresses, biomass and temperature stress. Generally and in principle, the conservative variables do not require adjustment to the local situations and can be used in simulations ([Steduto *et al.*, 2012](#)).

The FAO has calibrated crop parameters for several crops including tomato which is the test crop for this study. In this study, the crop variables used in calibrating the AquaCrop are summarized in Table 1 and they include transplanting, emergence, flowering and maturity dates, initial canopy and maximum canopy cover, harvested index, plant density and the effective rooting depth of the plants. The meteorological data that include the wind speed, rainfall, solar radiation and minimum and maximum temperature were obtained from the Centre for Dryland Agriculture, Bayero University, Kano which is in proximity to the study area.

Table 1. Field parameters for calibration of AquaCrop model.

| S/No. | Parameter | Value |
|-------|--|---------------------------------|
| 1 | Transplanting | 24 th February, 2022 |
| 2 | Emergence | 3 rd March, 2022 |
| 3 | Maximum Canopy cover | 25 th April, 2022 |
| 4 | Maturity | 10 th May, 2022 |
| 5 | Flowering | 5 th April, 2022 |
| 6 | Time to start of canopy senescence | 7 th May, 2022 |
| 7 | End of flowering | 11 th May, 2022 |
| 8 | Maximum Canopy cover | 0.80 |
| 9 | Harvested Index, HI | 51.40 % |
| 10 | Initial Canopy cover | 0.25% |
| 11 | Plant density (plant m ⁻²) | 4 plant m ⁻² |
| 12 | Effective rooting depth (mm) | 0.6 m |

Field and Climatic Data for Simulation

The input parameters used in simulating the yield, water productivity and biomass of tomato in the AquaCrop model are shown in Table 2 and they include soil parameters, crop parameters, amount of irrigation water applied and climatic data. All the input parameters except climatic data were obtained from the study area while the climatic data which include the rainfall, wind speed, maximum and minimum temperature and solar radiation were obtained from the Centre for Dryland Agriculture, Bayero University, Kano which is in proximity to the study.

Table 2. The AquaCrop model input data.

| S/No. | Parameters | Value |
|-------|---|--|
| 1 | Saturated hydraulic conductivity, K_{sat} (mm h ⁻¹) | 41.5 mm h ⁻¹ |
| 2 | Saturation (%) | 30.09 % |
| 3 | Field capacity, FC (%) | 17.77 % |
| 4 | Permanent wilting point, PWP (%) | 7.48 % |
| 5 | Soil texture | Sandy loam (82.4% sand, 4% silt and 13.76% clay) |
| 6 | Plant density (plant m ⁻²) | 4 plant m ⁻² |
| 7 | Harvest index | 50.20 % |
| 8 | Effective rooting depth (mm) | 0.6 m |
| 9 | Flowering time (days) | 40 days |
| 10 | Maturity time (days) | 75 days |
| 11 | Irrigation method | Drip |
| 12 | Amount of irrigation water applied (m ³) | 20.847 m ³ |

Comparison Between the Observed and Simulated Tomato Yield and Yield Component

The comparison between experimental (observed - O) and simulated (predicted - P) results of the yield and yield components of tomato were carried out using four statistical indices;

i) The Root Mean Square Error (RMSE)

This is to measure the precision of the outcomes. If RMSE tends towards 0, the measure of precision between the predicted and measured values increase.

$$RMSR = \left[\frac{1}{n} \sum_{i=1}^n (P_i - O_i)^2 \right]^{0.5} \quad (1)$$

Where P_i = simulated value, O_i = observed value, n = number of the observation.

ii) Normalized Root Mean Square Error (NRMSE)

This is a statistical index that facilitates the comparison between the models of different scales. The NRMSE classified the comparison into excellent, good, acceptable and poor based NRMSE percentage. The value of $NRMSE < 10\%$ is termed as Excellent, $NRMSE 10\%$ to 20% is Good, $NRMSE 20\%$ to 30% , is Acceptable and $NRMSE > 30\%$ is poor. Equation 2 shows the formula for computing NRMSE.

$$NRMSE = 100 \times \frac{\sqrt{\left[\frac{1}{n} \sum_{i=1}^n (P_i - O_i)^2 \right]}}{O_m} \quad (2)$$

Where P_i = simulated value, O_i = observed value and O_m = mean of the observed values.

iii) Modelling Efficiency (EF)

This is also known as the Coefficient of Nash-Sutcliffe (Nash and Sutcliffe, 1970), which is used to measure the fitness between the measured and predicted values and it ranges from $-\infty$ to 1. When EF is 0 shows results are as good as the mean value of the measured data, while an EF of less than 0, implies that the measured value is better than the simulated. But when EF is 1 indicates a perfect match of the predicted to the measured data.

$$EF = 1 - \frac{\sum_{i=1}^n (O_i - P_i)^2}{\sum_{i=1}^n (O_i - O_m)^2} \quad (3)$$

iv) Coefficient of Residual Mass (CRM)

This is the measure if the model under or over-predict measured values. A given value of zero (0) shows a perfect model, a negative value reveals overestimation whereas a positive value indicates underestimation.

$$CRM = \frac{\sum_{i=1}^n O_i - \sum_{i=1}^n P_i}{\sum_{i=1}^n O_i} \quad (4)$$

Where; O_i = observed value, P_i = model predicted value, O_m = mean of measured values and n = number of data.

Optimization of the Simulated Parameters using Genetic Algorithm

The dry yield, aboveground biomass and crop water productivity of tomato crops were simulated using AquaCrop model. The simulated AquaCrop model was then optimized using the evolutionary optimization method of genetic algorithm (GA). The general procedures for solving any optimization problem using genetic algorithms include the initialization process, mutation, crossover and selection.

Firstly, populations of individuals as potential solutions are randomly generated. Fitness function is used to assess each generated solution. During each iteration process, a selection process is then applied to generate a new population which is more optimum compared to the previous population. The solutions will then pass through mutation and crossover and this is to mimic the natural evolution process. Such a process of iteration will continue until a stoppage criterion is reached (Eiben and Smith, 2015). The Operational framework of the genetic algorithm is summarised in Figure 7.

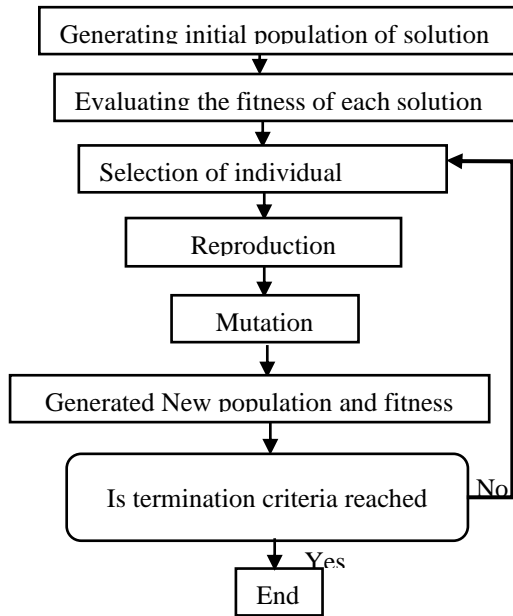

Figure 7. Operational framework of genetic algorithm.

The operational principle of the coupled simulation-optimization model of tomato production under a sensor-based drip irrigation system via genetic algorithm is shown in Figure 8.

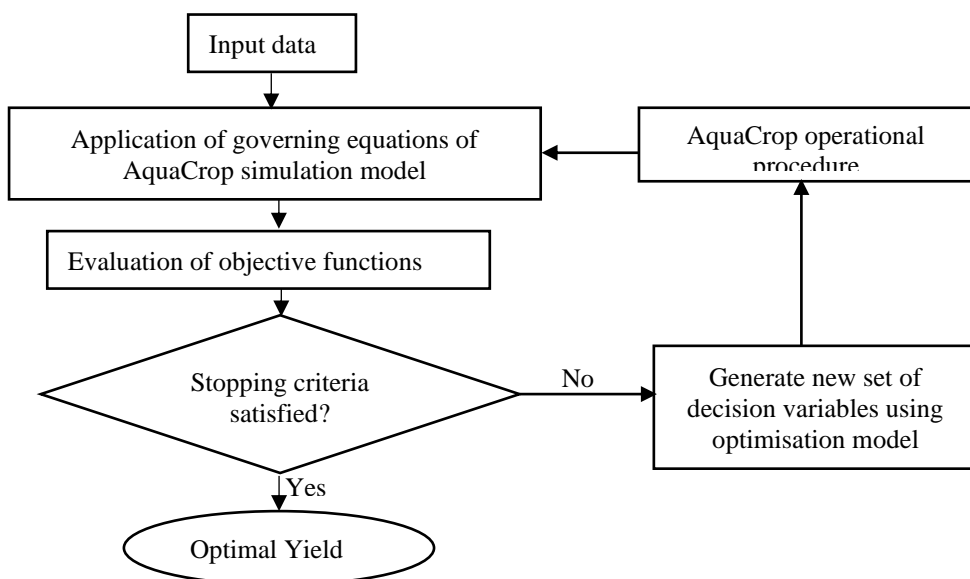

Figure 8. Operational framework of the simulation-optimization model via AquaCrop-Genetic Algorithm.

The parameterizations and ranges of the parameters affecting the model are shown in Table 3 below.

Table 3. Optimization parameters and ranges.

| S/No. | Parameter | Symbol | Ranges |
|-------|------------------------------------|--------------|--|
| 1 | Soil fertility stress | $K_{S_{wp}}$ | 0 - 1 |
| 2 | Yield | Y_{expt} | 3000 - 200000 kg ha ⁻¹ |
| 3 | Crop transpiration | ET | 4000 - 8000 m ³ ha ⁻¹ season ⁻¹ |
| 4 | Daily transpiration | Tr_i | 4.0 - 8.0 mm day ⁻¹ |
| 5 | Daily reference evapotranspiration | ET_{oi} | 4.0 - 9.0 mm day ⁻¹ |
| 6 | Total Fresh plant weight | $TFPW$ | 1.28 - 29.8 ton ha ⁻¹ |
| 7 | Marketable yield | MY | 2.7 - 18 ton ha ⁻¹ |
| 8 | Non-marketable yield | NMY | 0 - 2.7 ton ha ⁻¹ |

The objective function of the optimization is the governing equation of the AquaCrop simulation model is stated in Equation 5.

$$\text{Maximise, } Y = K_{S_{wp}} \frac{Y(expt)}{ET} \sum \left(\frac{Tr_i}{ET_{oi}} \right) \times \frac{MY}{FPW+MY+NMY} \quad (5)$$

Where; Y = optimised yield (ton ha⁻¹), MY = marketable yield, FPW = fresh plant weight, NMY = non-marketable yield, $K_{S_{wp}}$ = coefficient of soil fertility stress, $Y(expt)$ = expected yield.

RESULTS AND DISCUSSION

Dry Yield, Water Productivity and Dry Biomass of Tomato from AquaCrop

Simulated yield, and yield components of tomato

Table 4 shows the simulated dry yield, water productivity and dry biomass of tomato using the AquaCrop model. The AquaCrop simulation results show an average dry yield of 2.10 and 1.76 ton ha⁻¹ for units A and B respectively. The average value of the yield for the whole experiment is 1.93 ton ha⁻¹. The values of the simulated dry biomass for units A and B are 3.65 and 4.00 ton ha⁻¹ averaging 3.83 ton ha⁻¹ for the study. The water productivity obtained from the simulation is 0.7 and 0.5 kg m⁻³ for units A and B respectively. The average value of water productivity of the simulated result is 0.60 kg m⁻³.

Table 4. Simulated yield, water productivity and dry biomass of tomato.

| Unit | Dry Yield (ton ha ⁻¹) | Water Productivity (kg m ⁻³) | Dry Biomass (ton ha ⁻¹) |
|---------|-----------------------------------|--|-------------------------------------|
| Unit A | 2.10 | 0.70 | 3.65 |
| Unit B | 1.76 | 0.50 | 4.00 |
| Average | 1.93 | 0.60 | 3.83 |

Observed Dry Yield, Dry Biomass and Water Productivity of Tomato

Table 5 shows the observed dry yield, dry biomass and water productivity of tomato from the field. The average observed dry yields for units A and B are 1.95 and

1.52 ton ha⁻¹ respectively. The average value of the observed dry yield for the whole experiment is 1.74 ton ha⁻¹. The values of observed dry biomass for units A and B are 3.40 and 3.85 ton ha⁻¹ averaging 3.63 ton ha⁻¹ for the study. The water productivity obtained from the simulation is 0.65 and 0.35 kg m⁻³ for units A and B respectively. The average value of water productivity of the observed dry yield is 0.50 kg m⁻³.

Table 5. Observed dry yield, water productivity and dry biomass of tomato.

| Unit | Observed dry yield (ton ha ⁻¹) | Observed water productivity (kg m ⁻³) | Observed dry biomass (ton ha ⁻¹) |
|---------|---|--|---|
| Unit A | 1.95 | 0.65 | 3.40 |
| Unit B | 1.52 | 0.35 | 3.85 |
| Average | 1.74 | 0.50 | 3.63 |

Simulated and Observed Dry Yield, Water Productivity and Biomass of Tomato

Simulated and observed dry yield of tomato

Figure 9 showed the simulated and observed dry yield of tomato. The figure represents the average yield of the simulated and observed values for units A and B and the average yield of the observed and simulated value for the whole study. The values of the average simulated dry yield for units A and B are 2.10 and 1.76 ton ha⁻¹ respectively. The average dry simulated yield for the study is 1.93 ton ha⁻¹. The average observed dry yield for units A and B are 1.95 and 1.52 ton ha⁻¹ averaging 1.74 ton ha⁻¹ for the whole experiment.

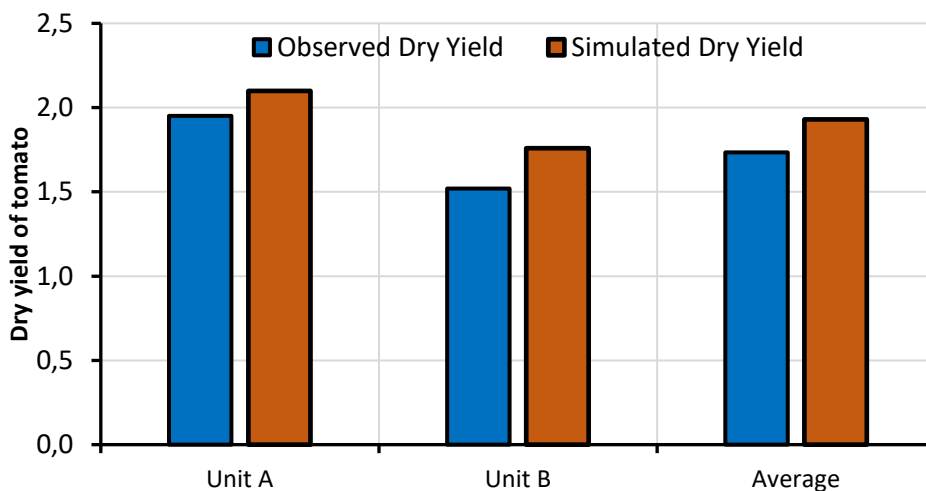

Figure 9. Simulated and observed dry yield of tomato.

Simulated and observed water productivity of tomato

Figure 10 showed the simulated and observed water productivity of tomato. The figure represents the average values of the observed and simulated water productivity of tomato for units A and B and the average simulated and observed water productivity for the whole study. The average simulated water productivity for units A and B are 0.7 and 0.5 kg m⁻³ respectively. The average simulated water productivity for the study is 0.6 kg m⁻³. The average observed water productivity for unit A and B are 0.65 and 0.35 kg m⁻³ respectively. The average observed water productivity for the whole experiment is 0.5 kg m⁻³.

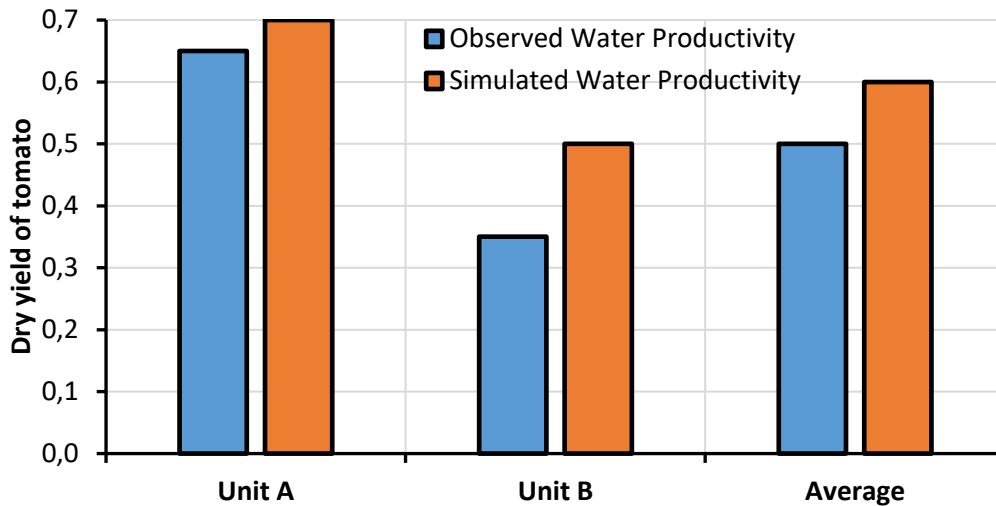

Figure 10. Observed and simulated water productivity of tomato.

Simulated and observed dry biomass of tomato

Figure 11 showed the simulated and observed biomass. The figure represents the average dry observed and simulated biomass of tomato for units A and B and the average biomass of the simulated and observed value for the whole study. The averages simulated dry biomass for units A and B are 3.65 and 4.00 ton ha⁻¹, respectively. The average dry simulated aboveground biomass for the whole study is 3.83 ton ha⁻¹. The average observed dry biomass for units A and B are 3.4 and 3.85 ton ha⁻¹ respectively. The average observed dry biomass for the whole experiment is 3.63 ton ha⁻¹.

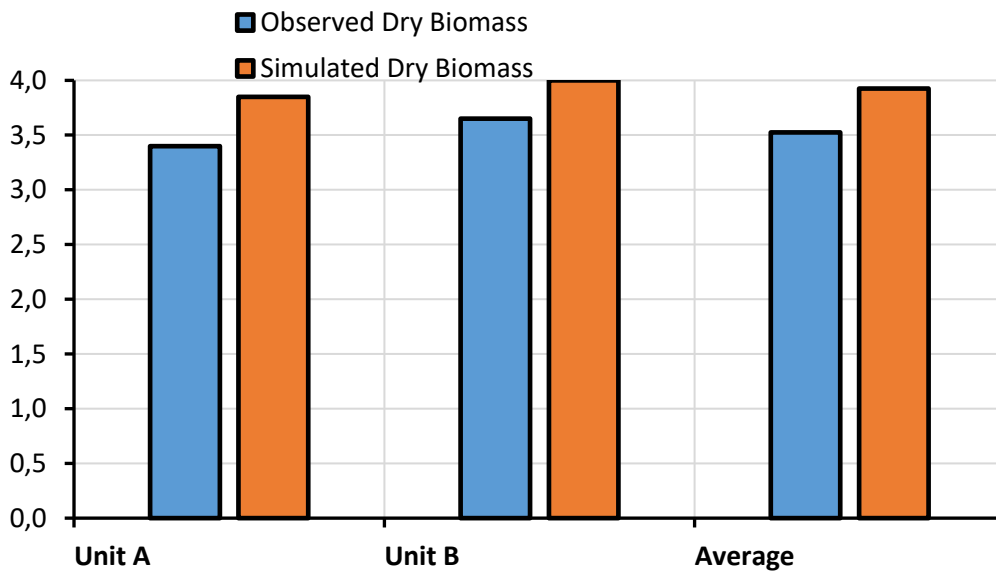

Figure 11. Observed and simulated dry biomass of tomato.

Statistical Comparison Between Simulated and Observed Results

The observed and simulated results were subjected to comparison using four statistical indices to determine the accuracy of AquaCrop simulation model.

Comparing Observed and Simulated Dry Yield of Tomato

The results of statistical indices (RMSE=0.2, EF= 0.13, CRM=-0.11, NRMSE=11%) used in comparing the simulated and observed dry yields of tomato revealed good agreement between the observed and simulated values. The value of the normalized root means square error, NRMSE of 11% is classified as good (10 to 20%) and is similar to what has been established by [Takács *et al.* \(2021\)](#) who obtained an NRMSE value of 13.6% for comparing the observed-field and AquaCrop simulated yields of tomato. The value of NRMSE of 11% obtained for the comparison contradicts the works of [Vegu *et al.* \(2018\)](#); [Hendy *et al.* \(2019\)](#); [Thangaraju \(2020\)](#); [Farrokhi *et al.* \(2021\)](#) and [Ebrahimipak *et al.* \(2022\)](#), whose when compared between the AquaCrop simulated and the observed yield of tomato recorded an excellent value of NRMSE (< 10%) of 3.1%, 9.5%, 3.76 %, 9.97% and 0.07%, respectively.

The value of the root means square error, RMSE of 0.20 obtained for the comparison is similar to the works of [Sang \(2020\)](#); [Thangaraju \(2020\)](#); [Cheng *et al.* \(2022\)](#); [Muroyiwa *et al.* \(2022\)](#); [Ebrahimipak *et al.* \(2022\)](#) who used AquaCrop to simulate tomato yield and obtained RMSE values of 0.13, 0.40, 0.34, 0.34, and 0.42 respectively for comparison between the observed and simulated yields. This revealed a strong relationship between simulated and observed yield as the degree of precision of the comparison increase as the RMSE tends toward zero. The value of modeling efficiency, EF between the simulated and observed dry yields of tomato is 0.13 which is in line with the work of [Ebrahimipak *et al.* \(2022\)](#) whose studies recorded an EF value of 0.41 for comparing AquaCrop simulated and the observed dry yield of tomato. The modeling efficiency ranges from $-\infty$ to 1 with an EF value of 1 corresponding to a perfect match of the predicted to the observed value. The closer the efficiency approximation is to 1, the better the model's values. The coefficient of residual mass, CRM between the observed and the simulated result is -0.11 which indicated that AquaCrop slightly overestimated the dry yield and this is consistent works of [Rinaldi *et al.* \(2011\)](#) and [Jadhav *et al.* \(2022\)](#) who obtained CRM values of -0.31 and -0.06 for comparing the observed and simulated yields. The CRM values range from $-\infty$ to 1 with an optimum value of 0. A CRM value greater than 0 indicates underestimation. A negative value revealed an overestimation of the model. The observed and simulated results for the dry yield of tomato are presented in Figure 12.

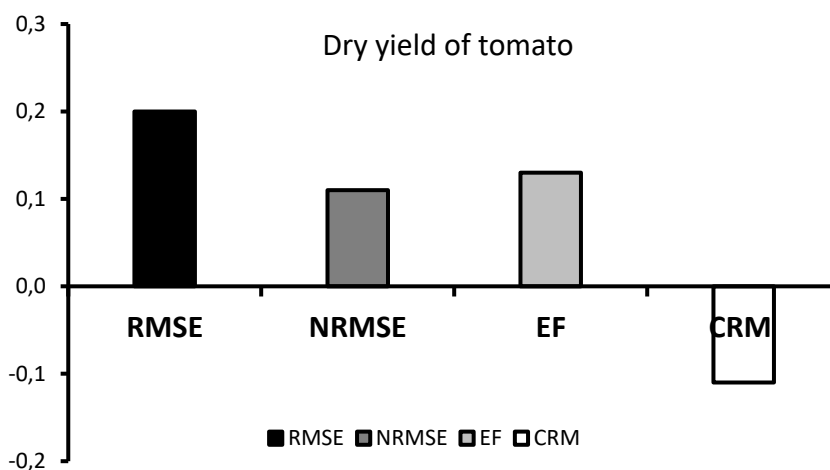

Figure 12. Observed and simulated comparative results for the dry yield of tomato.

In addition to statistical indices used to compare the simulated and observed yields, the t-test was also conducted with the aim to determine if there is a significant difference between the simulated and observed yields and the result of the t-test ($p > 0.05$) reveals no significant difference between the simulated and observed tomato yield.

Comparing Simulated and Observed Water Productivity of Tomato

The values of RMSE, NRMSE, EF and CRM used in comparing the observed and the AquaCrop water productivity of tomato are 0.11, 22%, 0.44 and -0.20. The value of the RMSE of 0.11 shows good agreement the simulated is compared with the observed values of water productivity and has concur with the works of [Sang \(2020\)](#); [Farrokhi et al. \(2021\)](#) and [Ebrahimipak et al. \(2022\)](#) whose studies recorded RMSE values of 0.04, 0.23 and 0.02 respectively for comparing the simulated and observed values of water productivity of tomato. The NRMSE value obtained from the comparison is 22% which is termed acceptable (20% to 30%). This value of NRSME (22%) contradicts the values of NRMSE obtained by [Vegu et al., \(2018\)](#) and [Ebrahimipak et al. \(2022\)](#) of 3.1% and 0.03% respectively.

The value of EF obtained is 0.44 which is considered average and is consistent with the value of EF obtained by [Farrokhi et al. \(2021\)](#) and [Ebrahimipak et al. \(2022\)](#) of 0.23 and 0.19 respectively for comparing the observed and AquaCrop simulated water productivity of tomato. The value of CRM obtained for the comparison is -0.20 which shows that AquaCrop slightly overestimated the water productivity of tomato and this is in line with what was reported by [Salemi et al. \(2011\)](#) who obtained CRM of -0.20 for comparing the simulated and observed water productivity. The t-test was further conducted to determine whether there is a significant difference between the observed and simulated value and the result of the t-test ($p > 0.05$) shows that there is no significant difference between the simulated and observed water productivity of the tomato. The observed and simulated comparative results of water productivity of tomato are shown in Figure 13.

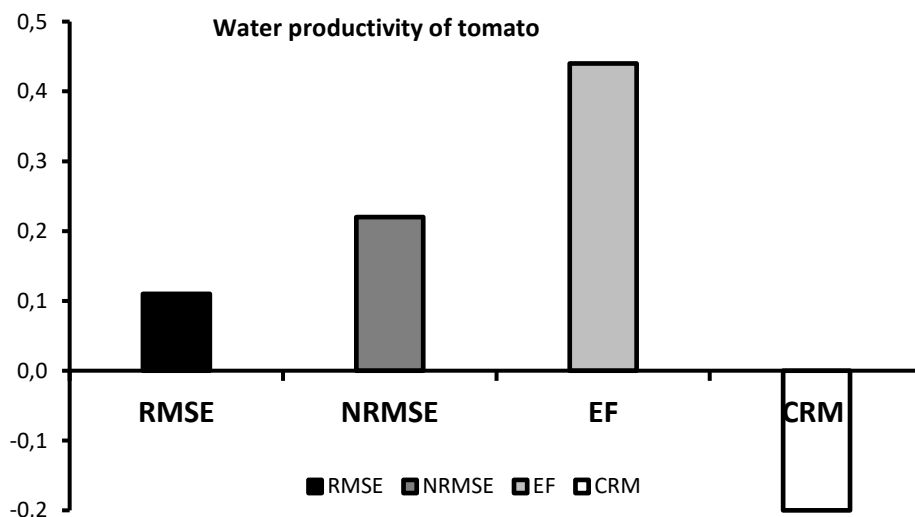

Figure 13. Observed and simulated comparative results for the water productivity of tomato.

Comparing Observed and Simulated Dry Biomass of Tomato

The values of the RMSE, NRMSE, EF and CRM used in comparing the observed and the simulated results of the aboveground dry biomass are 0.21, 5%, 0.16 and -0.06 respectively. The simulated and observed values are approximately similar as indicated by the values of the statistical indices used in their comparison. The value of RMSE (0.21) obtained from the comparison agrees with the works of [Hendy *et al.* \(2019\)](#); [Takács *et al.* \(2019\)](#); [Sang \(2020\)](#) and [Cheng *et al.* \(2022\)](#) whose comparison between the observed and simulated aboveground biomass of tomato recorded RMSE of 0.20, 0.45, 0.60 and 0.53 respectively. The value of NRMSE (5%) obtained shows that the comparison is excellent ($NRMSE < 10\%$) and is in line with the works of [Vegu *et al.* \(2018\)](#); [Hendy *et al.* \(2019\)](#); [Thangaraju \(2020\)](#); [Cheng *et al.* \(2022\)](#); [Muroyiwa *et al.* \(2022\)](#) who used AquaCrop to simulate aboveground biomass of tomato and obtained NRMSE value of 4.7%, 1.9%, 5.9%, 9.7% and 5.2% respectively by comparing the simulated and observed biomass. However, the value of NRMSE (5%) obtained from the comparison contradicts the works of [Takács *et al.* \(2021\)](#) and [Farrokhi *et al.* \(2021\)](#) whose NRMSE ($> 10\%$) values are 12.1% and 16.26% respectively.

The EF value obtained from the comparison is 0.16 which is similar to the values obtained by [Sang \(2020\)](#); [Cheng *et al.* \(2022\)](#) when compared between the observed and AquaCrop simulated aboveground biomass of 0.16 and 0.77 respectively. The CRM value obtained between the results obtained from the simulated and observed biomass result is -0.06 which indicated a very little overestimation of the biomass by the AquaCrop model. The value of CRM obtained from the comparison is in agreement with the values of CRM obtained by [Rinaldi *et al.* \(2011\)](#) of -0.20 who also compared observed and simulated biomass of tomato. AquaCrop is known to overestimate biomass for tomato crops at the final stage of its growing season as reported by [Katerji *et al.* \(2013\)](#). The t-test ($p > 0.05$) conducted shows no significant difference between the simulated and observed aboveground biomass of tomato. The simulated and observed comparative results for the dry biomass of tomato are presented in Figure 14.

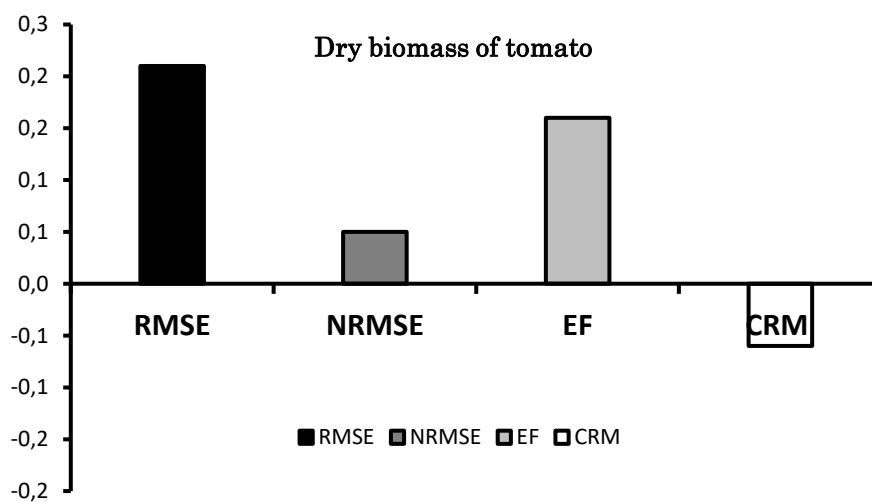

Figure 14. Observed and simulated comparative results for the dry biomass of tomato.

Generally, the AquaCrop simulation model performed remarkably well in simulating the dry yield, dry biomass and water productivity of the tomato crop. All the statistical indices except CRM used in comparing the observed and simulated values revealed a good agreement between the simulated and observed values. The CRM value of -0.11, -0.06 and -0.20 was obtained for the dry yield, dry biomass and water productivity although indicate a slight overestimation of the model they are also closer to the optimum value of 0. More so, the t-test ($p > 0.05$) conducted shows no significant difference between the simulated and observed dry yield, dry biomass and water productivity of the tomato.

Optimized Yield and Yield Components of Tomato

Table 6 presents the optimal values of the simulated dry yield (objective function) and the dry yield parameters obtained using the evolutionary optimization algorithm (genetic algorithm) using MATLAB programming software. The objective function set to maximise the dry yield which is the AquaCrop governing equation is expressed below.

$$\text{Maximise, } Y = K_{S_{wp}} \frac{Y(\text{expt})}{ET} \sum \left(\frac{Tr_i}{ET_{O_i}} \right) \times \frac{MY}{FPW + MY + NMY}$$

The value of the optimized dry yield of 4.496 ton ha⁻¹ is higher than the simulated yields of 2.10 ton ha⁻¹ and 1.76 ton ha⁻¹ for units A and B respectively. This shows that the GA has maximized the simulated yields by about 53 and 61% respectively. The dry biomass computed from the optimal parameters is 4.90 ton ha⁻¹ which is also higher than the simulated values of 3.6 ton ha⁻¹ and 4.0 ton ha⁻¹ for units A and B respectively. This also indicates that dry biomass has been maximized by 27% and 18% for units A and B. The study conforms with the work of [Abdollah et al. \(2022\)](#) who recorded an increase of 63% and 22% in water conservation and yield for optimizing irrigation practices.

This study further agrees with the work of [Seidel \(2012\)](#) who achieved 22% and 76% for water productivity and nitrogen use efficiency using an optimization framework. [Saberi et al. \(2020\)](#), also recorded a remarkable increase in the water use efficiency of 14.2% using a simulation–optimization framework.

Table 6. Optimal values of the simulated dry yield and the optimization parameters.

| S/No. | Parameters | Symbol | Optimal values | Unit |
|-------|------------------------------------|-------------------|----------------|--|
| 1 | Soil fertility stress coefficient | $K_{S_{wp}}$ | 1 | |
| 2 | Yield | Y_{expt} | 19,025.308 | kg ha ¹ |
| 3 | Crop transpiration | ET | 4,000.001 | m ³ ha ⁻¹ season ⁻¹ |
| 4 | Daily transpiration | Tr_i | 8.247 | mm day ⁻¹ |
| 5 | Daily reference evapotranspiration | ET_{O_i} | 8.000 | mm day ⁻¹ |
| 6 | Total Fresh plant weight | $TFPW$ | 29.800 | ton ha ⁻¹ |
| 7 | Marketable yield | MY | 2.700 | ton ha ⁻¹ |
| 8 | Non-marketable yield | NMY | 0.000 | ton ha ⁻¹ |
| 9 | Objective function (dry yield) | Y | 4.496 | ton ha ⁻¹ |

Figure 15 shows the fitness value of the optimization result (optimal dry yield of tomato) after 800 iterations. The figure indicates the best function in each generation versus the iteration during the optimization process. Thus, the fitness value of an individual corresponds to the fitness function for that particular individual. The black dots/marks indicate the best fitness values whereas the blue dots/marks indicate the mean fitness values in each generation. The fitness function is a measure of how close a given solution is to the optimum solution of the desired problem and the best fitness value is equal to the objective function. The fitness value improves rapidly in the early generations and more slowly in later generations which is quite similar to the general optimization problems (Hanan et al., 2016). The MATLAB programming software searches for the minimum of the function and hence, the best fitness value for a given population is the smallest value for a given individual in that particular population. The best fitness value of dry yield of tomato was found to be -4.960 which translates to 4.960 ton ha⁻¹ton because the objective function of the optimization process was to maximize the dry yield of tomato.

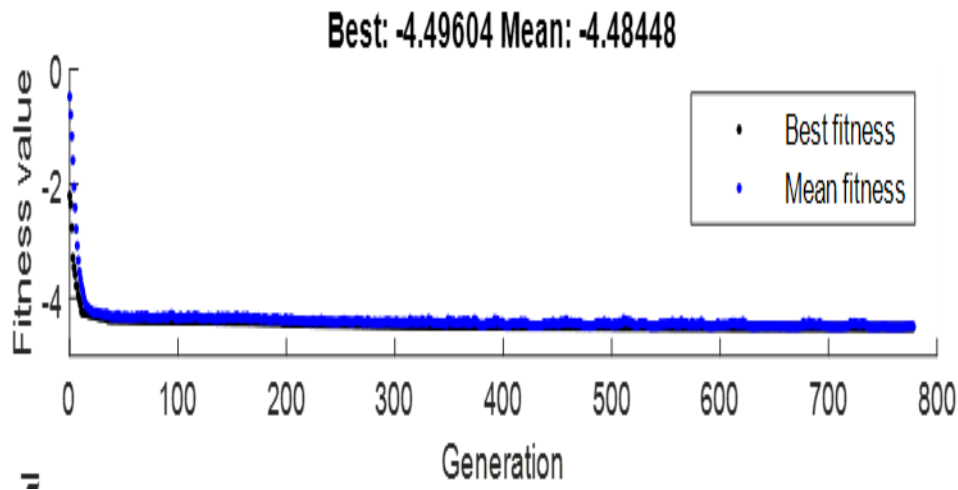

Figure 15. Best and the mean fitness of the dry yield of tomato.

CONCLUSION

The AquaCrop simulation model performed remarkably well in simulating the observed yield, aboveground biomass and water productivity of tomato based on results of RMSE (0.20, 0.21 and 0.11), NRMSE (11%, 5% and 22%), EF (0.13, 0.16 and 0.44) and CRM (-0.11, -0.06 and -0.20) used in comparing the simulated and observed results. All the statistical indices except CRM show good agreement between the observed and simulated results. The CRM value of -0.11, -0.06 and -0.20 was obtained for yield, biomass and water productivity although indicate a very slight overestimation of the model they are also closer to the optimum value of zero (0). The t-test ($p > 0.05$) conducted between the observed and simulated results also shows that there is no significant difference between the simulated and observed results.

The result of the optimization revealed the optimal values of yield and aboveground biomass of 4.49 ton ha⁻¹ and 4.90 ton ha⁻¹ respectively. This shows that

the GA has maximized the simulated yields by 53% and 61% respectively for units A and B. The GA has also maximized aboveground biomass by 27% and 18% for units A and B. The GA has therefore proved to be an effective tool for improving the yield and the yield components of tomato crops.

DECLARATION OF COMPETING INTEREST

We hereby declare that we have no conflict of interests

CREDIT AUTHORSHIP CONTRIBUTION STATEMENT

Nura Jafar Shanono, Investigation, methodology, conceptualization, data curation, validation, review, and editing, visualization,

Lawal Ahmad, Investigation, methodology, data curation, review, and editing, visualization,

Nuraddeen Mukhtar Nasidi, Formal analysis, data curation, review, and editing, visualization,

Abdul'aziz Nuhu Jibril, Methodology, formal analysis, validation, review, and editing, visualization,

Mukhtar Nuhu Yahya, Investigation, methodology, validation, writing - original draft.

ETHICS COMMITTEE DECISION

This article does not require any ethical committee decision.

REFERENCES

- Abdollah S, Ali A, Ritzema H, Dam J Van and Hellegers P (2022). A combined model approach to optimize surface irrigation practice: SWAP and WinSRFR. *Agricultural Water Management*, 271 (December 2021), 107741. <https://doi.org/10.1016/j.agwat.2022.107741>
- Ahmad MT and Haie N (2018). Assessing the impacts of population growth and climate change on performance of water use systems and water allocation in Kano River basin, Nigeria. *Water (Switzerland)*, 10(12). <https://doi.org/10.3390/w10121766>
- Akbari M, Gheysari M, Mostafazadeh-Fard B and Shayannejad M (2018). Surface irrigation simulation-optimization model based on meta-heuristic algorithms. *Agricultural Water Management*, 201 (January), 46-57. <https://doi.org/10.1016/j.agwat.2018.01.015>
- Ara I, Turner L, Harrison MT, Monjardino M, deVoil P and Rodriguez D (2021). Application, adoption and opportunities for improving decision support systems in irrigated agriculture: A review. *Agricultural Water Management*, 257 (June), 107161. <https://doi.org/10.1016/j.agwat.2021.107161>
- Bitri M, Grazhdani S and Ahmeti A (2014). Validation of the aquacrop model for full and deficit irrigated potato production in environmental condition of Korça Zone, South-Eastern Albania. *International Journal of Innovative Research in Science, Engineering and Technology*, 3(4): 1-8.
- Cheng M, Wang H, Fan J, Xiang Y, Liu X, Liao Z, Elsayed A, Zhang F and Li Z (2022). Evaluation of AquaCrop model for greenhouse cherry tomato with plastic film mulch under various water and nitrogen supplies. *Agricultural Water Management*, 274 (July), 107949. <https://doi.org/10.1016/j.agwat.2022.107949>
- Ebrahimipak NA, Egdernezhad A, Tafteh A and Ansari MA (2022). The effect of irrigation water management and fertilizer amount on aquacrop accuracy and efficiency for tomato yield and water use efficiency simulation. *Iranian Journal of Irrigation and Water Engineering*, 47(3): 121-136. <https://doi.org/10.22125/IWE.2020.243948.1405>

- Eiben AE and Smith JE (2015). Introduction to evolutionary computing. In Kybernetes (Second, Vol. 33). Springer Berlin Heidelberg. <https://doi.org/10.1108/03684920410699216>
- Farrokhi E, Mahallati MN, Koocheki A and Beheshti SA (2021). Simulation of growth and development of tomato (*Lycopersicon esculentum* Mill.) under drought stress: 2- Simulation of growth and water productivity, Above ground biomass and yield. *Journal of Water and Soil*, 35(5): 627-643. <https://doi.org/10.22067/JSW.2021.15035.0>
- Gaelen HV, Tsegay A, Delbecque N, Shrestha N, Garcia M, Fajardo H, Miranda R, Vanuytrecht E, Abrha B, Diels J and Raes D (2015). A semi-quantitative approach for modelling crop response to soil fertility: Evaluation of the AquaCrop procedure. *Journal of Agricultural Science*, 153(7): 1218-1233. <https://doi.org/10.1017/S0021859614000872>
- Hadebe ST, Modi AT and Mabhaudhi T (2017). Calibration and testing of AquaCrop for selected sorghum genotypes. *Water SA*, 43(2): 209-221. <https://doi.org/10.4314/wsa.v43i2.05>
- Hanan L, Qiushi L and Shaobin L (2016). An integrated optimization design method based on surrogate modeling applied to diverging duct design. *International Journal of Turbo and Jet Engines*, 33(4): 395-405. <https://doi.org/10.1515/tjj-2015-0042>
- Hendy ZM, Attaher SM, Abdelhady SA, Abdel-aziz AA and El-Gindy AEGM (2019). Simulation of the effect of deficit irrigation schemes on tomato crop production using aquacrop model. *Misr Journal of Agricultural Engineering*, 36(1): 175-194.
- Heng LK, Hsiao T, Evett S, Howell T and Steduto P (2009). Validating the FAO aquacrop model for irrigated and water deficient field maize. *Agronomy Journal*, 101(3): 488-498. <https://doi.org/10.2134/agronj2008.0029xs>
- Ikudayisi A and Adeyemo J (2015). Irrigation water optimization using evolutionary algorithms. *Environmental Economics*, 6(1): 200-205.
- Isah AS, Amans EB, Odion EC and Yusuf AA (2014). Growth rate and yield of two tomato varieties (*Lycopersicon esculentum* mill) under green manure and NPK fertilizer rate Samaru northern guinea savanna. *International Journal of Agronomy*, 2014(1): 1-8. <https://doi.org/10.1155/2014/932759>
- Jadhav R, Jadhav SB, Awari HW, Ingle VK and Khodke UM (2022). Assessment of AquaCrop Model for irrigated cotton under deficit irrigation in semi-arid tropics of Maharashtra. *International Journal of Current Microbiology and Applied Sciences*, 11(01): 123-135. <https://doi.org/https://doi.org/10.20546/ijcmas.2022.1101.015>
- Jame YW and Cutforth HW (1996). Crop growth models for decision support systems. *Plant Science*, 76, 9-19. <https://doi.org/197.210.70.172 on 11/16/21>
- Jiang Y, Xu X, Huang Q, Huo Z and Huang G (2016). Optimizing regional irrigation water use by integrating a two-level optimization model and an agro-hydrological model. *Agricultural Water Management*, 178: 76-88. <https://doi.org/10.1016/j.agwat.2016.08.035>
- Katerji N, Pasquale C and Mastrolli M (2013). Productivity, evapotranspiration, and water use efficiency of corn and tomato crops simulated by AquaCrop under contrasting water stress conditions in the Mediterranean region. *Agricultural Water Management*, 130: 14-26. <https://doi.org/https://doi.org/10.1016/j.agwat.2013.08.005>
- Kephe PN, Ayisi KK and Petja BM (2021). Challenges and opportunities in crop simulation modelling under seasonal and projected climate change scenarios for crop production in South Africa. *Agriculture and Food Security*, 10(1): 1-24. <https://doi.org/10.1186/s40066-020-00283-5>
- Kloss S, Schütze N and Schmidhalter U (2014). Evaluation of very high soil-water tension threshold values in sensor-based deficit irrigation systems. *Journal of Irrigation and Drainage Engineering*, 140(9). [https://doi.org/10.1061/\(asce\)ir.1943-4774.0000722](https://doi.org/10.1061/(asce)ir.1943-4774.0000722)
- Ko J, Piccinni G, Guo W and Steglich E (2009). Parameterization of EPIC crop model for simulation of cotton growth in South Texas. *Journal of Agricultural Science*, 147: 169-178. <https://doi.org/10.1017/S0021859608008356>
- Lawal A and Shanono NJ (2022). *Development and testing of sensor-based drip irrigation to improve tomato production in semi-arid Nigeria*. Proceedings of the 22nd International Conference and 42nd Annual General Meetings of the Nigerian Institution of Agricultural Engineers (A Division of Nigerian Society of Engineers) Niae Conference September 20th -24th, 2022 | ASABA, NIGERIA, September, 103-111.
- Li M, Fu Q, Singh V, Liu D and Gong X (2020). Risk-based agricultural water allocation under multiple uncertainties. *Agricultural Water Management*, 233(4): 106105.

- McCarthy AC, Hancock NH and Raine SR (2013). Advanced process control of irrigation: the current state and an analysis to aid future development. *Irrigation Science*, 31: 183-192. <https://doi.org/dx.doi.org/10.1007/s00271-011-0313-1>
- Muroyiwa GATM, Mashonjowa E and Muchuweti M (2022). Evaluation of FAO AquaCrop Model for ability to simulate attainable yields and water use for field tomatoes grown under deficit irrigation in Harare, Zimbabwe. *African Crop Science Journal by African Crop Science Society*, 30(2), 245-269. <https://doi.org/https://dx.doi.org/10.4314/acsj.v30i2.10>
- Perea RG, Daccache A, Di'az JAR, Poyato EC and Knox JW (2017). Modelling impacts of precision irrigation on crop yield and in-field water management. *Precision Agriculture*, 19: 497-512. <https://doi.org/https://doi.org/10.1007/s11119-017-9535-4>
- Raes D, Steduto P, Hsiao TC and Feres E (2022). AquaCrop Version 7.0 Reference manual; Chapter 1 FAO crop-water productivity model to simulate yield response to water (Issue August). Food and Agriculture Organization of the United Nations. <https://www.fao.org/3/br246e/br246e.pdf>
- Reynolds M, Kropff M, Crossa J, Koo J, Kruseman G, Molero Milan A, Rutkoski J, Schulthess U, Singh B, Sonder K, Tonnang H and Vadez V (2018). Role of modelling in international crop research: Overview and some case studies. *Agronomy* 8(12): 291.
- Rinaldi M, Garofalo P, Rubino P and Steduto P (2011). Processing tomatoes under different irrigation regimes in Southern Italy: agronomic and economic assessments in a simulation case study. *Italian Journal of Agrometeorology* 3(3): 39-56.
- Saberi E, Khashei Siuki A, Pourreza-Bilondi M and Shahidi A (2020). Development of a simulation-optimization model with a multi-objective framework for automatic design of a furrow irrigation system. *Irrigation and Drainage*, 69(4): 603-617. <https://doi.org/10.1002/ird.2460>
- Salemi H, Amin M, Soom M, Mousavi S and Ganji A (2011). Irrigated silage maize yield and water productivity response to deficit irrigation in an arid region. *Polish Journal of Environmental Studies*, 20(5). <https://doi.org/https://www.researchgate.net/publication/275953655>
- Sang HJ (2020). *Optimisation of tomato water productivity under deficit sub-surface drip irrigation and mulching systems*. Egerton University.
- Seidel S (2012). *Optimal simulation based design Dresdner Schriften zur Hydrologie*.
- Shanono NJ (2019). *Assessing the impact of human behaviour on reservoir system performance using dynamic co-evolution*. A PhD Thesis Submitted to University of the Witwatersrand, Johannesburg. <https://doi.org/http://wiredspace.wits.ac.za/handle/10539/29043>
- Shanono NJ, Nasidi NM, Zakari MD and Bello MM (2014). Assessment of field channels performance at watari irrigation project Kano, Nigeria. 1st International Conference on Dryland, Center for Dryland Agriculture, Bayero University Kano, Nigeria. 8th-12th December, 2014, 144-150.
- Shanono NJ, Othman MK, Nasidi NM and Isma'il H (2012). *Evaluation of Soil and water quality of watari irrigation project in semi-arid region, Kano, Nigeria*. Proceedings of the 33rd National Conference and Annual General Meeting of the Nigerian Institute of Agricultural Engineers (NIAE) Bauchi., 181-186.
- Shanono NJ, Abba BS and Nasidi NM (2022). Evaluation of Aqua-Crop Model using onion crop under deficit irrigation and mulch in semi-arid Nigeria. *Turkish Journal of Agricultural Engineering Research (TURKAGER)*, 3(1): 131-145. <https://doi.org/10.46592/turkager.1078082>
- Singels A, Annandale JG, Jager JM De, Schulze RE, Durand W, Rensburg LD Van, Heerden PS Van, Crosby CT, Green GC and Steyn JM (2013). Modelling crop growth and crop water relations in South Africa: Past achievements and lessons for the future. 1862. <https://doi.org/10.1080/02571862.2010.10639970>
- Singh A (2012). An overview of the optimization modelling applications. *Journal of Hydrology*, 466-467(August), 167-182. <https://doi.org/10.1016/j.jhydrol.2012.08.004>
- Steduto P, Hsiao TC and Feres E (2012). Crop yield response to water. Food and Agricultural Organisation. www.fao.org
- Takács S, Csengeri E, Pék Z, Bíró T, Szuvandzsiev P, Palotás G and LH (2021). Performance evaluation of aquacrop model in processing tomato biomass, fruit yield and water stress indicator modelling. *Water*, 13(3587). <https://doi.org/https://doi.org/w13243587>
- Takács S, Rác I, Csengeri E and Bíró T (2019). Biomass production estimation of processing tomato using AquaCrop under different irrigation treatments. *Acta Agraria Debreceniensis*, 2: 131-136. <https://doi.org/10.34101/actaagrar/2/3691>
- Thangaraju NKA (2020). *Predicting crop water requirements and yield for tomato under a humid climate (Issue April)* [McGill University, Montreal]. <https://escholarship.mcgill.ca/theses>

- Thompson RB and Gallardo M (2005). Use of Soil moisture sensors for irrigation scheduling. "improvement of water use efficiency in protected crops, January, 1–6. https://doi.org/https://www.researchgate.net/publication/285422793_Use_of_soil_sensors_for_irrigation_scheduling/link/566481dc08ae418a786d6a93/download
- Vegu G, Geethalakshmi V and Bhuvanewari K (2018). Evaluation of the AquaCrop Model for simulating yield response of tomato crop over Thiruchirapalli District Of Tamilnadu. *Journal in Science, Agriculture & Engineering*, 7(Special issue).
- Walser S, Schütze N, Marcus G, Susanne L and Schmidhalter U (2011). Evaluation of the transferability of a SVAT model--results from field and greenhouse applications. *Irrigation and Drainage*, 60(Suppl. 1): 59-70. <https://doi.org/10.1002/ird.669>
- Whitley D (2001). An overview of evolutionary algorithms: Practical issues and common pitfalls. *Information and Software Technology*, 43(14): 817-831. [https://doi.org/10.1016/S0950-5849\(01\)00188-4](https://doi.org/10.1016/S0950-5849(01)00188-4)