

DETERMINATION OF MERCURY, LEAD, CADMIUM, COPPER, IRON AND MANGANESE IN SHEEP, COW AND CHICKEN LIVER SAMPLES IN TURKEY

Onur Yayayürük*, Aslı Erdem Yayayürük

Ege University, Faculty of Science, Department of Chemistry, İzmir, Turkey

Geliş / Received: 13.02.2017; Kabul / Accepted: 01.06.2017; Online baskı / Published online: 07.07.2017

Yayayürük, O., Erdem Yayayürük, A. (2017). Determination of mercury, lead, cadmium, copper, iron and manganese in sheep, cow and chicken liver samples in Turkey. *GIDA* (2017) 42 (5): 546-552 doi: 10.15237/gida.GD17018

Abstract

Liver is the most important organ involved in metabolic processes and is considered to be one of the most eloquent witnesses of any disturbance in the body. The aim of the present study is to determine mercury, lead, cadmium, copper, iron and manganese concentrations in sheep, cow and chicken liver samples. The validation of the method was confirmed by analysis of standard reference material (BCR CRM 422 Cod Muscle). Levels of copper in the sheep and cow 640 and 675 mg/kg, respectively and were the highest in the animal livers examined. The concentration of other metals in liver samples were found in the range of 17.2-402 µg/kg for mercury, 129-411 mg/kg for iron and 30.2-141 mg/kg for manganese. Chicken liver samples were found to contain the highest amount of the mercury and manganese analyzed. With regard to the fact that in some samples maximum allowable limits for liver samples were exceeded, effective ecological measures should be taken that would have a beneficial effect on the landscape and environment.

Keywords: Liver, heavy metal, sheep, cow, chicken.

TÜRKİYE'DEKİ KOYUN, DANA VE TAVUK KARACİĞER ÖRNEKLERİNDE CİVA, KURŞUN, KADMİYUM, BAKIR, DEMİR VE MANGAN TAYİNİ

Abstract

Karaciğer, metabolik süreçlerde yer alan en önemli organ olup, vücudun herhangi bir rahatsızlığının en belirgin tanıklarından biri olarak değerlendirilir. Bu çalışmanın amacı, koyun, dana ve tavuk karaciğer örneklerindeki cıva, kurşun, kadmiyum, bakır, demir ve mangan derişimlerini tayin etmektir. Metot validasyonu, standart referans materyalin (BCR CRM 422 Morina balığı kası) analizi ile gerçekleştirilmiştir. İncelenen hayvan karaciğerlerinden koyun ve danada bakır seviyesi 640-675 mg/kg aralığında bulunmuştur. Karaciğer örneklerinde diğer metallerin derişimleri sırasıyla cıva için 17.2-402 µg/kg, demir için 129-411 mg/kg ve mangan için 30.2-141 mg/kg aralığında bulunmuştur. Cıva ve mangan ise tavuk karaciğer örneklerinde en yüksek miktarda bulunmuştur. İncelenen bazı karaciğer örneklerinde, izin verilen maksimum sınırların aşıldığı belirlendiğinden etkili ekolojik önlemlerin alınması toplum ve çevre üzerinde yararlı bir etkiye sahip olacaktır.

Anahtar kelimeler: Karaciğer, ağır metal, koyun, dana, tavuk.

* Corresponding author / Yazışmalardan sorumlu yazar

✉ onur.yayayuruk@ege.edu.tr,

☎ (+90) 232 311 1770,

☎ (+90) 232 388 8264

INTRODUCTION

Heavy metals are recognized as important contaminants in environmental systems due to their high potential to accumulate and enter in food chains (Sipahi et al., 2013; Erdoğan and Erbilir, 2007). The main sources of heavy metal pollution are the industry, agriculture and mining activities (Kumar et al., 2007). Heavy metals can be classified as potentially toxic (mercury, cadmium, aluminum, arsenic, lead, etc.), probably essential (cobalt, vanadium and nickel) and essential (iron, selenium, copper, zinc and manganese) (Jalbani et al., 2007; Munoz-Olivas and Camara, 2001; Falandysz et al., 2007). If the toxic elements are ingested over a long period, they can be very harmful even at low concentrations. In addition to this, essential metals can also produce toxic effects when the metal intake is excessively elevated (Pouretedal and Rafat, 2007; Tuzen, 2003; Celik and Oehlschlager, 2007).

The improvements in the food production and processing technology increased the chances of contamination of food with various environmental pollutants, especially heavy metals. Therefore the risk associated with the exposure to heavy metals present in foodstuffs represents a concern in human health (Yüzbaşı and Sezgin, 2002). The understanding of the total level of heavy metals in foodstuffs is very important in order to set dietary requirements. Moreover determination of the concentration of the distinct element species in foodstuffs is also required to estimate the nutritional quality and food safety.

Liver is the most important organ involved in metabolic processes and considered to be one of the most eloquent witnesses of any disturbance in the body, as it is the subject of different types of infectious, toxic, metabolic, nutritional, traumatic attacks or diseases (Doneley, 2004). Moreover due to the presence of metal-binding proteins in liver, heavy metals can accumulate at high concentrations; therefore special attention should be given in order to determine the concentration of heavy metals in this organ. Sedki and his coworkers (2003) have determined zinc (Zn) cadmium (Cd) and copper (Cu) levels in muscle, bone, liver and kidney of bovine grazing on the municipal wastewater spreading field of Marrakech City (Morocco). Bovines were found to be seriously contaminated by toxic metals,

especially cadmium. The levels of metals were found to highest in liver and kidney which are known as specific target organs for metal bioaccumulation. The arithmetic mean concentrations of zinc, copper and cadmium in liver and kidney were 126, 112 and 5.1 mg/g in liver; 89, 33 and 10.µg/g in kidney, respectively. Oyaro et al. (2007) have determined Pb, Zn, Cd and Cu contents in meat samples of the kidney, liver and muscles from various cattle taken from Nairobi and its surroundings. The overall concentration of Pb, Cu, Cd and Zn were below 2 mg/L. It was evaluated that the muscle had high concentrations of Pb and Cd as compared with kidney and liver. This situation was associated with the butcherries located along the highway with high vehicular density, so there was a high possibility of direct deposition of Pb and Cd in the meat samples. Koréneková et al. (2002) have analyzed muscle and liver samples of 21 cattle from an area polluted by a metallurgical plant for the presence of Cd, Pb, Ni, Zn, Cu and Fe. The highest mean levels of heavy metals were recorded in the liver as Pb 1.072; Cd 0.456; Zn 79.946; Cu 84.091; Fe 146.822; Ni 0.231 mg/kg, respectively. The highest mean levels in the muscle were Pb 0.671; Cd 0.126; Zn 81.180; Cu 6.312; Fe 51.800; Ni 0.350 mg kg⁻¹, respectively. The results obtained in the study indicated that the contents of heavy metals in the vicinity of the metallurgical plant are ecologically important, mainly of Cd and Pb.

The aim of the present study is to determine Hg, Pb, Cd, Cu, Fe and Mn concentrations in sheep, cow and chicken liver samples by cold vapor atomic fluorescence spectrometry and/or flame atomic absorption spectrometry after open digestion. Moreover, the data were assessed by comparing estimates of dietary exposures with recommended dietary allowances (RDA) recommended by the World Health Organization (WHO, 1993).

EXPERIMENTAL

Samples

Liver samples of sheep, cow and chicken were collected randomly from the different retail markets and butchers in İzmir, the third most populous city of Turkey. A total of thirty liver

samples were collected from these areas, kept in refrigerator prior to digestion and analyzed after open digestion.

Reagents

All reagents were of analytical reagent grade unless otherwise stated. All the plastic and glassware were cleaned by soaking in dilute HNO_3 (1 + 9) and rinsed with distilled water prior to use. Ultra-pure water (18.2 $\text{M}\Omega$) was used for all dilutions. HNO_3 and H_2O_2 were of suprapure quality (Merck, Germany). A 1000 mg/L mercury stock solution was prepared by dissolving 0.100 g of elemental mercury in 7.0 mL of concentrated (14.3 M) HNO_3 and diluted to 100.0 mL with ultra-pure water. 1000 mg/L lead, cadmium, copper, iron and manganese stock solutions were prepared from analytical reagent grade compounds (Merck, Germany). Standards with lower concentrations were prepared daily in 0.01 M HCl from their stock standard solutions. For mercury determinations, SnCl_2 (3% w/v) was prepared daily in HCl (15% v/v) and used as the reducing agent.

Instrumentation

A PSA 10.004 Merlin Plus atomic fluorescence spectrometer (Kent, UK) was used for the

determination of mercury. The scheme of the fluorescence measurement system and the measurement conditions can be found in Figure 1 and Table 1, respectively. All measurements were carried out using high-purity argon gas as a carrier and drying gas. The peak height was used for quantitation. Varian SpectraAA 220 FS model atomic absorption spectrometer with an air-acetylene flame with respective hollow cathode lamps was used for the determination of Cu, Cd, Fe, Mn and Pb. Deuterium background correction was used in all determinations.

Sample digestion

The liver samples collected were homogenized with a stainless steel knife and dried in the oven (100 °C) for 24 h before digestion. Accurately weighed aliquots (0.3 g) of each dried samples were digested with 5.0 mL of concentrated HNO_3 and 5.0 mL of concentrated H_2O_2 on a hotplate and heated for 3.0 h. After digestion, sulfamic acid was added (it is necessary for matrix removal in mercury determination) and heated for 5.0 minutes and then the volume of the solutions were adjusted to 25.0 mL with ultra-pure water. A blank digest was carried out in the same way. All sample solutions were clear. The accuracy of the digestion method was checked by a standard reference material (BCR CRM 422 Cod Muscle).

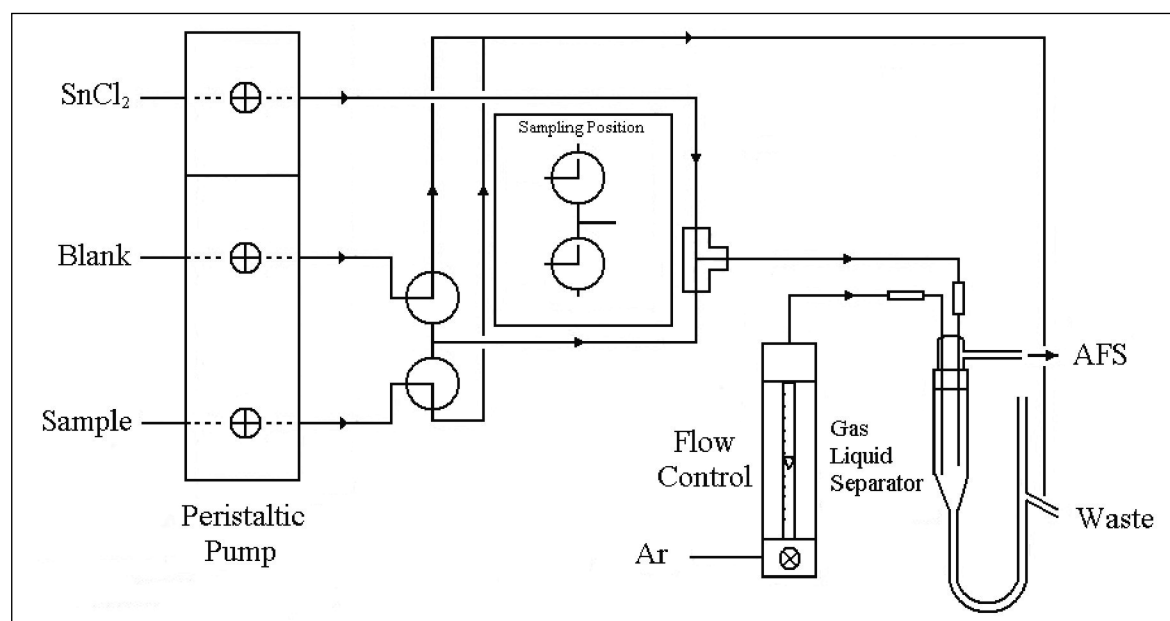

Figure 1. Diagram of the mercury flow system.

Table 1. Instrumental operating parameters for FAAS and CV-AFS.

FAAS	Element	Cu	Fe	Mn
	System type	Flame	Flame	Flame
	Lamp current (mA)	3.0	7.0	5.0
	Wavelength (nm)	324.7	248.3	279.5
	Spectral bandpass (nm)	0.5	0.2	0.2
	Slit height	Normal	Normal	Normal
	Instrument mode	Absorbance BC on	Absorbance BC on	Absorbance BC on
	Sampling mode	Manuel	Manuel	Manuel
	Flame type	Air-Acetylene	Air-Acetylene	Air-Acetylene
	Acetylene flowrate (L min ⁻¹)	1.65	1.65	1.65
	Air flowrate	10.6	10.6	10.6
	Read time (s)	10	10	10
	Replicates	3	3	3
Measurement mode	Peak height	Peak height	Peak height	
CV-AFS	Element	Hg		
	Delay time	5-10 sec		
	Rise time	25 sec		
	Analysis time	0.5 min		
	Memory time	40 sec		
	Carrier gas (Ar)	0.55 L min ⁻¹		
	Shield gas (Ar)	0.1 L min ⁻¹		
	Dryer gas (Ar)	1.5 L min ⁻¹		
	Blank and sample solution	7 mL min ⁻¹		
	SnCl ₂ solution (3%)	3 mL min ⁻¹		

RESULTS AND DISCUSSION

The detection limit values of elements as milligram per kilogram were found to be 2.1 for Cu, 0.75 for Cd, 4.16 for Fe, 1.66 for Mn, 5.0 for Pb and 3.0 µg/kg for Hg. The detection limits of the analyzed elements were determined from the concentration corresponding to three times the standard deviation of ten blanks. The validation of the method used in this study was realized through the analysis of a standard reference material (SRM) using the same procedure by Inductively Coupled Plasma Mass Spectrometry. Student's t-test was used for determining the difference between the certified and determined values. The percent recovery obtained for the SRM was in good agreement with the certified values and within 5% of the certified values for Hg, Cu, Mn and Fe (Table 2). Moreover, no significant difference between the certified values and those that have been obtained in this work was observed according to a Student's t-test on a 95% confidence level for all of the elements analyzed.

Table 2. Recovery results of certified reference material (Cod muscle -BCR 422).

Element (µg/g)	Certified value	Found value	Recovery (%)
Hg	0.559 ± 0.016	0.542 ± 0.025	96.9 ± 4.5
Cu	1.05 ± 0.07	1.01 ± 0.05	96.2 ± 4.8
Fe	5.46 ± 0.30	5.51 ± 0.41	101 ± 7.5
Mn	0.543 ± 0.028	0.53 ± 0.039	97.6 ± 7.2

Trace element levels in sheep, cow and chicken liver are listed in Table 3. Pb and Cd levels in the samples were below the detection limit of flame atomic absorption spectrometry for all of the samples. The concentrations of elements in liver samples were found to be in the range of 26.4–676 mg/kg for copper, 129–411 mg/kg for iron, 17.2–402 µg/kg for mercury and 30.2–141 mg/kg for manganese. According to these results, copper has the highest concentration in the samples investigated followed by iron, manganese and mercury (Figure 2).

Copper is considered to be an essential element both for mammals and plants, and it is required at very low levels (~40 µg/L daily intake) for the lipid and carbohydrate metabolism of the living organisms. High levels of copper may cause several diseases (e.g. nausea, diarrhea) and/or give damage to organs. A high concentration of copper in foods originates mainly from fungicide residues containing this metal used in agriculture and from water plumbing (Gouda and Amin, 2014). The copper contents of samples ranged 223–641, 95–676 and 26.4–50.4 mg/kg for sheep, cow and chicken liver samples, respectively, cow liver has the lowest copper concentration, while chicken recorded the highest value. Although copper is an essential element, high intakes of

Table 3. Results of liver samples analysis (mg/kg dry weight).

		Sheep Liver	Cow Liver	Chicken Liver
Hg ^a	M	30.4	28.1	252
	SD	4.64	7.45	101
	Min.	26.2	17.2	107
	Max.	36.3	33.4	402
Cu	M	414	250	37.2
	SD	150	247	7.86
	Min.	223	95	26.4
	Max.	641	676	50.4
Fe	M	237	180	287
	SD	114	52	72.6
	Min.	129	158	205
	Max.	411	251	385
Mn	M	39.3	39.6	119
	SD	6.77	6.85	18.8
	Min.	34.4	30.2	102
	Max.	47.4	49.2	141

^aµg/kg for Hg, M: mean, SD: standard deviation, Min: minimum, Max: maximum

copper may cause damages to health. The maximum copper concentration for meat and meat products for one person was proposed as 0.9-30 mg per day. In literature, copper levels in liver samples have been reported in the range of 0.070-4.55 mg/L in Kenya, 76-156 µg/g in France. The copper concentrations obtained in this study were higher than those recorded by Uluozlu et. al (2009). This situation may be due to different sampling areas and the butchereries located along the highway with high vehicular density, so there is a high possibility of direct deposition of copper in the samples. Moreover the farm animals reared freely on pasture are the indicators of environmental pollution. By respiration of polluted air and intake of contaminated feed, heavy metal bio accumulates increasingly in organs and tissues of animals.

Iron is the most abundant transition metal in the living system and it is required for a number of vital functions (e.g. to carry oxygen). It is also essential for the proper functioning of numerous enzymes involved in energy metabolism, DNA synthesis, and protection against free radicals and microbes. Excess intake of iron may cause siderosis while its deficiency causes anemia which is widely prevalent in developing countries, especially in the low socio-economic classes of the population. This may cause a major public health problem with many adverse consequences especially in young generation (Alamin et al., 2007). Therefore the levels of iron should be

under control especially in food stuffs. The lowest and highest iron concentrations were found as 129 mg/kg and 411 mg/kg in sheep liver, respectively. No significant difference was evaluated for iron content in sheep, cow and chicken liver samples and higher results were obtained for chicken liver samples when compared with literature (Uluozlu et al., 2009; Alamin et al., 2007). This situation may be due to the high content of iron in the fertilizers which are added to the soil to provide the essential growth of plants.

Manganese is both an essential microelement for human body but also a toxic element for living beings depending on the concentration level. It plays an important role in the proper function of carbohydrate and lipid metabolism, enzymes such as dipeptidase, arginase and phosphatase

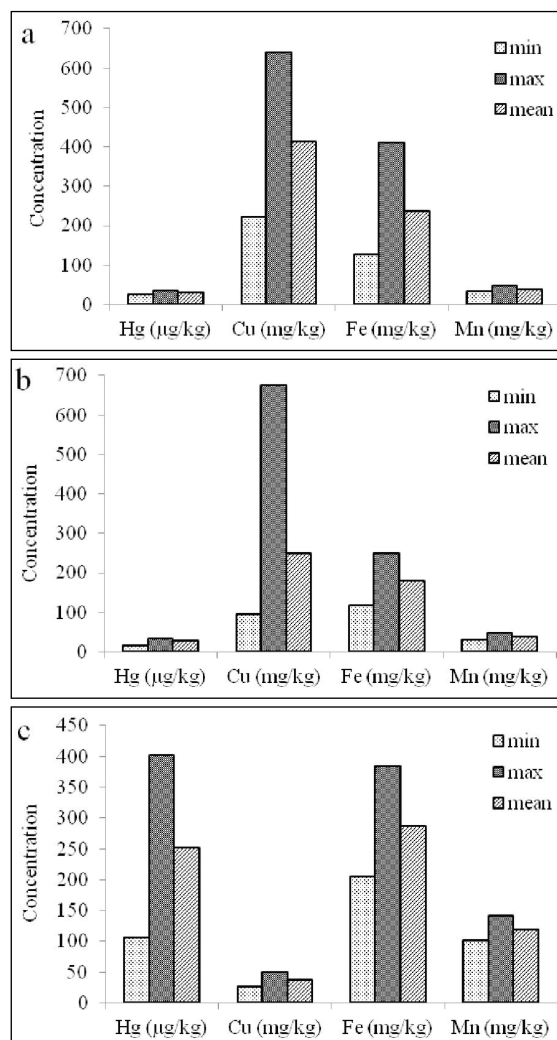

Figure 2. Trace element levels in (a) Sheep liver, (b) Cow liver and (c) Chicken liver.

and in bone and tissue formation. If the dietary intake of manganese is significantly higher, it causes deficiency related to hypercholesterolaemia and delayed blood coagulation (World Health Organization, 1996). A daily dietary intake of 2 to 5 mg is estimated to be adequate for adults (Institute of Medicine, 2003). Chicken liver samples were found to contain the highest amount of manganese (141 mg/kg) while sheep and cow liver samples contained almost the same. This situation may be due to the several commercial organic manganese sources, including amino acid complexes, chelates, and proteinates which have been developed as supplements to chicken feeds (Li et al., 2011).

Mercury is considered as a global pollutant with a high environmental risk which results from both natural and anthropogenic activities. Natural mercury arises from the degassing of the earth's crust through volcanoes and probably by evaporation from the oceans. It also results from burning of petroleum and coal products. Mercury can be accumulated in tissues of animal's organisms which will influence the food chain. It can readily be absorbed by the human body causing damages in the central nervous system (Shah et al., 2010). Moreover, concentration of mercury exceeding the maximum permissible limit (30 µg/kg) in food and food stuff cause serious health problems such as loss of vision, hearing and mental retardation (Khan et al., 2015). The mercury concentrations in the liver samples were significantly higher in chicken than in cows and sheep samples. The mercury concentrations were found in chicken liver samples were found to range between 107-402 µg/kg. Shah et. al have stated that the accumulation of mercury in the tissues of broiler chickens may due to feed prepared from low grade grains and small sea fishes (Shah et al., 2010). This evaluation is in accordance with our study where high levels of mercury have been found in especially chicken liver samples.

CONCLUSIONS

Consumption of foodstuff is one the major ways of human exposure to heavy metals which will threaten population health leading serious diseases. The results obtained in this study have

indicated that sheep, cow and chicken liver samples contained high amounts of copper, iron, manganese and mercury. Levels of copper in the sheep and cow of were the highest in the animal livers examined. This situation may be due to the fact that the farm animals reared freely on pasture so there is high possibility of respiration of polluted air and intake of contaminated feed. Therefore heavy metals may bio accumulate in organs and tissues of animals. Chicken liver samples were found to contain the highest amount of the mercury and manganese analyzed. Since chicken is used as most consumable food item in many countries in the world due to low cost, easily availability and being rich in protein, special consideration should be given to handling and processing of the raw materials. The better selection of the raw material, including an analysis for toxic trace elements prior to processing, could surely improve the present situation.

REFERENCES

- Alamin MB, Mhapes AA, Bejey AM, Sadek A, Atweer RH, Dubali K, Saad DM. 2007. Determination of essential and toxic elements in Libyan foodstuff using instrumental neutron activation analysis (INAA). *J. Radioanal. Nucl. Chem.*, 271(1): 247-250.
- Celik U, Oehlerschlager J. 2007. High contents of cadmium, lead, zinc and copper in popular fishery products sold in Turkish supermarkets. *Food Control*, 18: 258-261.
- Doneley B. 2004. Treating liver disease in the avian patient. *Seminars in Avian and Exotic Pet Medicine*, 13: 8-15.
- Erdoğan Ö, Erbilir F. 2007. Heavy metal and trace elements in various fish samples from Sir Dam Lake, Kahramanmaraş, Turkey. *Environ. Monit. Assess.*, 130: 373-379.
- Falandysz J, Frankowska A, Mazur A. 2007. Mercury and its bioconcentration factors in King Bolete (*Boletus edulis*), *J. Environ. Sci. Health.*, Part A., 42A: 2089-2095.
- Gouda AA, Amin AS. 2014. Cloud-point extraction, preconcentration and spectrophotometric determination of trace quantities of copper in food, water and biological samples. *Spectrochim. Acta, Part A*, 120: 88-96.

- Institute of Medicine. 2003. Dietary reference intakes: applications in dietary planning. Subcommittee on interpretation and uses of dietary reference intakes and the standing committee on the scientific evaluation of dietary reference intakes. Institute of Medicine of the National Academies, The National Academies Press, Washington, DC, 248.
- Jalbani N, Kazi TG, Jamali MK, Arain MB, Afridi HI, Sheerazi ST, Ansari R. 2007. Application of fractional factorial design and doehlert matrix in the optimization of experimental variables associated with the ultrasonic-assisted acid digestion of chocolate samples for aluminum determination by atomic absorption spectrometry. *J. AOAC Int.*, 90: 1682-1688.
- Khan Md, Linkon MR, Satter MA, Jabin SA, Abedin N, Islam MF, Lisa LA, Paul DK. 2015. Mineral and Heavy Metal Contents of Some Vegetable Available In Local Market of Dhaka City in Bangladesh. *JESTFT*, 9(5): 1-6.
- Koréneková B, Skalická M, Na P. 2002. Concentration of some heavy metals in cattle reared in the vicinity of a metallurgic industry. *Veterinarski Arhiv*, 72 (5): 259-267.
- Kumar Singh R, Chavan SL, Sapkale PH. 2007. Heavy metal concentrations in water, sediments and body tissues of red worm (*Tubifex* spp.) collected from natural habitats in Mumbai, India. *Environ. Monit. Assess.*, 129: 471-481.
- Li S, Li L, Hao S, Wang Y, Zhang L, Liu S, Liu B, Kui L, Luo X. 2011. Dietary Manganese Modulates Expression of the Manganese-Containing Superoxide Dismutase Gene in Chickens. *J. Nutr.*, 141(2): 189-194.
- Munoz-Olivas R, Camara C. 2001. Speciation related to human health, in: Ebdon L, Pitts L, Cornelis R, Crews H, Donard OFX, Quevauviller P. (Eds.), Trace Element Speciation for Environment, Food and Health. The Royal Society of Chemistry, 331-353.
- Oyaro N, Juddy O, Murago EMM, Gitonga E. (2007). The contents of Pb, Cu, Zn and Cd in meat in Nairobi, Kenya. *JFAE*, 5(3-4): 119-121.
- Pouretedal HR, Rafat M. 2007. Simultaneous determination of nickel(II) and copper(II) by second-derivative spectrophotometric method in micellar media. *J. Chin. Chem. Soc.*, 54: 157-164.
- Sedki A, Lekouch N, Gamon S, Pineau A. (2003). Toxic and essential trace metals in muscle, liver and kidney of bovines from a polluted area of Morocco. *Sci. Total Environ.*, 317: 201-205.
- Shah AQ, Kazi TG, Baig JA, Afridi HI, Kandhro GA, Arain MB, Kolachi NF, Wadhwa SK. 2010. Total mercury determination in different tissues of broiler chicken by using cloud point extraction and cold vapor atomic absorption spectrometry. *Food Chem. Toxicol.*, 48(1): 65-69.
- Shah AQ, Kazi TG, Baig JA, Afridi HI, Kandhro GA, Khan S, Kolachi NF, Wadhwa SK. 2010. Determination of total mercury in chicken feed, its translocation to different tissues of chicken and their manure using cold vapour atomic absorption spectrometer. *Food Chem. Toxicol.*, 48(6): 1550-1554.
- Sipahi N, Mutlu C, Akkan T. 2013. Giresun ilinde tüketime sunulan bazı balıklardan izole edilen enterobacteriaceae üyelerinin antibiyotik ve ağır metal dirençlilik düzeyleri. *GIDA*, 38 (6): 343-349.
- Tuzen M. 2003. Determination of heavy metals in fish samples of the middle Black Sea (Turkey) by graphite furnace atomic absorption spectrometry. *Food Chem.*, 80(1): 119-123.
- Uluozlu OD, Tuzen M, Mendil D, Soylak M. 2009. Assessment of trace element contents of chicken products from turkey. *J. Hazard. Mater.*, 163: 982-987.
- World Health Organization. 1996. Trace Elements in Human Nutrition and Health. Geneva, 163-167.
- Yüzbaşı N, Sezgin E. 2002. Süt ve süt ürünlerindeki bazı metal kontaminantların toksikolojik etkileri. *GIDA*, 27(2): 211-127.