

GAZİ

JOURNAL OF ENGINEERING SCIENCES

Development of an Automatic PV-Battery Powered Water Irrigation System with Arduino Software for Agricultural Activities

Theodore Azemtsop Manfo^{a,b}, Mustafa Ergin Şahin^b

Submitted: 28.03.2024 Revised: 16.07.2024 Accepted: 17.07.2024 doi:10.30855/gmbd.0705A07

ABSTRACT

Irrigation is the artificial application of water to soil through tubes, pumps, and sprays, used when natural sources and rain are insufficient, irregular, dry, or drought-prone areas. This study proposes a drip irrigation-based solar-powered system for home grown plants and greenhouse gardens, utilizing solar energy for electricity consumption. The system is highly efficient for providing water and nutrients to crops, ensuring optimal growth, and conserving resources like water, fertilizers, energy, and crop protection products. A water tank uses an Arduino ATmega328 microprocessor to detect plant moisture levels and supply water to plants through a water motor and sensor. The system employs drip irrigation to pump water through pipes using a DC motor. The automated irrigation system utilizes a boost DC-DC switching converter, to step up input voltage and increase the output voltage, enabling remote monitoring of humidity, water, and energy consumption in flowerpots. The converter achieves significant step-up voltage gain with a suitable duty ratio and minimal voltage stress on the power switches. It is an off-grid automatic control system that operates independently of human intervention. The system utilizes a boost converter to indirectly optimize the power of two series-connected PV cells, increasing overall efficiency.

Keywords: Irrigation system, Energy efficiency, DC-DC boost converter, Automatic Control, Solar cell, PV, MATLAB/Simulink

^aUniversity of Vaasa,
School of Technology and
Innovations, Dept. of Electrical
Engineering,
65200 Vaasa, Finland
Orcid: 0000-0002-9043-3111

^bRecep Tayyip Erdoğan University,
Faculty of Engineering and
Architecture,
Dept. of Electrical and Electronics
Engineering, 53100 Rize, Türkiye
Orcid: 0000-0002-5121-6173

*Corresponding author:
azemsouleymane@yahoo.fr

Tarımsal Faaliyetlere Yönelik Arduino Yazılımı ile Otomatik PV ve Akü ile Beslenen Su Sulama Sisteminin Geliştirilmesi

ÖZ

Sulama, doğal kaynakların ve yağmurun yetersiz olduğu, düzensiz, kuru veya kuraklığa yatkın bölgelerde kullanılan suyun tüpler, pompalar ve spreylere aracılığıyla toprağa yapay olarak uygulanmasıdır. Bu çalışma, evde yetiştirilen bitkiler ve sera bahçeleri için elektrik tüketimi için güneş enerjisinden yararlanan, damla sulama bazlı güneş enerjisiyle çalışan bir sistem önermektedir. Sistem, mahsullere su ve besin sağlamak, optimum büyümeyi sağlamak ve su, gübre, enerji ve bitki koruma ürünleri gibi kaynakları korumak için oldukça verimlidir. Bir su deposu, bitki nem seviyelerini tespit etmek ve bir su motoru ve sensör aracılığıyla bitkilere su sağlamak için bir Arduino ATmega328 mikroişlemcisini kullanmaktadır. Sistem, bir DC motor kullanarak borulardan su pompalamak için damlama sulama yöntemini kullanmaktadır. Otomatik sulama sistemi, giriş voltajını yükseltmek ve çıkış voltajını artırmak için bir DC-DC anahtarlama dönüştürücüsünü kullanır ve saksılardaki nem, su ve enerji tüketiminin uzaktan izlenmesine olanak tanır. Dönüştürücü, uygun bir görev oranı ve güç anahtarları üzerindeki minimum voltaj stresi ile önemli miktarda artan voltaj kazancı elde etmektedir. Şebekeden bağımsız, insan müdahalesinden bağımsız çalışan otomatik kontrol sistemidir. Sistem, seri bağlı iki PV hücresinin gücünü dolaylı olarak optimize etmek ve genel verimliliği artırmak için bir destek dönüştürücü kullanmaktadır.

Anahtar Kelimeler: Sulama sistemi, Enerji verimliliği, DC-DC yükseltici dönüştürücü, Otomatik kontrol, Güneş pili, PV, MATLAB/Simulink

1. Introduction

Irrigation is the artificial application of water to the soil using various technologies such as pumps, tubes, and sprays. Irrigation is usually necessary in locations with irregular rainfall, during dry spells, or where dehydration is widespread [1]. Water for irrigation comes from various sources, including underground water from wells or springs, surface water from lakes and rivers, and water from other sources, such as treated wastewater or desalinated seawater [2]. There are two sorts of current irrigation techniques: traditional irrigation methodologies and intelligent irrigation methodologies. Traditional irrigation systems include surface, drip, and sprinkler irrigation [3]. Irrigation planning takes into account when and how much water should be applied to plants [4]. The management practices with the greatest impact are determined by the kind and design of the irrigation system. Several well-known challenges impact how far the irrigation system succeeds, such as determining when to irrigate the land, the appropriate amount of water, and the ability to improve efficiency [5].

Energy supply is a critical component in the growth of any society [6-8]. Today, the fast-expanding energy demand needs a restricted usage of fossil fuels [9]. The sun, our everlasting power source, continues to heat and illuminate our world on the other side [10]. Solar energy is a popular and cost-effective renewable energy source. The amount of energy produced by solar cells is significantly influenced by weather and solar radiation [11]. Renewable energy sources and their application have become increasingly vital to humanity over the last few decades [12]. Photovoltaic generating, among renewable energies, is a particularly promising technology for electrical energy production because of its environmentally favorable and flexible operation [13]. Many architects, designers, and manufacturers throughout the world are looking into photovoltaics (PV) as a long-term energy source [14]. The smart irrigation system is made up of several technologies, including battery and sensor, automatic control, and computer technology. Researchers are paying a lot of attention to the rapid development of Li-ion battery technology [15]. Sustainable energy sources fluctuate throughout the day, necessitating the use of suitable energy storage technology like batteries for electricity production [16]. Conventional energy storage systems like batteries face challenges like drowsy charging and limited lifespan [17]. PV systems use batteries to store excess energy, a growing concern due to increasing energy consumption [18]. Automation and control systems are crucial for facilitating lives. Water needs for plants are influenced by factors like rain, temperature, and wind, making efficient use of agricultural water increasingly important [19].

Proper irrigation systems in agriculture are essential for yield and water scarcity, with traditional drip irrigation reducing soil humidity stress but applying undetermined amounts of water. Occasionally, an excessive amount of water is continuously delivered to the crop, and sometimes too little water is given to the crop, defeating the system's purpose [20]. One main reason for this is the wasteful waste of water in agricultural areas due to farmers' lack of knowledge about a sufficient supply of water [21]. Many plants are extremely sensitive to water levels and require a precise level of water supply for healthy growth; if this is not met, they may die or grow improperly. Stock farming is an integral part of Turkish agriculture and many farmers are interested in earning money with meat, milk, and wool [22]. A large proportion of freshwater resources are used for agricultural irrigation, both in Türkiye and around the world [23]. In total, 280 million hectares of agricultural land are irrigated, which represents 19% of all agricultural land in the world [24]. Developing countries' agriculture economy faces underutilization due to erratic water use, necessitating the implementation of automatic irrigation systems despite modern techniques like drip and sprinkler irrigation. Many strategies used in autonomous irrigation systems are detailed in the literature [25-27]. A microcontroller-based system automates irrigation for small potted plants, improving efficiency and reducing manual intervention in agriculture during scarce water. A system was developed that detects temperature and humidity changes in the environment using sensors and controls the pump via a signal sent by the microcontroller [28]. The planned system was reported to be cost-effective and enabled farmers to irrigate overnight without the need for physical presence. Taneja and Bhatia created a new autonomous watering system to save water by combining sensor technology with Arduino [29]. The irrigation network employs a

dual-tone multi-frequency signaling (DTMF) management system, enabling precise irrigation, spraying, and parameters via phone commands, minimizing user-requested cessation. A DTMF decoder and controlling circuit decodes and controls the on-off mode of the associated electrical motor pump [30]. The study examines the use of photovoltaic-assisted pumping elements in agricultural regions, analyzing water movement based on dynamic heights and variable water values. As a result of the design, a lifetime cost analysis for the required height and water amount is performed [31].

Research suggests an embedded technology for remote greenhouse inspection, offering a low-cost online greenhouse automation design. The temperature and soil moisture levels in a greenhouse region are measured using a real-time greenhouse automation system, the design variables are checked against the recorded values, and the collected data is transferred to an embedded web interface for users to view [32].

The automation systems used in greenhouses can be analyzed in two sections; namely, climate control and the automation of irrigation-fertilization. These systems cover expert systems that generally involve backwards-feeding or forward-feeding methods [33]. In backward-feeding systems, after the variable is perceived, the control system is activated while in forward-feeding systems the tendency of change of the variable is predicted initially and after that, the control system reacts to the relevant tendency [34-36]. All these processes are conducted by a computer unit which is the brain of the automation where the relevant programs are loaded.

Barkunan et al. transformed a drip irrigation system into a smart system using a microcontroller, GSM, sensors, motor, and telephone module, resulting in 41.43% savings compared to the drip irrigation system [37]. The study by Küçüksayan analyzes the variation in irrigation applications across different landscape regions in Ankara district. It reveals that design, construction, scheme, and maintenance methods vary based on the installation, system, and planning. The chosen irrigation design can enhance water usage and prolong the life of green parts [38].

The smart irrigation system, as depicted in Figure 1, integrates data acquisition, control, wireless communication, processing, and problem detection, all of which can be integrated into IoT devices.

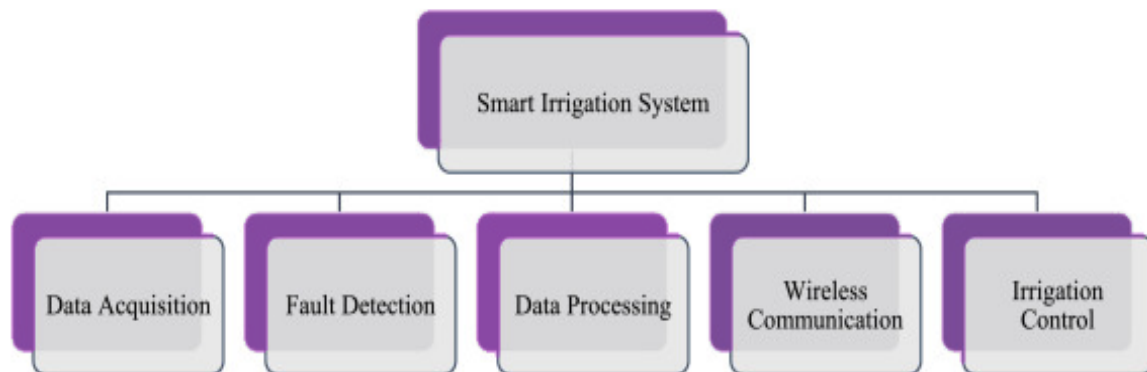

Figure 1. Smart irrigation system components [39].

This technology can be adopted on a wide scale for farming reasons, making it much more beneficial. Due to current conditions and water scarcity, optimal irrigation schedules should be devised, particularly in farms, to conserve water.

The main idea is to design a cost-effective irrigation system that uses less electrical energy and water which can be used for the growth of various crops compared to other systems, such as the sprinkler irrigation studied by Yavuz et al. [40], which requires significant energy consumption. A previous study also found that the irrigation system consumed 76% of the total energy input in alfalfa production [41]. Water application methods that use ancient groundwater resources and groundwater extraction were mentioned as reasons for the high consumption of electrical energy in the study region [41]. Furthermore, Khan et al. [42] examined

energy inputs under different irrigation systems in Australia for the production of wheat, rice, and barley. To reduce the environmental footprint of water and energy inputs, the authors recommend improving energy efficiency and water productivity of crop production.

This work presents an automatic irrigation system that will save more electricity, and water, and increase the yield of the plant automatically compared to aforementioned systems. The system is tested using solar panel electricity that improves its outputs, controls the water supply, reduces employee workload, and addresses soil conditions. The Arduino platform controls a water motor and humidity sensor, ensuring optimal operation for plant maintenance. The ATmega328 microprocessor detects moisture levels, allowing water to be pumped. The Arduino triggers when soil moisture decreases, implementing a drip irrigation method. This smart automated drip irrigation system offers a more practical and economical method to uniformly distribute water to plants at small and/or large-scale surface areas while saving water and energy. The automated irrigation system compared to other systems is designed for various plants including vegetables and many fruits and was tested on agricultural land. The system uses energy from PV solar cells and a battery to reduce water consumption and improve plant productivity. It features durable Epoxy solar panels, thermal management products, a DC/DC power converter, a Micro DC 3-6V Submersible Pump, and a humidity sensor for measuring soil moisture. The drip irrigation method uses a DC motor to pump water through pipes, detects soil moisture, and processes data using a microcontroller. The motor is automatically started based on sensor data. The automated system is designed for various plants including vegetables and fruits, and was tested on agricultural land. The controllers can be programmed to open the valves and begin irrigation when the volumetric water content reaches a predetermined threshold. The suitable threshold value varies by soil and vegetation type and ranges from 10 to 40%. The hybrid irrigation system was found to be environmentally friendly and suitable for use in areas without electricity, as the energy was met by the 3 V PV cells combined with a relay with a 6 V, 2 Ah Lithium-ion battery. This innovative approach to irrigation has the potential to revolutionize agricultural practices. It was found that the developed automation-based irrigation system could prevent human errors while saving labor and time. The studies also have proven this hybrid system of irrigation improved product yield and quality. The smart irrigation systems integrates PV-Battery to improve water-use efficiency for sustainable agriculture. It describes how Arduino UNO and sensory systems efficiently monitor soil conditions, optimize irrigation, and save water using various sensors. The article highlights the importance of modernizing agricultural techniques, presenting a user-friendly automated irrigation system that enhances efficiency, data collection, and resource conservation by automating tasks like watering and temperature control. First, it is a multidisciplinary study involving Agriculture, Software Engineering, and Electronic Engineering. Furthermore, this is an automatic control system that operates independently of the grid and functions without human intervention. By using a boost converter, it regulates the power of two series of PV cells indirectly at the maximum power point to enhance the efficiency of this system.

2. Materials and Method

2.1. Process description

The setup of the automatic irrigation system was designed as shown in Figure 4 and the elements are explained in the following sections. Solar panels supply the necessary electrical energy for the self-contained irrigation system. The drip irrigation method is designed to implement the irrigation process by pumping the water in the tank through the pipes using a DC motor. The system detects soil moisture and processes the data acquired by the sensor using a microcontroller, and the process is carried out by turning the DC motor on and off for a certain amount of time. The irrigation operation is started automatically by starting the motor based on data from the soil moisture sensor. When the volume of water reaches a set level, the engine is turned off, and the watering cycle is repeated at certain humidity intervals. The water level sensor controls the amount of water in the tank. When the tank's water level reaches a predetermined level, a network-connected solenoid valve opens, allowing the filling process to commence. When the tank's water level reaches a preset level, the valve

is closed by sensing the water level sensor. The automatic irrigation system consists of a soil moisture sensor, an Arduino Uno, a solar panel, a charge management circuit, a DC motor, a solenoid valve, and a water level sensor. This study aims to meet the electricity needs of the system with the help of solar panels. The specifications of the PV panel, Submersible Mini DC Water Pump, and Soil Moisture Sensor are given in Table 1.

The soil moisture sensor for Arduino is a compact, user-friendly sensor that measures soil moisture using two probes. It is designed for Arduino microcontroller boards, allowing easy connection to an analog or digital input pin for programming purposes. Probes that measure humidity values are immersed in the soil to be measured during the measurement process. The sensor's reading indicates soil type, with values above 1000 indicating detached or uninhabitable soil, below 600 indicating dry or humid soil, and below 370 indicating water presence. This irrigation system based on soil moisture was developed to be used for different plants such as tomatoes, peanuts, soybeans, Strawberries, Chilli, Capsicum, Cabbage, Cauliflower, Onion, Okra, Brinjal, Bitter Gourd, Ridge Gourd, Cucumber, Peas, Spinach, and pumpkin.

Table 1. The specifications of the PV panel, mini DC water pump, soil moisture sensor, and DC-DC boost converter

Type	Parameters	Values
Solar Panel	Power	3W
	Size	145×145mm
	Output voltage	12V
	Open circuit voltage	13.2V
Submersible Mini DC Water Pump	Operating Voltage	3 ~ 6V
	Operating Current	130 ~ 220mA
	Flow Rate	80 ~ 120 L/H
	Maximum Lift	40 ~ 110 mm
	Continuous Working Life	500 hours
	Driving Mode	DC, Magnetic Driving
	Material	Engineering Plastic
	Outlet Outside Diameter	7.5mm
	Outlet Inside Diameter	5 mm
	Operating Voltage	3 ~ 6V
Operating Current	130 ~ 220mA	
Soil Moisture Sensor	Operating voltage	3.3V to 5V
	Operating current	20 mA
	Output	Analog & Digital
	Dimensions	20mm×15mm×10mm
DC-DC boost converter	Weight	10g
	Input voltage	12V (9V-22V)
	Output voltage	24V
	Output current (max)	4A
	Output power	96W
	Conversion efficiency	up to 90%
	Soft start time	500mS
	Output ripple	80mV (MAX)
	Dynamic response rate	5% 200uS
	Protection class	IP67
Size	58x40x22mm	

2.2 Experimental set-up of the irrigation system

The DC-DC boost converter helps to increase or decrease a direct current (DC) source from any voltage level to another DC voltage level. The major advantages is that this irrigation system minimizes energy losses and high efficiency. Figure 2 shows the entire automated hybrid energy source irrigation system. Figure 2 (a) depicts a functional block diagram of the system and the complete setup with test procedures and measurements as shown in Figure 2 (b).

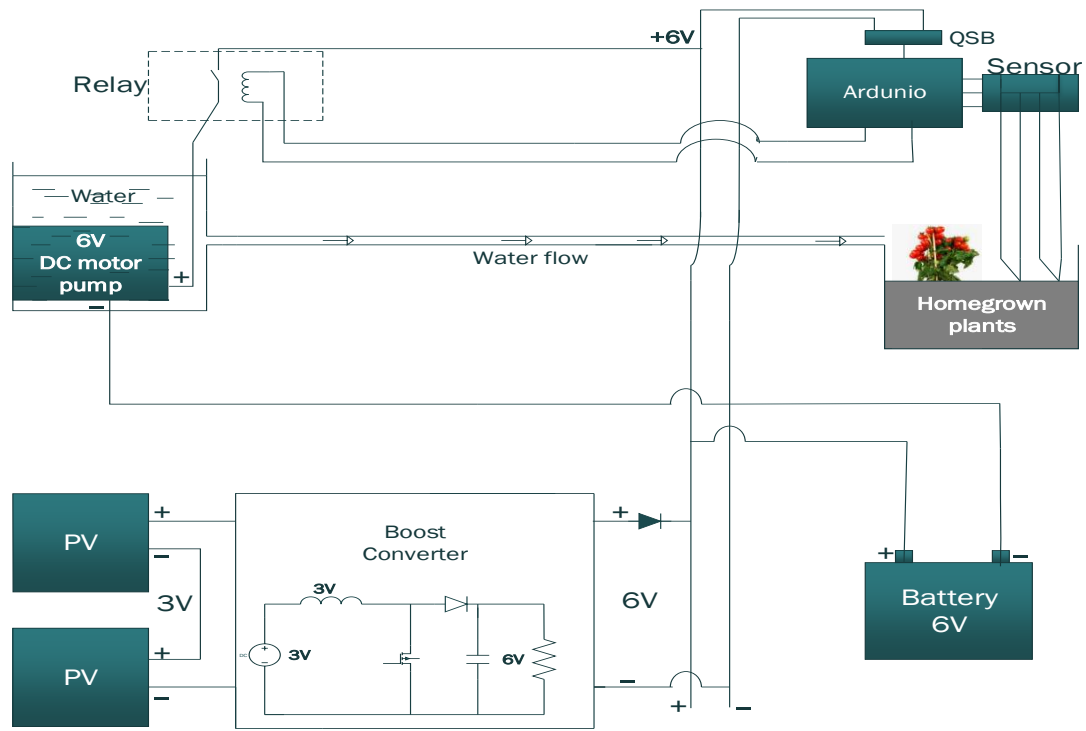

(a)

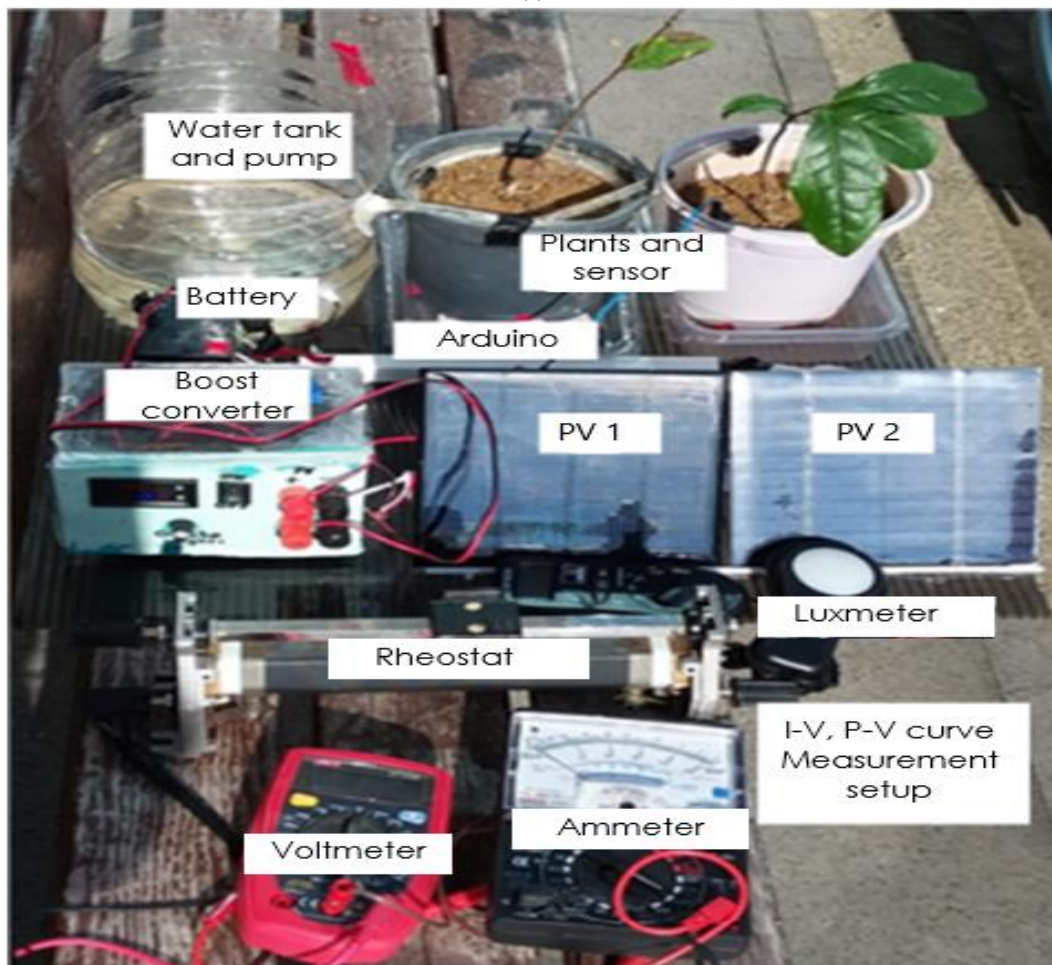

(b)

Figure 2. Automated hybrid energy source irrigation system, (a) The water irrigation system's block diagram, (b) Experimental design and test setup.

3. Results and Discussions

3.1. Simulations results

The boost converter simulation circuit of the DC-DC response is shown in Figure 3. A boost converter is a DC/DC power converter that increases the voltage from the source to the load. The duty cycle formula needed to increase the voltage value at the system's output to the target voltage is shown below. The theoretical transfer function of the boost converter is given by Equation (1) where D is the duty cycle:

$$\frac{V_{out}}{V_{in}} = \frac{1}{1-D} \quad (1)$$

In this case, the converter is supplying an RC load from a 20 V supply, and the PWM frequency is set to 20 kHz. Run the simulation and look at the waveforms with Scope. Ascertain that the mean value of the load voltage (V_{out}) is extremely near to the theoretical value of:

$$V_{out} = \frac{V_{in}}{(1-D)} = \frac{20}{(1-0.5)} = 40 \text{ V} \quad (2)$$

In Figure 3, when the MOSFET is at cut-off, the energy stored on the inductor flows through the load (R), capacitor (C), and diode. In this case:

$$\frac{di_L}{dt} = \frac{V_{in}}{L} \quad (3)$$

$$\frac{dV_C}{dt} = -\frac{V_{out}}{RC} \quad (4)$$

Considering the equality between equations (3), (4), (5), and (6), the result is as follows:

$$\frac{di_L}{dt} = \frac{V_{in}}{L} D + \frac{V_C}{L} (1-D) \quad (5)$$

$$\frac{dV_C}{dt} = -(1-D) \frac{i_L}{C} - \frac{V_C}{RC} \quad (6)$$

The inductance of the coil (L) in the design is given in the equation (7):

$$L = \frac{R(1-D)^2}{2f} D \quad (7)$$

The circuit can convert a DC voltage to a higher DC voltage. DC-DC converters operate on a coil and capacitor basis.

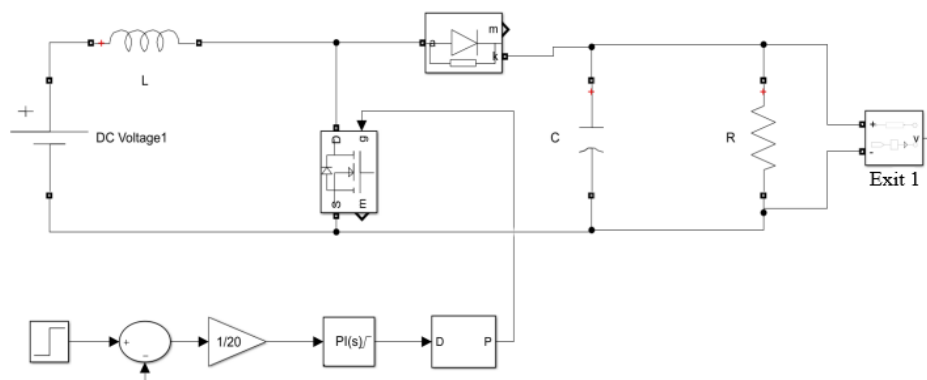

Figure 3. DC-DC boost converter simulation circuit.

When a voltage of 10 V is applied to the input, the voltage at the output becomes 20 V. A voltage of 20 V is utilized as a reference as shown in Figure 4. In this design, a MOSFET is used for switching. As it turns off and on, DC power is stored on the coil, and as the cycle repeats, it is transferred to the capacitor via the coil each time. It continues until the voltage across the capacitor reaches its maximum value.

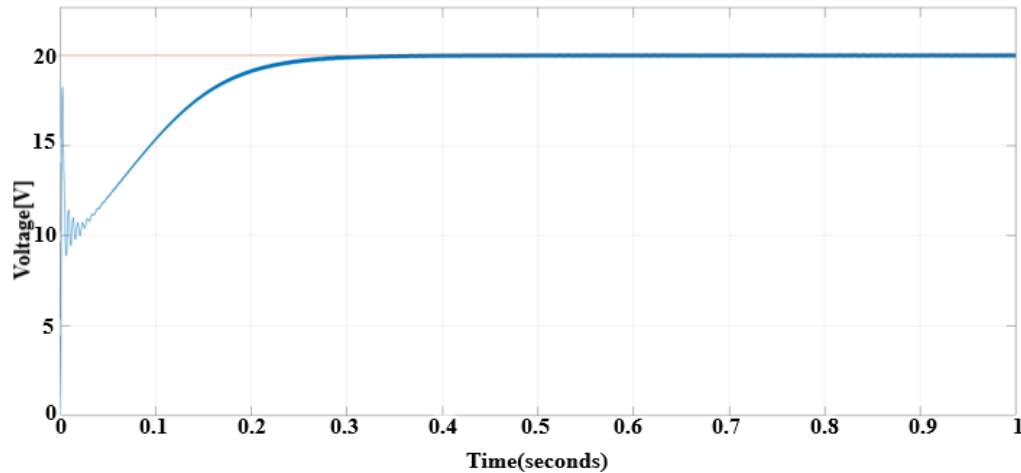

Figure 4. The 20 V reference voltage output signal variation with time.

The step signal is referenced as a minimum of 12 V and a maximum of 24 V of the system. A constant voltage of 5 V is supplied to its input. After a certain period of fluctuations when the system is started caught the tension. It is seen as 12 V and 24 V as output as shown in Figure 5. The output voltage is determined by the coil rating, capacitor rating, and duty cycle of the MOSFET. The system requires increasing the voltage value at the output to the desired voltage.

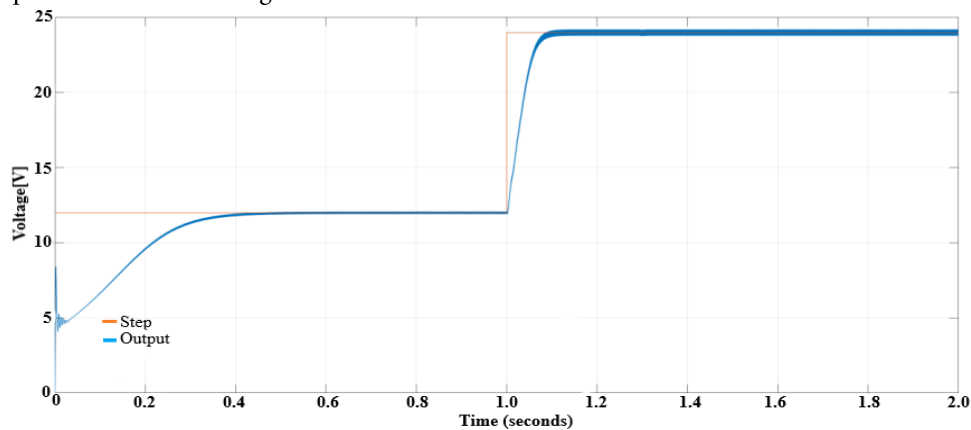

Figure 5. Output signal with step response.

When the inductance value is 47 μH , the current passes over the coil on the system and it has been observed that the coil works intermittently as shown in Figure 6. A minimum voltage of 12 V and a maximum voltage of 24 V were used as references. The Inductance voltage demonstrates a discontinuity mode over time. When the power supply is shut off, the magnetic field collapses and all current in the coil flows to the capacitor.

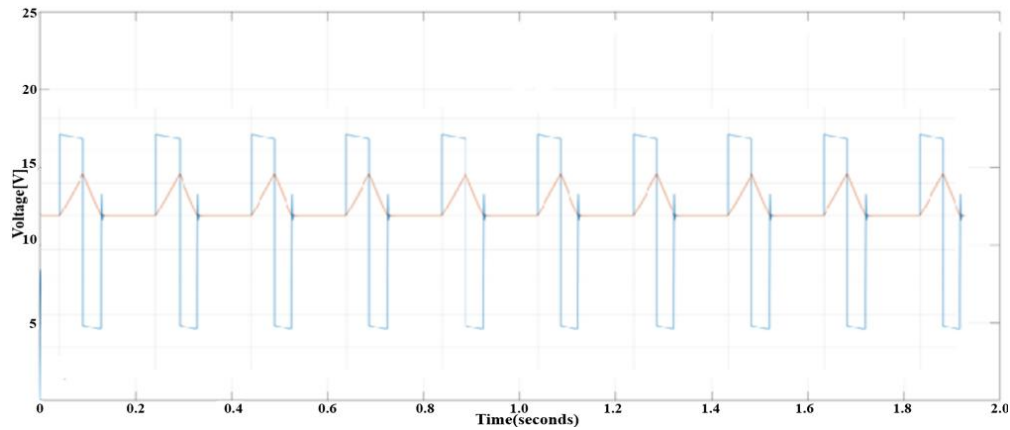

Figure 6. Inductance voltage and current pulsed operation signals.

The applied voltage enables the coil to store the current drawn. A magnetic field is formed on the coil while the power source is turned on. When the coil value in the system is $4700 \mu\text{H}$, the fluctuation on the coil is shown in Figure 7. The parameter values of the designed system are given in Table 2.

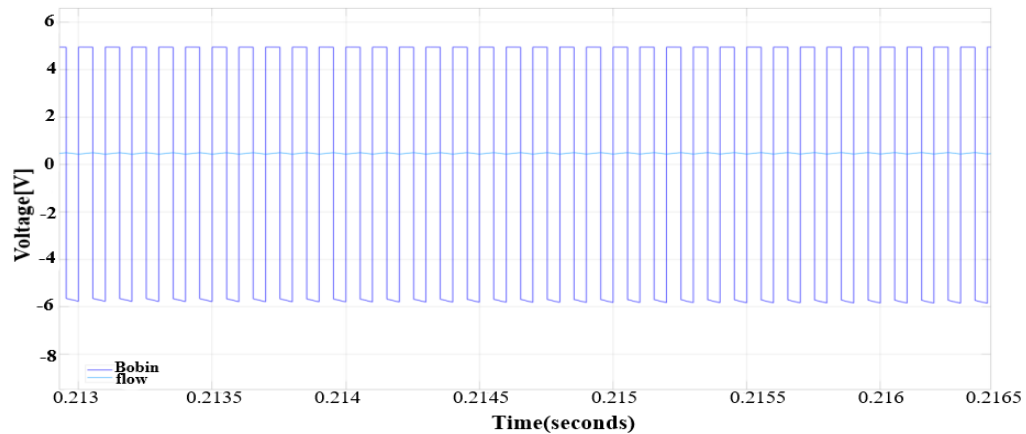

Figure 7. Inductance current and voltage signals for continuous mode.

Table 2. Simulation parameters of the designed system.

Parameters	Values
Input Voltage (V_g)	$V_g = 5 \text{ V}, 10 \text{ V}$
Output Voltage (V_{out})	$V_{out} = 12 \text{ V}, 20 \text{ V}, 24 \text{ V}$
Load	$R = 24\Omega, 47\Omega$
Output Reference Voltage	$V_r = 12 \text{ V}, 24 \text{ V}$
Coil Value (L)	$L = 470 \mu\text{H}$
Capacitor Rating (C)	$C = 100\mu\text{F}$
Switching Element	MOSFET
Rectifier Element	Power Diode
Controller Parameters (PI)	$K_p = 0.01, K_i = 5$

3.2. Experimental results

The DC-DC boost converter circuit was designed and tested. The DC-DC converter circuit was manufactured to be transparent and not be affected by any external factors. On the front side of the box, the voltage adjustment pot, the input and output terminals of the solar panel, and the input and output locations of the

loads to be supplied were made. Several simulations and circuit analysis programs were used to construct and test the boost converter circuit on the board. The power supply's input voltage was 6 V. This voltage was changed using a potentiometer and was raised to a voltage of 10 Volts. A USB connection was built to the computer to measure the pulse with modulation (PWM) signal, coil current, and output voltage signals. The signals were measured using a computer oscilloscope.

A digital voltmeter was mounted on the front side to measure the current flowing through the circuit and the load voltage. To increase the robustness of the box, the perimeter of the box was supported with silicone. The calibrated DC-DC converter solar panel was then tested in a suitable environment and the completed circuit was designed. A load was connected to a circuit, and the current was calibrated using a digital voltmeter. The circuit current was set to 0 A when no load was present and adjusted when a load was connected. The system was powered by solar panel electricity instead of a voltage source. The boost converter increased the electricity above 24 V without a load.

The data of the I-V and P-V characteristics of the solar cells connected serially shown in Figure 8 are obtained using the complete circuit design in Figure 8(b). The error analysis was conducted and showed the error limits in both figures as error bars with the default of 5% value. The I-V curve of the solar cell shows that the open circuit voltage of the PV cells is 27 V and the short circuit of the PV cells is 190 mA as shown in Figure 8(a). The P-V curve of the solar cell shows a 3-watt maximum power for 20 V as shown in Figure 8(b). This nonlinear voltage is converted to a suitable voltage to charge the 6 V nominal voltage battery. Also, these curves show that the PV cells with the converter charge the battery during the 4 hours and can charge the 6 V, 2 Ah current battery safely. If the battery is fully charged it can supply the system for a long time without solar energy.

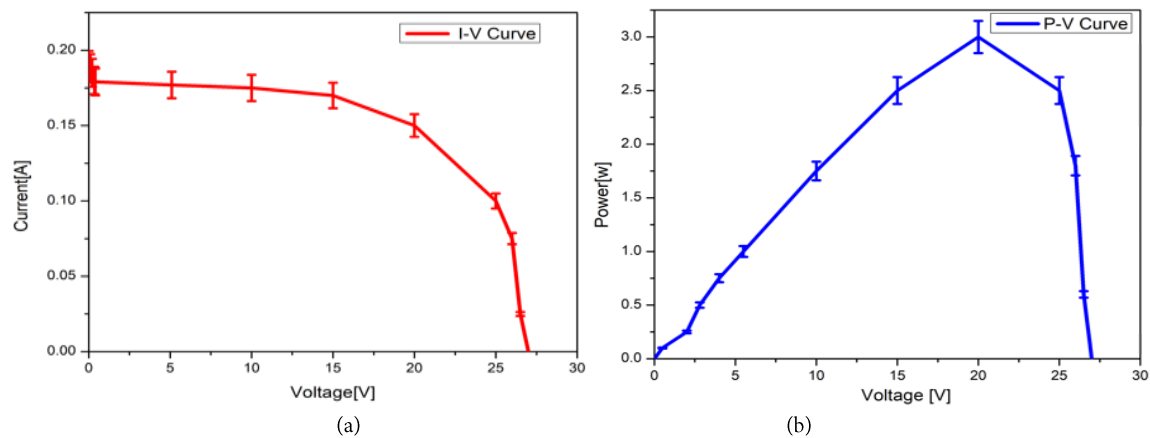

Figure 8. Solar Cell characteristics. (a) I-V curve of PV cells, (b) P-V curves of PV cells.

3.2.1. Arduino IDE software

The Arduino Uno driver must be manually loaded on your PC via the device manager first. The virtual serial port number to which the Arduino is connected will be displayed after installing the driver. The program was designed in C language using the Arduino IDE software. The Arduino Uno is a microcontroller based on the datasheet for the ATmega328. It has 14 digital inputs and output pins, including 6 pins PWM output and 6 pins clock speed of 16 MHz, a ceramic resonator USB connector, a power jack, an analog input such as a spreader, and a reset button [43]. It is an open-source microcontroller that is used to control the relay; to begin, simply connect it to a computer via USB or power it with an AC-to-DC rectifier or battery. It includes many libraries for interacting with a wide range of devices. The FTDI USB-to-serial driver chip is absent from the Uno, as is the case with all previous boards. Because the operational numbers on the motor nameplate range from 5-12 V and 150-300 mA, the input voltage is adjusted to 6 V. The SVR-5 relay is connected between the power source and the motor to regulate the current flowing through it. The Arduino program was opened and the codes were written for the coordinated operation of the sensor and motor on Arduino

software as follows;

Code:

```
int sensorPin = 9; // Sensor pin
int buzzerPin = 8; //Motor pin
int data; // Humidity sensor reading value
void setup() {
  Pinmode (sensorPin, INPUT); // Sensor pin input
  Pinmode (rolePIN, OUTPUT); // Motor pin input.
}
void loop() {
  Data = digitalRead(sensorPin); // Humidity sensor value
  If (data ==True) { // If the humidity value is above the limit
  Digitalwrite (buzzerPIN, OPEN);
  delay(3000);
  Digitalwrite (rolePIN, CLOSE);
  delay(3000);
  }
  Else { // If the humidity value is below the limit
  Digitalwrite (rolePIN, OPEN);
  }
}
```

The water engine is responsible for pumping water through pipes at a specific rate. The water motor in the design works for a set length of time as the soil moisture sensor value and signal it delivers diminish. Figure 9 depicts the details of the Arduino pin for hardware connection.

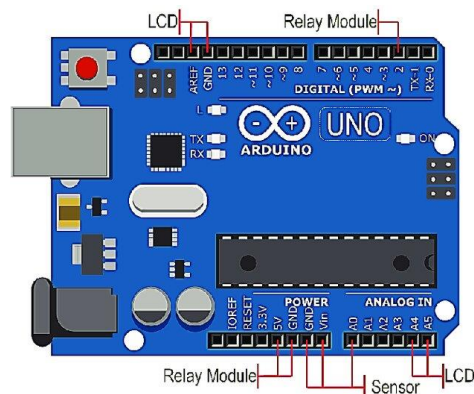

Figure 9. Details of Arduino pin for hardware connection [44].

Figure 9 displays the Arduino pins and their hardware connections. The automated function is comprised of two primary pieces of controlling hardware: the relay module and the DC watering pump. The relay is an autonomous electric switch that uses an electromagnet to change the switch from OFF to ON or vice versa. The switch regulates the electric signal sent to the water pump. When the moisture level falls below the threshold, Arduino sends a signal to the relay module, which immediately opens the way for electricity to run through the water pump and water the plant. When the system detects a suitable level of water in the soil, the relay closes the path for power, and the water pump immediately stops pumping water. All of the hardware will be assembled into Arduino, a microcontroller that will control all of the hardware attached to it and allow it to function. This project is regarded as a finished prototype that can be utilized and function in everyday life. The Arduino serves as the system's nerve center, connecting all necessary components. The soil moisture sensor, which is attached to the Arduino pins (A0, Vin, GND), measures the moisture level in the soil and delivers it to the Arduino board for processing and decision-making. The Arduino LCD panel (A4, A5, AREF,

GND) displays the value obtained from the moisture sensor. Simultaneously, the acquired data is delivered to the relay module, which determines whether to turn on or off the water pump. Simultaneously, the acquired data is transferred to the relay module coupled with Arduino (5V, GND, 2) to determine whether to turn on or off the water pump.

3.2.2. Motor, and sensor connection stages

The water motor is powered by a 3 V DC voltage. The system employs one relay. With the soil moisture sensor signal, 3V DC is sent to the motor, current flows via the relay connections, and water begins to be pumped. After the given time, the contacts' positions become open, and the motor's energy is cut off. 5 V input voltage was applied to the Arduino input. The humidity sensor was connected to the Arduino for testing. Pin 9 on the Arduino was connected to the sensor. The trigger pin of the Arduino was set to the 8th pin of the Arduino and the output was received. When the soil moisture value decreases, the Arduino is triggered and signaled by the sensor. When the humidity sensor is logic 0, the Arduino starts the motor. The running time of the motor is set to 2 seconds. The connection of the soil moisture sensor with Arduino is given in Figure 10.

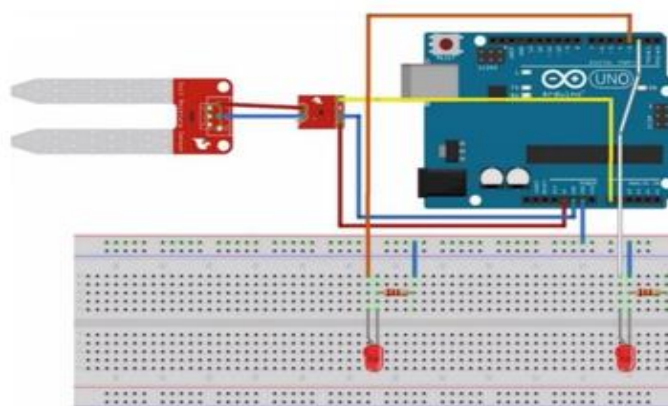

Figure 10. Connections of soil moisture sensor with Arduino

Table 3. The comparison of the threshold high temperature measured for major crops at different stages of development.

Crop	Threshold temperature (°C)	Growth Stage
Cool season pluses	25	Flowering
Wheat	26	Post anthesis
Brassica	29	Flowering
Tomato	30	Emergence
Groundnut	34	Pollen production
Rice	34	Grain yield
Pear Millet	35	Seedling
Corn	38	Grain filling
Cowpea	41	Flowering
Cotton	45	Reproductive

Since the operating values on the motor label are 5-12 V and 150-300 mA, the input voltage was set to 6 V. To keep the current coming to the motor under control, the SVR-5 relay was connected between the power supply and the motor. After finishing all the settings, a soil moisture sensor was inserted into the pot. Water pump motors were placed in the water supply. Soil with a low moisture value was preferred for observational purposes. Due to the low humidity value, it was seen that the motor pumped water for a given period with the signal supplied by the humidity sensor to Arduino Uno, and the plant was irrigated in the pot using the drip irrigation method so that the plant would not be damaged. The suitable threshold value varies by soil and vegetable. Table 3 shows the comparison of the threshold high temperature for the used crops at

different stages of development.

4. Conclusion

This study conserved electricity, and water from plants, and investigated healthy watering methods. The plant is irrigated by drip irrigation based on literature research. Data obtained during the design phase was compared with findings obtained during the application phase. The design of the solar panel was tested in various ways to obtain energy. The system utilized solar energy, a humidity sensor, Arduino, and a water pump motor to control the plant's water needs. The system aimed to save electricity, and water, and automatically control the irrigation process, ultimately increasing plant productivity. The system uses an inverter to convert solar energy into DC voltage, controlling water requirements with a humidity sensor, and a motor to meet water requirements, aiming to save electricity and water. The Arduino-based autonomous irrigation system combining PV solar panels and batteries, offers a sustainable, accurate, and efficient method for irrigation, reducing manual labor and improving resource efficiency, while also reusing excess energy for reuse. The I-V and P-V curves of solar cells connected serially show an open circuit voltage of 27 V and a short circuit current of 190 mA. The P-V curve reveals a maximum power of 3 watts at 20 V, which is enough to charge a 6V, 2 Ah current battery for four hours. The design enables remote monitoring of humidity, water, and energy usage in flowerpots, making it suited for agricultural applications such as greenhouses and farms. The agriculture-specific sustainable irrigation system has been tested on a variety of crops, including tomatoes, peanuts, soybeans, strawberries, and more. Additional sensors can be added to monitor temperature and pressure, which will be subject to further investigations.

Acknowledgment

The authors thank Ömer Gökçeoğlu, Selahattin Doğruyol and Dr. Yasin Karan for their contributions to this study.

Conflict of Interest Statement

The authors declare that there is no conflict of interest.

References

- [1] G. J. Hoffman, R. G. Evans, M. E. Jensen, D. L. Martin, and R. L. Elliott, *Design and operation of farm irrigation systems*. American Society of Agricultural and Biological Engineers. St. Joseph, Michigan, 2007.
- [2] W. R. Walker, *Food and Agriculture Organization of the United Nations*. Guidelines for designing and evaluating surface irrigation systems, Food and Agriculture Organization of the United Nations, Rome, 1989.
- [3] Y. Gamal, A. Soltan, L. A. Said, A. H. Madian, A. G. Radwan, "Smart Irrigation Systems: Overview," *IEEE Access*, vol.4, pp.99, January 2023. Doi:10.1109/ACCESS.2023.3251655
- [4] S. L. Davis, M. D. Dukes, "Irrigation scheduling performance by evapotranspiration-based controllers," *Agricultural Water Management*, vol. 98, pp. 19-28, December 2010. Doi:10.1016/j.agwat.2010.07.006
- [5] I. Kisekka, K. W. Migliaccio, M. D. Dukes, B. Schaffer, J.H. Crane, H. K. Bayabil, S.M. Guzman, "Evapotranspiration-Based Irrigation for Agriculture: Sources of Evapotranspiration data for Irrigation Scheduling in Florida, *EDIS*, April 2010. Doi:10.32473/edis-ae455-2010
- [6] T. A. Manfo, A. A. Abdullahi, S. D. Pawan, "Effect of Layered, Spinel, and Olivine-Based Positive Electrode Materials on Rechargeable Lithium-Ion Batteries: A Review," *Journal of Computational Mechanics, Power System, and Control*, vol. 6, pp. 38-57, November 2023. Doi:10.46253/jcmps.v6i4.a4
- [7] T. A. Manfo, "Progress into lithium-ion battery research," *Journal of Chemical Research*, vol. 47, no. 3, pp. 1-9, 2023. Doi:10.1177/17475198231183349

- [8] T. A. Manfo, S. Konwar, P. K. Singh, R.M. Mehra, Y. Kumar, M. Gupta, "PEO + NaSCN and ionic liquid-based polymer electrolyte for supercapacitor," *Mater. Today: Proc.*, vol. 34, pp. 802-812, June 2020. Doi:10.1016/j.matpr.2020.05.340
- [9] M. E. Şahin, H. İ. Okumuş, "Modeling and simulation of solar cell module with Matlab/Simulink," *EMO Scientific Journal*, vol. 3, no. 5, June 2013.
- [10] M. E. Şahin, "A photovoltaic powered electrolysis converter system with maximum power point tracking control," *International Journal of Hydrogen Energy*, vol. 45, no:16 pp.9293-9304, March 2020. Doi: 10.1016/j.ijhydene.2020.01.162
- [11] M. E. Şahin, "Energy Management and Measurement of Computer Controlled Solar House Model for Rize City," *Gümüşhane Üniversitesi Fen Bilimleri Dergisi*, vol.10, no: 2, pp.404-414, 2020. Doi: 10.17714/gumusfenbil.544087
- [12] M. E. Şahin, H. İ. Okumuş, "Parallel-connected buck-boost converter with FLC for hybrid energy system," *Electric Power Components and Systems*, vol. 48, no:19-20, pp. 2117-2129, 2021. Doi: 10.1080/15325008.2021.1913261
- [13] M. E. Şahin, H. İ. Okumuş, "Physical Structure, Electrical Design, Mathematical Modeling and Simulation of Solar Cell Modules," *Turkish Journal of Electromechanics & Energy*, vol.1, no, pp. 5-12, March 2016.
- [14] N. Badi, T. A. Manfo, S. A. Alghamdi, A. S. Alatawi, A. Almasoudi, A. Lakhout, A. S. Roy, A. Ignatiev, "Thermal effect on curved photovoltaic panels: Model validation and application in the Tabuk region," *PLoS ONE*, vol. 17, no. 11, pp. 1-16, November 2022. Doi: 10.1371/journal.pone.0275467
- [15] T. A. Manfo, "Promising Cathode Materials for Rechargeable Lithium-Ion Batteries: A Review," *Journal of Sustainable Energy*, vol. 14, no:1 pp. 51-58, June 2023. Doi: 10.0909/JSE.2023660090
- [16] V. Etacheri, R. Marom, R. Elazari, G. Salitra, D. Aurbach, "Challenges in the development of advanced Li-ion batteries: a review," *Energy & Environmental Science*, vol. 4, no. 9, pp. 3243-3262, January 2011. Doi: 10.1039/C1EE01598B
- [17] T. A. Manfo, "A Comprehensive Analysis of Material Revolution to Evolution in Lithium-ion Battery Technology," *Turkish Journal of Materials*, vol. 8, no:1, pp.1-3, July 2023.
- [18] N. Badi, T. A. Manfo, S. A. Alghamdi, H. A. Al-Aoh, A. Lakhout, P.K. Singh, M. N. F. Norrrahim, G. Nath, "The Impact of Polymer Electrolyte Properties on Lithium-Ion Batteries," *Polymers*, vol.14, pp. 3101, July 2022. Doi: 10.3390/polym14153101
- [19] P. Debaeke and A. Aboudrare, "Adaptation of crop management to water-limited environments," *European Journal of Agronomy*, vol. 21, no.4, pp. 433-446, December 2004. Doi: 10.1016/j.eja.2004.07.006
- [20] D. D. Fangmeier, D. J. Garrot, C. F. Mancino, and S. H. Husman, S. H. "Automated Irrigation Systems Using Plant and Soil Sensors," *ASAE Publication, No:4-90*, pp. 533-537, Michigan, USA, 1990.
- [21] J. E. Ayars, C. J. Phene, R. B. Hutmacher, K. R. Davis, R. A. Schoneman, S. S. Vail, and R. M. Mead, "Subsurface drip irrigation of row crops: a review of 15 years research at the Water Management Research Laboratory," *Agricultural Water Management*, vol. 42, pp. 1-27, 1999.
- [22] A. G. Bayrakçı, G. Koçar, "Utilization of renewable energies in Turkey's agriculture," *Renewable and Sustainable Energy Reviews*, vol. 16, pp.618-633, January 2012. Doi: 10.1016/j.rser.2011.08.027.
- [23] M. Arık, İ. Korkut, "Irrigation in Agriculture and Automation Based Irrigation Systems (Mini-Review)," *Gazi University Journal of Science Part C: Design and Technology*, vol. 10, no. 2, pp.360-367, 2022. Doi: 10.29109/gujsc.1108504.
- [24] B. Çakmak, T. Aküzüm, B. Benli, "Water problem in the world in the 21st century," *7th Culture Technique Congress*, Nevşehir, Türkiye, 1999, pp. 8-16.
- [25] G. Dearib, "Cooperative Automatic Irrigation System using Arduino," *International Journal of Science and Research*, vol. 6, no. 3 pp. 1781-1787, March 2017. Doi: 10.21275/ART20171731
- [26] S. Rakshak, R. W. Deshpande, "Automated Irrigation System Based on Arduino Controller Using Sensors," *International Journal of Innovative Research in Computer and Communication Engineering* vol. 5, no. 7, pp. 13394-13400, 2017.
- [27] H. T Ingale, N. Kasat, "Automated Irrigation System," *Proceedings of the International Journal of Engineering Research and Development*, vol. 4, November 2012.
- [28] C. Yılmaz, E. Sefer, M. E. Şahin, "Greenhouse Automation with Solar Cell," *Proceedings of EEMGG2021*, Trabzon Türkiye,

September 2021, pp.91-97.

- [29] K. Taneja, S. Bhatia, "Automatic Irrigation System using Arduino UNO," *International Conference on Intelligent Computing and Control Systems ICICCS*, Madurai-India, June 2017. Doi: 10.1109/ICCONS.2017.8250693
- [30] V. Ramanjaneyulu, K. Devendra Reddy, P. Madhuri, "DTMF Based Irrigation Water Pump Control System," *International Journal of Research*, vol. 5, no.12, pp. 579-582, April 2018.
- [31] R. Senol, "Agricultural Irrigation, and Solar Energy," *Gazi University Engineering Journal of the Faculty of Architecture*, vol. 27, no.3, pp. 519-526, 2020.
- [32] M. Baytürk, G. Çetin A. Çetin, "The Application of Internet Based Greenhouse Automation System Designed with Embedded Server," *Journal of Information Technologies*, vol.6, no.2, pp.653-657, 2013.
- [33] İ. Şahin, M. H. Calp, A. Özkan, "An Expert System Design and Application for Hydroponics Greenhouse Systems," *Gazi University Journal of Science*, vol. 27, no. 2, pp. 809-822, January 2014.
- [34] A. Kurklu, and N. Caglayan, "A Study on the Development of Greenhouse Automation Systems," *Akdeniz University Journal of the Faculty Agriculture*, vol.18, no.1, pp. 25-34, 2005
- [35] A. Sener, "Freeze-Cold Warning and Automatic Heating in Greenhouses, Extreme Hot Warning and Automatic Ventilation Cooling System." Master's Thesis, Yüzüncü Yıl University Institute of Science, Van, Türkiye, 1990.
- [36] N. Durmaz, "A Study on gradual and automatic opening and closing of ventilation covers in greenhouses." Master's Thesis, Akdeniz University, Institute of Science, Antalya, Türkiye, 1994.
- [37] S. R. Barkunan, V. Bhanumathi, J. Sethuram, "Smart sensor for automatic drip irrigation system for paddy cultivation," *Computers, and Electrical Engineering*, vol. 73, pp. 180-193, January 2019. Doi:10.1016/j.compeleceng.2018.11.013
- [38] C. Küçüksayan, "The Importance of Automatic Irrigation in Landscape Applications and Examination of Its Application in the City of Ankara." Master Thesis, Bartın University Institute of Science and Technology, Bartın, Türkiye, 2010.
- [39] K. Obaideen, B. A. A. Yousef, M. N. AlMallahi, Y. C. Tan, M. Mahmoud, H. Jaber, M. Ramadan, "An overview of smart irrigation systems using IoT," *Energy Nexus*, vol. 7, pp. 100124, 2022. Doi: 10.1016/j.nexus.2022.100124
- [40] D. Yavuz, R. Topak, N. Yavuz, "Determining energy consumption of sprinkler irrigation for different crops in Konya Plain," *Turkish Journal of Agricultural and Natural Sciences*, vol. 1, no.3, pp.312-321, 2014.
- [41] S. Khan, M. A. Khan, M. A. Hanjra, J. Mu, "Pathways to reduce the environmental footprints of water and energy inputs in food production," *Food Policy*, vol. 34, no.2, pp.141-149, 2009. Doi: 10.1016/j.foodpol.2008.11.002
- [42] H. G. Mobtaker, A. Keyhani, A. Mohammadi, S. Rafiee, A. Akram, "Sensitivity analysis of energy inputs for barley production in Hamedan Province of Iran," *Agriculture, Ecosystems & Environment*, vol. 137, no.3, pp.367-372, 2010. Doi:10.1016/j.agee.2010.03.011
- [43] C. Sivaji, M. Ramachandran, V. Prasanth, S. Sriram, S. Sowmiya, "Application of Arduino Devices in various IOT Application," *Renewable and Nonrenewable Energy*, vol 1, no.1, June 2022. Doi: 10.46632/rne/1/1/7
- [44] A. Hassan, S. B. Sheng, W. M. Shah, and N. Bahaman, An Automated Irrigation System Using Arduino Microcontroller. *Chapter 1 In book: Internet of Things: Usage and Application, Publisher: Penerbit Universiti Teknikal Malaysia*, Melaka. pp.1-13, 2018.

This is an open access article under the CC-BY license

