



Research Paper / Makale

Experimental Analysis of Exergy Loss for Different Plate Surface Angles in Plate Heat Exchangers

Bayram KILIÇ^{1a*}, Osman İPEK^{2b}

¹Burdur Mehmet Akif Ersoy University, Technical Sciences Vocational School, Burdur, Türkiye

²Süleyman Demirel University, Engineering Faculty, 32260, Isparta, Türkiye

*bayramkiliç@mehmetakif.edu.tr

Received/Geliş: 03.02.2022

Accepted/Kabul: 04.04.2022

Abstract: In this study, experimentally investigated exergy loss for different plate surface angles in the plate heat exchangers. Chevron angles of plate heat exchangers are 30° and 60°. Firstly, an experimental setup used a plate heat exchanger was constructed. Performance analyses for different plate surface angles in plate heat exchangers were investigated. The heat transfer rate and exergy loss are determined. Results of the study show that heat transfer rate and exergy loss for 60° is higher than 30°. The maximum heat transfer rate for 60° is about 35 kW. The minimum heat transfer rate for 60° is about 23 kW. The maximum exergy loss value for 60° is about 33 kW. The minimum exergy loss value for 60° is about 13 kW. The results of the study are given graphically.

Keywords: Exergy loss, heat transfer, plate heat exchangers, chevron angles, effectiveness

Plakalı Isı Eşanjörlerinde Farklı Plaka Yüzey Açılımları için Ekserji Kaybının Deneysel Analizi

Öz: Bu çalışmada, plakalı ısı eşanjörlerinde farklı plaka yüzey açıları için ekserji kaybı analizi deneysel olarak incelenmiştir. Plakalı ısı eşanjörlerinin plaka yüzey açıları 30° ve 60°'dir. Çalışma için ilk olarak, plakalı ısı eşanjörü kullanılan deney düzeneği oluşturulmuştur. Plakalı ısı eşanjörlerinde farklı plaka yüzey açıları için performans analizleri yapılmıştır. Isı transfer miktarı ve ekserji kaybı belirlenmiştir. Çalışmanın sonuçları, 60° plaka yüzey açısına sahip plakalı ısı eşanjöründeki ısı transfer miktarının ve ekserji kaybının 30° plaka yüzey açısına sahip plakalı ısı eşanjöründen daha yüksek olduğunu göstermektedir. 60° plaka yüzey açısına sahip plakalı ısı eşanjörü için maksimum ısı transfer miktarı yaklaşık 35 kW'dır. 60° plaka yüzey açısına sahip plakalı ısı eşanjörü için minimum ısı transfer oranı yaklaşık 23 kW'dır. 60° plaka yüzey açısına sahip plakalı ısı eşanjörü için maksimum ekserji kaybı değeri yaklaşık 33 kW'dır. 60° plaka yüzey açısına sahip plakalı ısı eşanjöründeki için minimum ekserji kaybı değeri yaklaşık 13 kW'dır. Çalışmadan elde edilen sonuçlar grafiksel olarak verilmiştir.

Anahtar Kelimeler: Ekserji kaybı, ısı transferi, plakalı ısı eşanjörleri, plaka yüzey açısı, etkinlik

1. Introduction

Heat transfer between more than one fluid at different temperatures and separated from each other with solid walls is very important in many engineering applications. A device that performs this kind of heat transfer is referred to as a heat exchanger. Plate heat exchangers (PHEs) are widely used in volume heating, air-conditioning plants, thermal power plants, chemical processes, and recovery of waste heat. Heat transfer surfaces are usually thin metal plates in PHEs. These metal surfaces can be flat or wavy form. PHEs usually have a higher total heat transfer coefficient than shell-tube heat exchangers. The decreasing of the transferred heat amount from the heat exchangers

How to cite this article

Kılıç B., İpek O., "Experimental Analysis of Exergy Loss for Different Plate Surface Angles in Plate Heat Exchangers", El-Cezeri Journal of Science and Engineering, 2022, 9 (3); 1061-1068.

Bu makaleye atıf yapmak için

Kılıç B., İpek O., "Plakalı Isı Eşanjörlerinde Farklı Plaka Yüzey Açılımları için Ekserji Kaybının Deneysel Analizi", El-Cezeri Fen ve Mühendislik Dergisi, 2022, 9(3); 1061-1068.

ORCID: ^a0000-0002-8577-1845, ^b0000-0002-7069-1615

causes decreasing in heat exchanger performance. This means a capacity decrease in the system. Improvement of the heat transfer means optimum system dimension and fewer system costs and fewer operating costs.

Gupta and Das realized the exergy loss of heat exchangers in a turbulent flow. Exergy loss has been estimated for used configuration in their study. They presented the accurate perspective of exergy loss and the result optimization of heat exchangers from the exergy viewpoint [1]. San and Pai investigated the exergy loss of heat exchangers for waste heat recovery. The result of their study shows that the exergy efficiency increases with the number of thermal unit (NTU) [2]. San investigated exergy analysis of heat exchangers for waste heat recovery. San determined that estimation of recovered thermal exergy affects the design of the heat exchanger [3]. Pandey and Nema examined the effects of alumina and water as coolants on heat transfer and exergy loss in a PHE. They carried out the heat transfer properties improve with an increase in Re and Peclet number and with a decrease in nanofluid concentration. Pandey and Nema determined the constant of exergy loss for water. They determined among coolants used in the experiment, exergy loss was lowest with 2 vol. % nanofluid for a coolant flow [4]. Pandey and Nema carried out exergy loss reduction in PHE. They used a corrugation angle of 30° in PHE and Reynolds numbers were in the range of 650-2600 and 400-1650 for water and air, respectively. Pandey and Nema determined that the exergy loss in the sinusoidal PHE is less than in the rectangular wavy PHE [5]. Wang et al. worked on the design of PHEs in detail. They designed the optimum plate heat exchanger by designing a mathematical model. The designed model helped to reduce the cost of energy consumption [6]. Jafari et al. have performed a performance analysis of a brazed PHE. Their results showed that brazed joints are an important design parameter in brazed PHEs [7]. Panday and Singh investigated the effects of wire splices in the channel flow path on thermal and hydraulic performance in PHEs. From their experimental results, both Nusselt number and efficiency correlations were derived for use in PHEs [8]. Panday and Singh experimentally investigated the effects of flow type and thermal variables in PHEs. The results showed that the flow distribution becomes more uneven as the number of plates increases [9].

In the literature, experimental studies on the second-law analysis of different plate surface angles (PSAs) of PHEs are very limited. In this study, the influence of PSAs of PHEs on irreversibility is experimentally investigated.

2. Experimental Procedure and Heat Transfer Analysis

The experimental setup consists of PHEs, boiler, hot water tank, valves, heaters, pumps, flow meter, expand box, thermocouples. Temperature and flow rates can be set in the experimental setup. Pumps can work as with three stages. Flow rates can be set with these pumps. When the experimental setup is operated, hot water in the boiler transmit to the PHEs by a pump. Coldwater from the water tank is transmitted to the PHE by a pump. Thereafter, heat transfer occurs between two fluids in PHE. Heated water out from the system while cooled water returns to the boiler. The experimental setup is shown in Figure 1. Chevron angles used in experiments are $\beta=30^\circ$ and $\beta=60^\circ$ (Figure 2).

The heat transfer rate in the PHE is expressed as [11] (Eq. 1-3):

$$\dot{Q} = \dot{m}_h c_{ph}(T_{hi} - T_{ho}) = \dot{m}_c c_{pc} (T_{ci} - T_{co}) \quad (1)$$

$$\dot{Q} = UA\Delta T_{LMTD} \quad (2)$$

$$\Delta T_{LMTD} = \frac{(T_{hi} - T_{co}) - (T_{ho} - T_{ci})}{\ln \frac{(T_{hi} - T_{co})}{(T_{ho} - T_{ci})}} \quad (3)$$

Maximum heat capacity for fluids in PHE is [11-12] (Eq. 4-5):

$$C_h = \dot{m}_h c_{ph} \quad (4)$$

$$C_c = \dot{m}_c c_{pc} \quad (5)$$

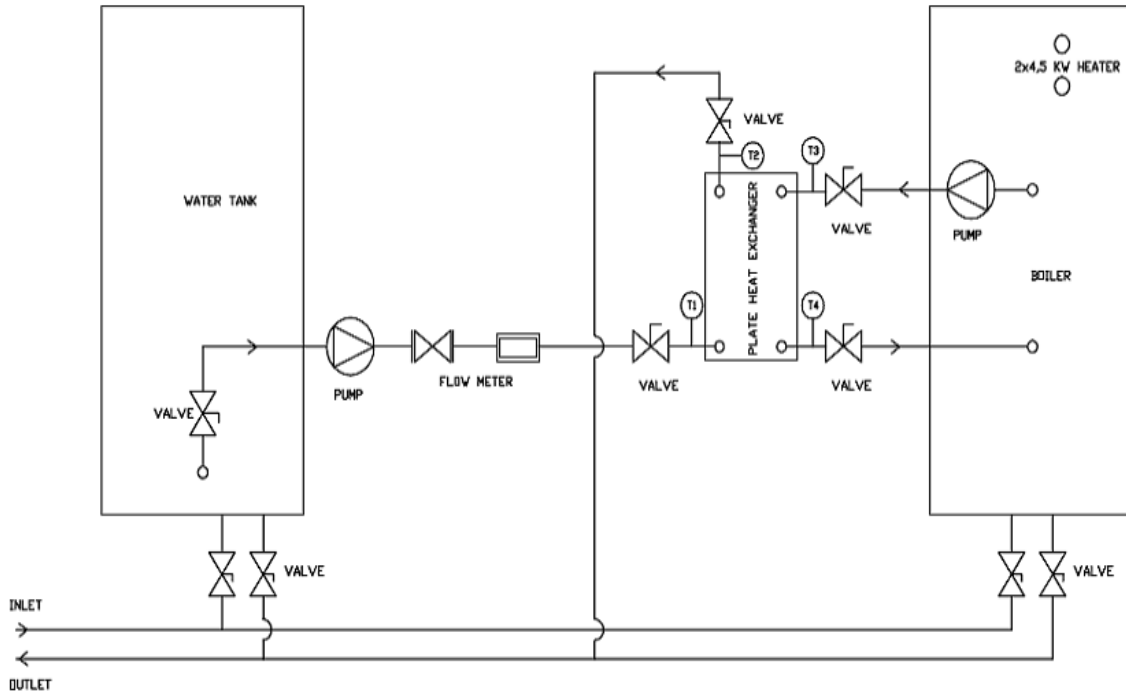

Figure 1. Experimental setup [10]

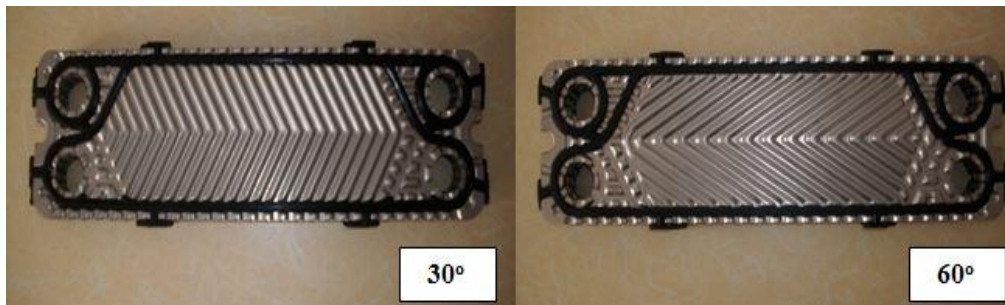

Figure 2. Plates have different plate surface angles [10]

Exergy loss for experimental setup can be determined as follows [13-14] (Eq. 6-10):

$$\dot{Q} = E_h + E_c \quad (6)$$

The exergy changes for the two fluids are calculated as [15-18]:

$$E_h = T_e [\dot{m}_h (s_{ho} - s_{hi})] \quad (7)$$

or

$$E_h = T_e [C_h \ln(T_{ho}/T_{hi})] \quad (8)$$

$$E_c = T_e [\dot{m}_c (s_{co} - s_{ci})] \quad (9)$$

or

$$E_c = T_e [C_c \ln(T_{co}/T_{ci}) - \dot{m}_c R_c \ln(P_e - P_i)] \tag{10}$$

where, A: heat transfer area of the plate, (m²), c_p: specific heat capacity, (kJ/kgK), C : heat capacity (W/K), E : Exergy loss, [W], \dot{m} : mass flow rate (kg/s), Nu: nusselt number, \dot{Q} : heat transfer rate, (W), P : pressure, (Pa), PSAs: plate surface angles, PHEs: plate heat exchangers, s: specific entropy (kJ/kgK), T: temperature, (K), U: total heat transfer coefficient, (W/m²K), ΔP : pressure loss between inlet and outlet of a channel, (Pa), ΔT_{LMTD} : logarithmic mean temperature difference, (°K). The subscripts are given as c: cold fluid, h: hot fluid, i: inlet, o: outlet, e: environmental.

3. Results and Discussion

In this study, exergy loss for different PSAs in the PHEs was investigated experimentally. Effects on exergy loss of plate surface angles were determined. In addition, the variation of exergy loss with different flow rates for different plate surface angles was investigated. Figures 3 and 4 show the variation of the heat transfer rate and effectiveness with chevron angles for 30° and 60°. The results of the study show that the heat transfer rate and effectiveness for 60° are higher than that of the other. As it can be appreciated from Figure 3, the peak heat transfer rate for 30° is about 23 kW. The minimum heat transfer rate for 30° is about 16 kW. As it can be appreciated from Figure 3, the maximum effectiveness for 30° is about 0.45. The minimum effectiveness for 30° is about 0.43. As it can be appreciated from Figure 4, the peak heat transfer rate for 60° is about 35 kW. The minimum heat transfer rate for 60° is about 23 kW. As it can be appreciated from Figure 4, the maximum effectiveness for 60° is about 0.50. The minimum effectiveness for 60° is about 0.43. It is seen that the heat transfer rate increases as the temperature difference between the hot and cold water inlet temperatures in the PHE increases. Similarly, it is seen that increase in the effectiveness of the PHE.

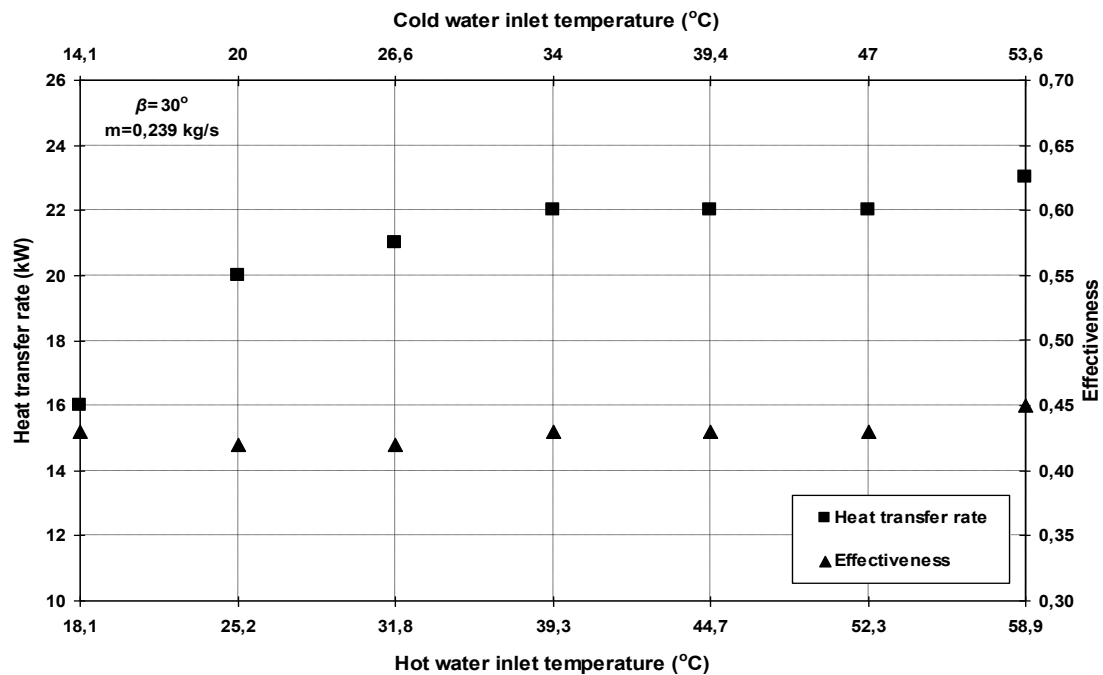

Figure 3. Variation of heat transfer rate and effectiveness with inlet temperatures of fluids for $\beta=30^\circ$

According to the results of the study, the most important variables affecting the heat transfer for the PHEs are PSA and fluid rate. Heat transfer can be successfully improved by optimizing the plate surface angle. Thus, effectiveness can be improved effectively by controlling the variables relating

to the plate surface angle and fluid rate. When we look at the results of the efficiency analysis, it is seen that it is similar to the results in Ref. [11].

Figure 5 shows the relationship between Nu and Re for different plate surface angles. In Figure 5, the results of the experimental study were compared with empirical correlations defined by Gut, Maslow, and Kovalenko. As it can be appreciated from Figure 5 these researchers obtained correlations good match within the obtained from experiments. Figure 5 shows us that the angle of the plate surface creates a secondary flow and provides an additional effect of turbulence to fluid. Thus, the Nusselt number increases with the Reynolds number. This situation increases the heat transfer coefficient and heat transfer rate. The results of this study show that the maximum heat transfer rate has been obtained for $\beta=60^\circ$. The minimum heat transfer rate has been obtained for $\beta=30^\circ$.

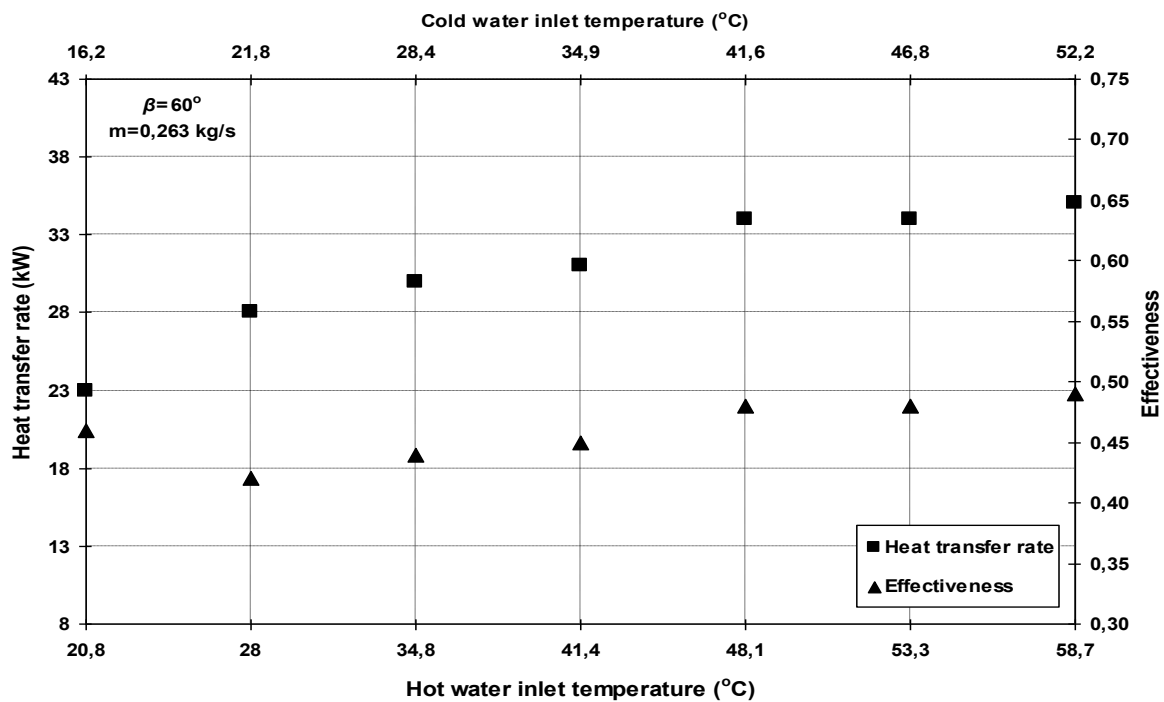

Figure 4. Variation of heat transfer rate and effectiveness with inlet temperatures of fluids for $\beta=60^\circ$

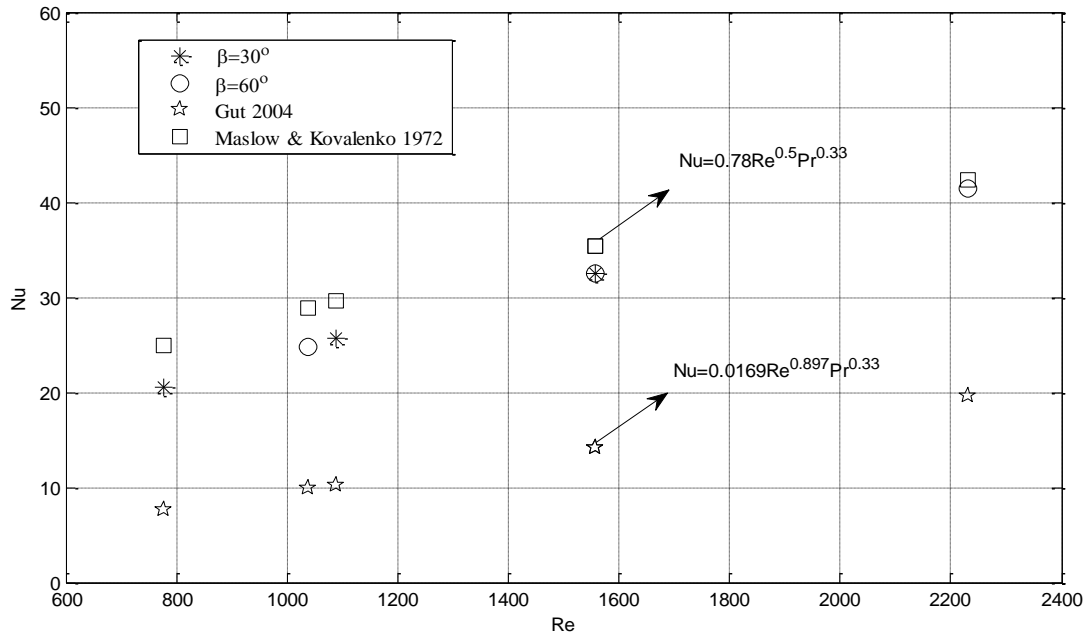

Figure 5. Variation of Nu with Re for different plate surface angles

Figure 6 shows the relationship between exergy loss and mass flow rate. The results of the study show that exergy loss for $\beta=60^\circ$ is higher than $\beta=30^\circ$. As it can be appreciated from Figure 6, the maximum exergy loss for $\beta=60^\circ$ is about 33 kW. The minimum exergy loss for $\beta=60^\circ$ is about 13 kW. The maximum exergy loss for $\beta=30^\circ$ is about 18 kW. The minimum exergy loss for $\beta=30^\circ$ is about 13 kW. In experiments is seen that both the heat transfer rate and the exergy loss value are very high for $\beta=60^\circ$. The reason for this, the high-temperature differences are used in the calculations. Heat transfer rates and exergy loss values have increased depending on the high-temperature difference. As can be seen from the analysis, exergy loss varies with heat transfer rate and flow rate in the PHEs.

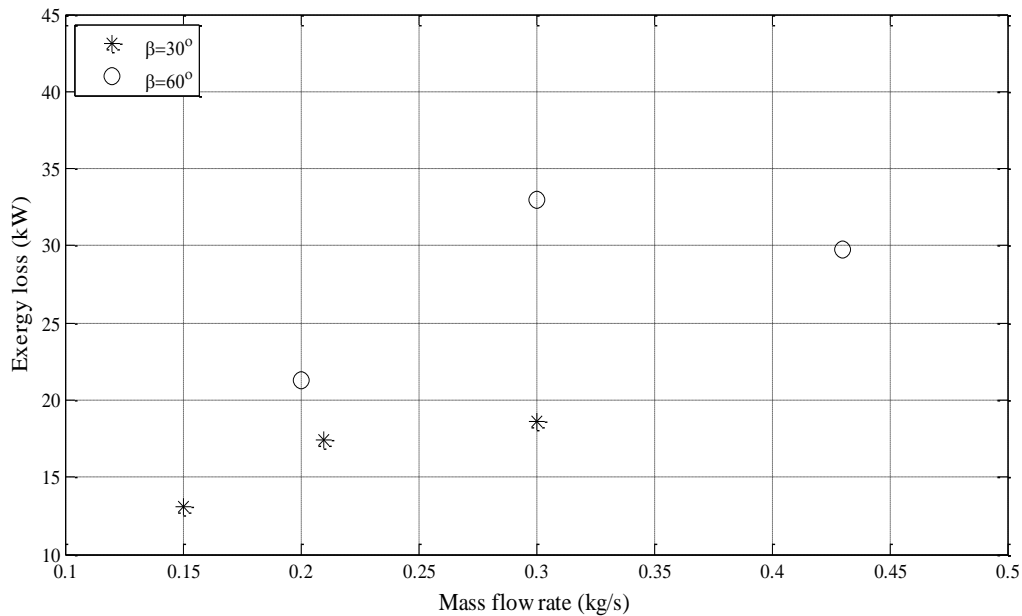

Figure 6. Variation of exergy loss with mass flow rate

4. Conclusions

In this study, exergy loss for different PSAs in the PHEs was investigated experimentally. It was determined that the exergy loss and the heat transfer rate gained from corrugated chevron PHE with 60° is higher than 30° . The maximum heat transfer rate for 60° is about 35 kW. The minimum heat transfer rate for 60° is about 23 kW. The maximum exergy loss for 60° is about 33 kW. The minimum exergy loss for 60° is about 13 kW. The determination of the optimum operating conditions and plate surface angle is the most appropriate solution for reducing exergy losses in PHEs. Moreover, we were foreseen that exergy loss will reduce when PHE is isolated. Because heat transfer will be blocked between the PHE and the environment. The optimal design of PHEs is very important in the efficient use of energy. We believe that the results of this study will benefit the companies that produce PHEs.

Acknowledgment

This work was supported by the Süleyman Demirel University Research Foundation (SDUBAP) financial support, under Project Number: 2810-D-11.

Authors' Contributions

BK and OI designed the structure. BK carried out the experiments work, the theoretical calculations, in collaboration with OI, and wrote up the article. OI is the overall supervisor of the project. Both authors read and approved the final manuscript.

Competing Interests

The authors declare that they have no competing interests.

References

- [1]. Gupta, A., Das, K., Second law analysis of crossflow heat exchanger in the presence of axial dispersion in one fluid, *Energy*, 2007, 32, 664-672.
- [2]. San, J., Pai, K., Performance of a serpentine heat exchanger: Part II-Second-law efficiency, *Applied Thermal Engineering*, 2009, 29, 3088-3093.
- [3]. San, J., Second-law performance of heat exchangers for waste heat recovery, *Energy*, 2010, 35, 1936-1945.
- [4]. Pandey, S., Nema, V.K., Experimental analysis of heat transfer and friction factor of nanofluid as a coolant in a corrugated plate heat exchanger, *Experimental Thermal and Fluid Science*, 2012, 38, 248-256.
- [5]. Pandey, S., Nema, V.K., An experimental investigation of exergy loss reduction in corrugated plate heat exchanger, *Energy*, 2011, 36, 2997-3001.
- [6]. Wang, B., Arsenyeva, O., Zeng, M., Klemes, J.J., Varbanov, P.S., An advanced Grid Diagram for heat exchanger network retrofit with detailed plate heat exchanger design, *Energy*, 2022, 248, 123485.
- [7]. Jafari, A., Sadeghianjahromi, A., Wang, C., Experimental and numerical investigation of brazed plate heat exchangers-A new approach, *Applied Thermal Engineering*, 2022, 200, 117694.
- [8]. Panday, N.K., Singh, S.N., Study of thermo-hydraulic performance of chevron type plate heat exchanger with wire inserts in the channel, *International Journal of Thermal Sciences*, 2022, 173, 107360.

- [9]. Panday, N.K., Singh, S.N., Experimental study of flow and thermal behavior in single and multi-pass chevron-type plate heat exchangers, *Chemical Engineering & Processing: Process Intensification*, 2022, 171, 108758.
- [10]. Kılıç. B., Experimental investigation of effects to heat transfer of plate geometry with dynamic and thermal parameters in the plate heat exchangers. Ph.D. Thesis, Süleyman Demirel University, The Graduate School of Natural and Applied Sciences, Isparta, 2013.
- [11]. Genceli, O., *Isı Değiştiricileri*. Birsen Yayınevi, Türkiye, 1999.
- [12]. Gherasim, I., Taws, M., Galanis, N., Nguyen, T., Heat transfer and fluid flow in a plate heat exchanger part I. Experimental investigation, *International Journal of Thermal Sciences*, 2011, 50, 1492-1498.
- [13]. Han, H., Cui, Q., Chen, J., Chen, M., Wang, Q., A numerical and experimental study of chevron, corrugated-plate heat exchangers, *International Communication in Heat and Mass Transfer*, 2010, 37, 1008-1014.
- [14]. Hayes, N., Jokar, A., Ayub, H., Study of carbon dioxide condensation in chevron plate exchangers; heat transfer analysis, *International Journal of Heat and Mass Transfer*, 2011, 54, 1121-1131.
- [15]. Kotcioglu, I., Cansız, A., The efficiency analysis of a finned cross-flow heat recovery unit, *Experimental Heat Transfer*, 2015, 28, 9-22.
- [16]. Bilen, K., Demir, O., Hava, Su ve Toprak Kaynaklı Isı Pompalarının Farklı Soğutucu Akışkanlar için Enerji ve Ekserji Analizi, *El-Cezerî Fen ve Mühendislik Dergisi*, 2021, 8 (2), 688-705.
- [17]. Baysal, E., Solmaz, Ö., Ökten, M., Başeski, Y., İç İç Borulu Isı Değiştiricide Zıt Akışta Türbülötör Kullanımının Basınç Değişimine Etkisinin Sayısal Olarak İncelenmesi, *El-Cezerî Journal of Science and Engineering*, 2021, 8 (2), 817-826
- [18]. Tom, B, Kayabasi, E., Design and Simulation of a Microchannel Heat Exchanger for Cooling a Micro Processor Using Ethylene, *El-Cezerî Journal of Science and Engineering*, 2021, 8 (3), 1243-1253.