

## Isolated MPPT, CC, CV Solar Battery Charger Design and Application

Görkem ÖZKUR<sup>1</sup> , Hüseyin YEŞİLYURT<sup>1\*</sup> 

<sup>1</sup>Izmir Katip Celebi University, Department of Electrical and Electronics Engineering, Izmir/Turkey

**Received:**18/04/2022, **Revised:** 06/07/2022, **Accepted:** 06/07/2022, **Published:** 31/03/2023

### Abstract

With the rapid increase in energy consumption, the production and storage of solar energy from renewable energy sources has become an important subject. The problem of low-efficiency energy transfer from the solar panel has been overcome with the maximum power point tracking (MPPT) methods and algorithms. In this study, an isolated MPPT, constant current (CC), constant voltage (CV) solar battery charging circuit with perturb and observe (P&O) algorithm is proposed. Three different modes (MPPT, CC, CV) work together in the proposed solar battery charging circuit. Panel and battery current and voltage values are constantly measured by the microcontroller, and according to these values, the algorithm determines which mode the circuit will operate in. The converter is constantly trying to transfer maximum power to the battery in every mode it operates. The CC and CV modes in the converter also try to achieve maximum power continuously and quickly, and their algorithms are much easier and simpler than traditional PID controls. Another advantage of the algorithm is that it has a direct transition between modes, thanks to its fast response in terms of efficiency and protection. After changing the duty (D) in any mode, it is checked whether it is necessary to switch to the other two modes without returning to the beginning. Theoretical analyses have been verified by the application of a battery charging circuit with 120 W output power, 12 V output voltage and 10 A output current.

**Keywords:** Maximum Power Point Tracking, Solar Energy, Constant Current, Constant Voltage, Battery Charger

## İzoleli MPPT, CC, CV Solar Akü Şarj Devresi Tasarımı ve Uygulaması

### Öz

Enerji tüketiminin hızla artması ile birlikte yenilenebilir enerji kaynaklarından güneş enerjisinin üretimi ve depolanması önemli bir konu haline gelmiştir. Güneş panelinden düşük verimle enerji aktarımı sorunu ise maksimum güç noktası takip (MPPT) yöntemi ve algoritmaları ile birlikte aşılmaya başlanmıştır. Bu çalışmada değişir ve gözle (P&O) algoritmaları, izoleli, MPPT, sabit akım (CC), sabit gerilim (CV) solar akü şarj devresi sunulmuştur. Sunulan solar akü şarj devresinde 3 farklı mod (MPPT, CC, CV) birlikte çalışmaktadır. MPPT yöntemi olarak sade yapılı, değişir ve gözle (P&O) algoritması kullanılmaktadır. Panel ve akü akım – gerilim değerleri sürekli olarak mikroişlemci tarafından ölçülmektedir ve bu değerlere göre algoritma, devrenin hangi modda çalışacağını belirlemektedir. Dönüştürücü çalıştığı her modda sürekli olarak maksimum gücü aküye aktarmaya çalışmaktadır. Dönüştürücüde bulunan CC ve CV modları da sürekli ve hızlı bir şekilde maksimum gücü elde etmeye çalışmaktadır ve algoritmaları geleneksel PID kontrollere göre çok daha kolay ve sadedir. Algoritmanın bir diğer avantajı ise verimlilik ve koruma açısından hızlı tepki vermesi sayesinde modlar arasında direkt geçiş bulundurmasıdır. Herhangi bir modda doluluk oranı (D) değiştirildikten hemen sonra başa dönmeyen diğer iki moda geçilip geçilmemesi gerektiğine bakılmaktadır. Teorik analizler, 120 W çıkış gücü, 12 V çıkış gerilimi ve 10 A çıkış akımı değerlerine sahip akü şarj devresi uygulaması ile doğrulanmıştır.

**Anahtar Kelimeler:** Maksimum Güç Noktası Takibi, Solar Enerji, Sabit Gerilim, Sabit Akım, Akü Şarj Cihazı

## 1. Introduction

With the development of technology, the demand for electrical energy is increasing rapidly, however, many reasons such as the danger of exhaustion of resources like oil and natural gas, non-renewable and harmful to human health encourage people to produce electricity from renewable energy sources [1]. Solar panels are used to generate electricity from the sun, which is an endless source of energy. The biggest problem with electricity generation from solar panels is that low efficiency electricity that can be produced due to variables such as light and temperature [2]. In recent years, maximum power point tracking (MPPT) techniques have been used for higher efficiency electricity generation and storage. MPPT techniques aim to provide the maximum power that can be obtained from the panel according to variable conditions [3].

To implement the MPPT technique, many different methods are used, mainly perturb and observe algorithm (P&O), incremental conductance algorithm (INC), fuzzy logic (FL) [4]. On the other hand, in conventional battery charging systems, constant voltage (CV) and constant current (CC) methods are generally used [5].

DC-DC converters are divided into two groups as isolated and non-isolated. Isolated converters provide isolation by transferring the input power to the output through the transformer. Although isolated converters seem to be disadvantageous due to their higher cost, preference is of great importance in terms of system and human health, and making an isolated design increases the usability and usage areas of the design [6-7].

In this study, P&O algorithm, isolated, MPPT, CC, CV solar battery charging circuit design and application is proposed. In the proposed battery charging circuit, 3 different modes (MPPT, CC, CV) work together. As the MPPT method, the simple structured perturb and observe (P&O) algorithm is used. Thanks to the designed algorithm, the panel and battery current and voltage values are constantly measured, and it determines which mode of the circuit will operate. The circuit is constantly trying to transfer maximum power to the battery in every mode it works. CC and CV modes in the circuit also try to achieve maximum power continuously and quickly, and their algorithms are much easier and simpler than the pre-designed PID controls [8-9-10]. In addition, the proposed battery charging circuit algorithm includes overvoltage protection (OVP), undervoltage protection (UVP), overcurrent protection (OCP) and soft start (SS). The proposed P&O algorithm design has been verified by the application of the battery charging circuit with 120 W output power, 12 V output voltage and 10 A output current.

## 2. Material and Methods

The proposed isolated MPPT, CC, CV solar battery circuit with P&O algorithm converts the energy from the sun into electrical energy with the help of the solar panel. The electrical energy obtained from the solar panel is charged by an isolated DC-DC converter to the battery at the output. While the energy obtained from the solar panel is transferred to the battery, the MPPT algorithm is used, while the MPPT algorithm is provided by the microcontroller. The general scheme of the circuit's operation is shown in Figure 1.

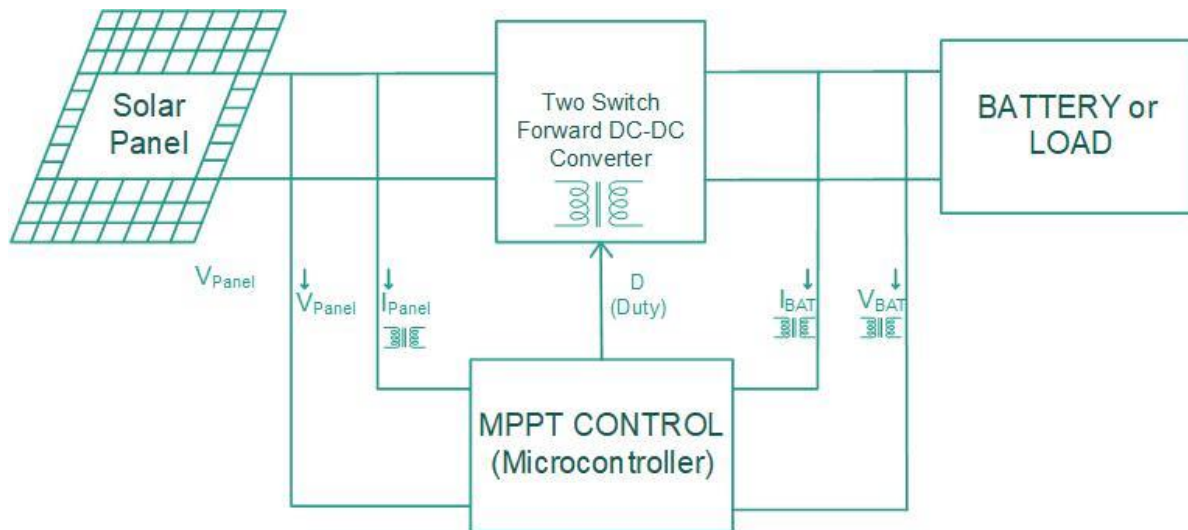

**Figure 1.** General Scheme of Circuit's Opeation.

## 2.1 Solar Panel

Solar panel formed by parallel and series connection of solar cells; it converts the rays coming from the solar energy into electrical energy. There are two types of solar panels, monocrystalline and polycrystalline, and monocrystalline panels have higher efficiency [11].

A monocrystalline solar panel with a power of 150 W is used in the proposed battery charging circuit. The electrical properties of the selected solar panel shared in Table 1.

**Table 1.** Electrical Charecteristics of Proposed Circuit's Solar Panel.

Panel Power	150 W
Max. Open Circuit Voltage	23.8 V
Maximum Point Voltage	20.7 V
Max. Short Circuit Current	7.61 A
Maximum Point Current	7.25 A
Max. System Voltage	1000 V

## 2.2 DC-DC Converter Circuit

The DC electrical energy obtained from the sun is transferred to the battery by isolating it via a two-switch forward DC-DC converter and the battery is charged. In this study, an isolated MPPT, CC, CV solar battery circuit with P&O algorithm by using a two-switch forward converter which is an isolated converter is proposed. The aim of using an isolated converter in the design; to consider system and human health, to make the usage areas of design wider.

Two-switch forward (TSF) DC-DC converters are more advantageous in terms of cost and ease of control than other isolated converters such as half-bridge and full-bridge. TSF converters are known for their durability and they are often used at medium power levels [12].

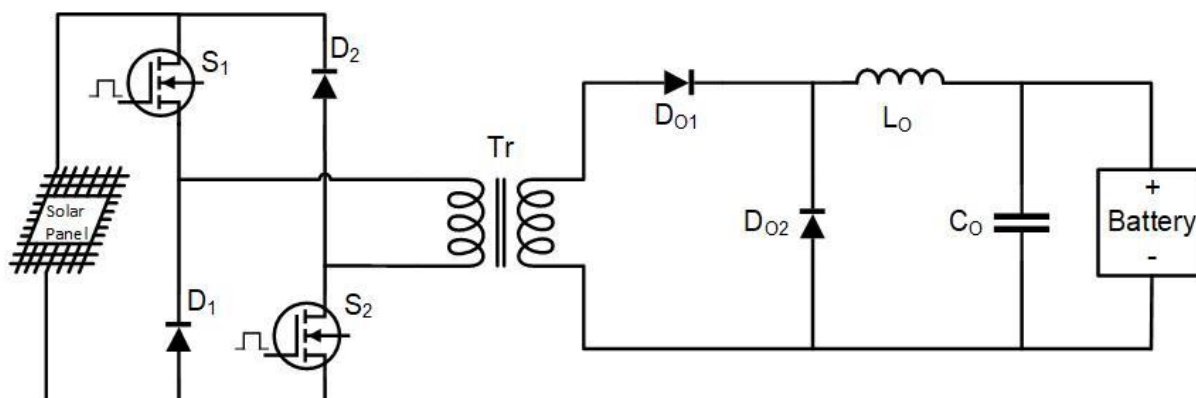

**Figure 2.** Two Switch Forward DC-DC Converter Schematic.

The schematic of the proposed DC-DC converter circuit is shown in Figure 2. DC-DC converter is designed to operate at 16 – 30 V input voltages, considering protection, solar panel electrical properties and cost issues. The converter works up to 120 W power and its control is provided by a microcontroller.

### 2.3 Control – Feedback Circuit

The proposed battery charging circuit is controlled by a microcontroller. In the battery charging circuit, continuous voltage is obtained from the solar panel, but the battery is not charged at low and high panel voltages.

In Figure 3, the electrical characteristic graph of the solar panel is shared. As can be seen from the graph, the panel power takes its maximum value at the point where the panel voltage and current multiply at the maximum.

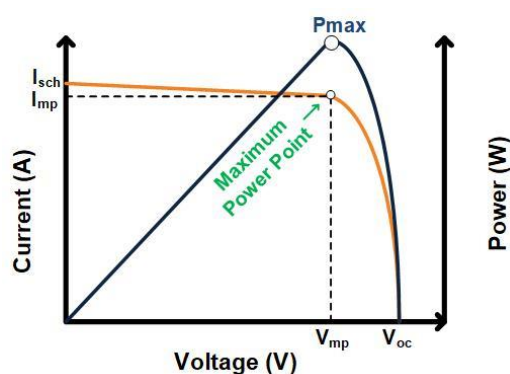

**Figure 3.** Electrical Characteristics of the Solar Panel.

In order to transfer the maximum value of the panel power to the output, the panel current and voltage must be constantly observed. The panel voltage is read in the ADC channel of the microcontroller with the classical voltage divider method. The panel current is read with an isolated hall current sensor considering situations such as short circuit and high current.

Batteries have maximum charge voltage and current values. The proposed solar battery charging circuit has constant current (CC) and constant voltage (CV) modes. In order to use these modes, the battery charging voltage and current must be constantly checked. In the proposed solar battery charging circuit, the battery voltage is transmitted to the microcontroller with isolation by using an optocoupler. The battery charging current is read with isolation by using hall current sensor, just like the panel current.

The solar panel current and voltage and battery charging current and voltage values are continuously read by the microcontroller and the microcontroller generates the PWM signal through the algorithm inside according to the these values and the duty (D) is constantly updated.

## 2.4 Battery

Lead-Acid batteries are the most common types of batteries used from the past to present, due to their low cost and rechargeable nature. Since they give high current, they can be used in projects that require high power and are widely used in solar energy systems, automobiles, etc. [13-14].

The proposed solar battery charging circuit is designed to charge a 12 V – 10 A lead-acid battery. In addition, the circuit is suitable for charging batteries as Li-Ion and LiFePO<sub>4</sub>.

## 3. Control Methodology

The proposed solar battery charging circuit works in 3 different modes with the MPPT method. The microcontroller constantly measures the panel and battery voltage and current values, and takes the average of 50 analog to digital conversion (ADC) readings for each value to reach a clearer result and operates according to the average values. The basic flow diagram of the proposed solar battery charging circuit shown in Figure 4.

According to the flowchart shown in Figure 4, the algorithm has high and low voltage protections, if the solar panel voltage value is outside the determined minimum and maximum values, it does not produce a PWM signal and continues to measure continuously. If the voltage value is within the specified range, which goes to the next step, mode selection.

For the mode selection process, the predetermined  $CV_{limit}$  and  $CC_{limit}$  values are checked.  $CV_{limit}$  value indicates battery charge voltage limit value and  $CC_{limit}$  value indicates battery charge current limit value. If the measured battery voltage is less than the determined  $CV_{limit}$  value and the measured battery current is less than the determined  $CC_{limit}$  value, the MPPT mode works. If the measured battery voltage value is greater than  $CV_{limit}$ , CV mode works. And if the measured battery value is greater than  $CC_{limit}$ , CC mode works.

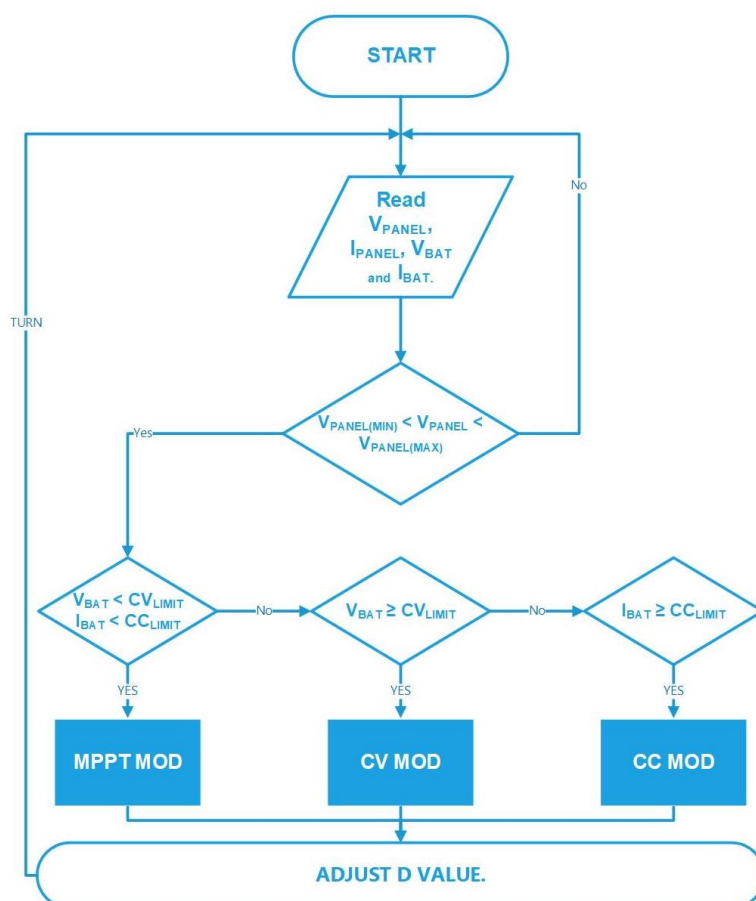

**Figure 4.** Basic Flowchart of the Circuit.

PWM signal is generated according to the D value determined in the operating mode and these signals are transferred to the switches of the two-switch forward DC-DC converter via the isolated drive circuit. And by going back to the beginning, it is checked in which mode the algorithm will work. This process continues continuously until the solar panel is disconnected.

### 3.1 MPPT Mode

If the battery voltage and battery current values are lower than the limit values, it works in MPPT mode. The simple structured P&O algorithm is used as the MPPT method. The basic flowchart of the MPPT mode is shown in figure 5.

The panel power is calculated by multiplying the solar panel voltage  $V_{panel}$  and current  $I_{panel}$  values, which are measured and averaged at the start of the MPPT mode. The calculated power value is compared with the previous power value. If the power has increased, the D value is increased, if the power has decreased, the D value is decreased, and if the power has not changed, the D value remains constant.

Immediately after changing the D value in MPPT mode, it is checked whether the battery voltage and current exceed the CV and CC limit values before the code returns. In such a case, CV or CC mode algorithms are activated directly without returning the code to the beginning.

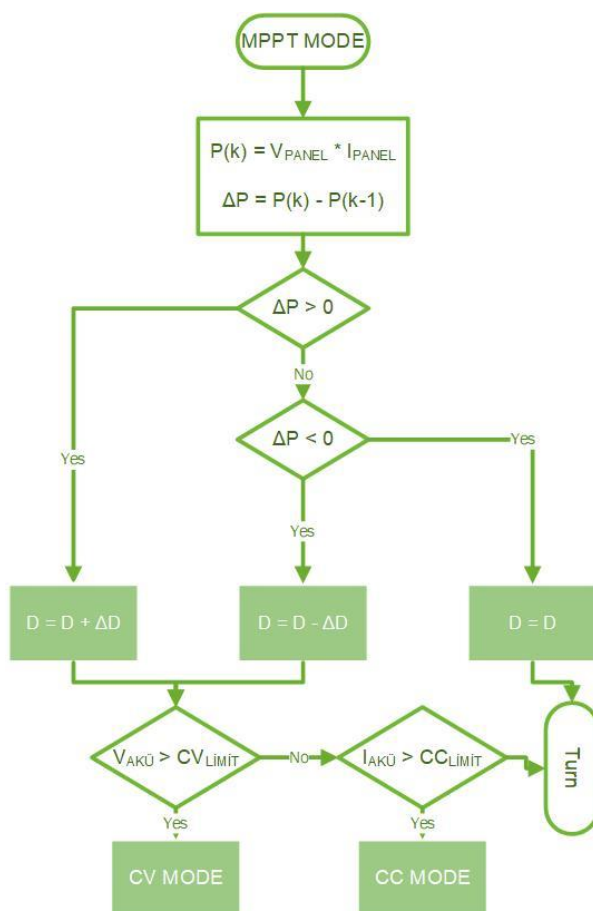

Figure 5. Basic Flowchart of MPPT Mode.

### 3.2 CV Mode

In case the battery voltage is higher than the determined battery charge voltage limit value, the CV mode algorithm starts to work. The basic flow diagram of CV mode operation is shown in figure 6.

When the CV mode starts, the battery voltage is checked again, if it is between the determined minimum and maximum limits, D is increased and the maximum power is tried to be obtained continuously, in line with the MPPT logic. If the battery voltage value is higher than the determined maximum limit, the D value is reduced to prevent damage to the battery and the voltage is reduced to the CV value range.

Just like in MPPT mode, the battery voltage and current values are checked immediately after PWM signal is applied to the switches in CV mode, and if the battery charge current value is greater than  $CC_{limit}$ , the CC mode is started, if the battery charge current value is lower than  $CC_{limit}$  and the battery If the charging voltage value is lower than  $CV_{limit}$ , MPPT mode is started.

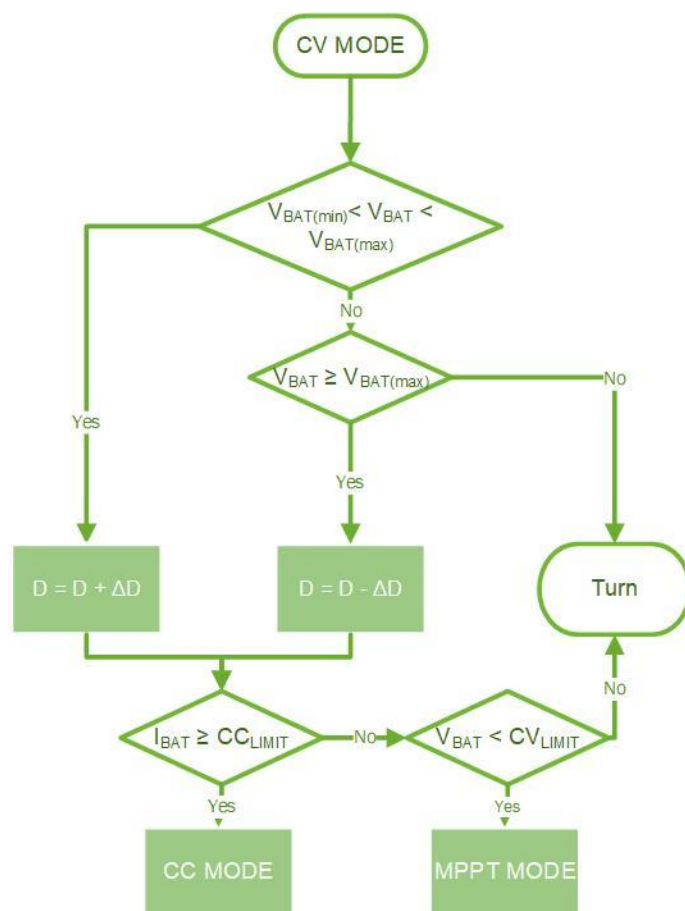

Figure 6. Basic Flowchart of CV Mode.

### 3.3 CC Mode

When the battery charging current is above the specified limit value, the CC mode algorithm starts to work. The basic flow diagram of the CC mode algorithm is shown in Figure 7.

CC mode stages and CV mode stages are similar. When the battery charging current is between the determined limits, the D value is continuously increased to obtain maximum power. If the battery charging current exceeds the maximum limit value, D is reduced.

As in MPPT mode and CV mode, battery charge and voltage values are checked immediately after D value is changed and PWM signal is applied to the switches. If the battery charging voltage is above the  $CV_{limit}$  value, the CV mode, if the battery charging voltage is below the  $CV_{limit}$  value and the charging current is below the  $CC_{limit}$  value, the MPPT mode algorithms start to work.



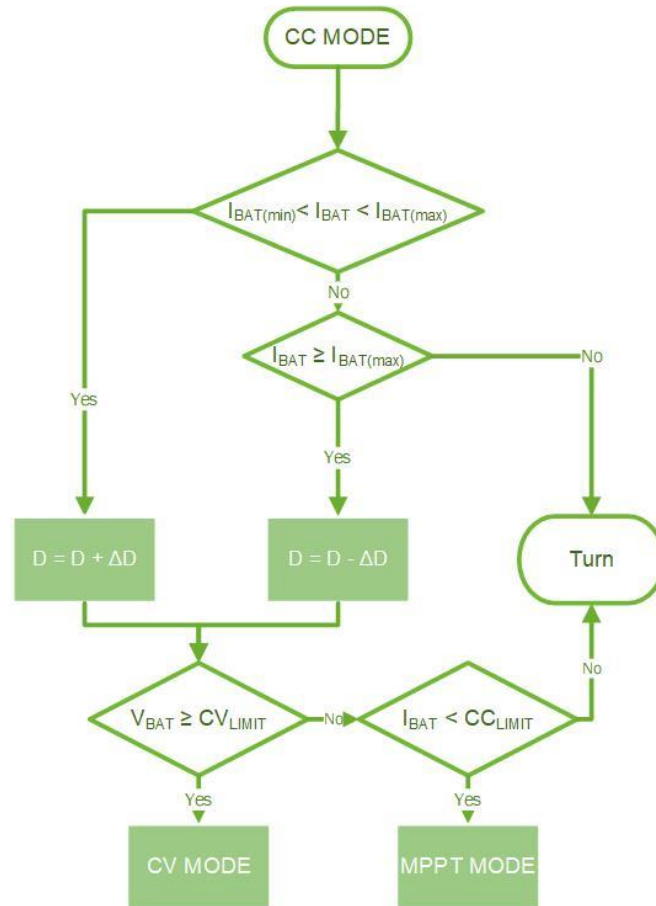

Figure 7. Basic Flowchart of CC Mode.

#### 4. Application and Results

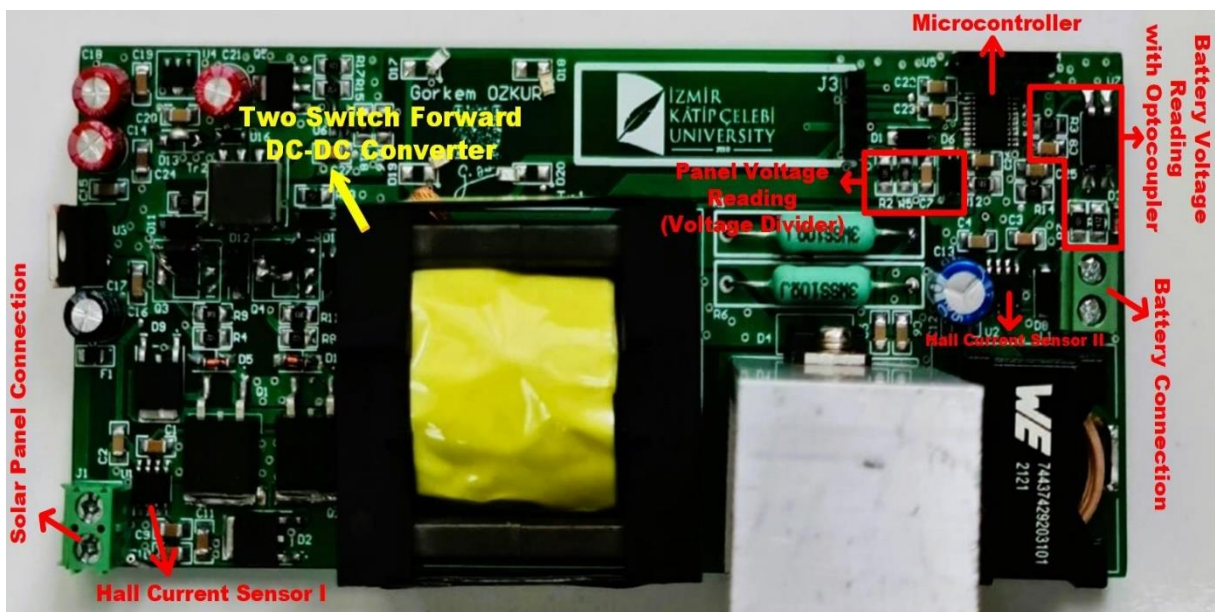
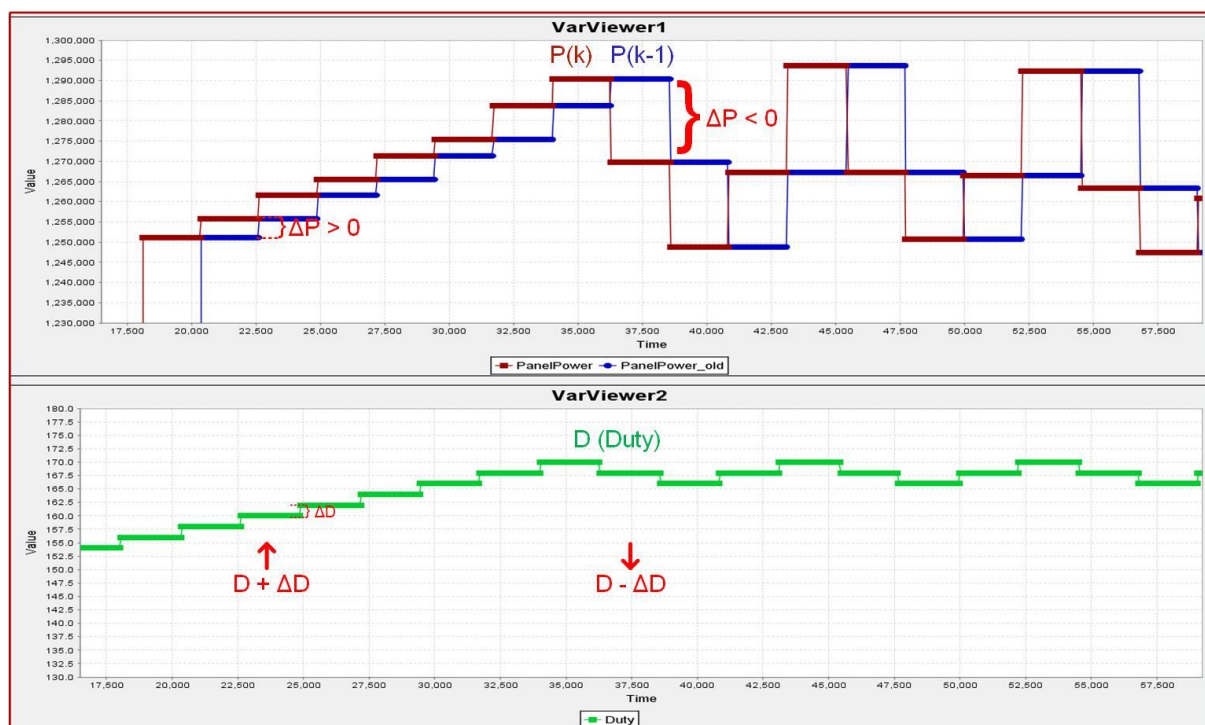

Figure 8. Proposed Solar Battery Charger Circuit.

The PCB design of the presented P&O algorithm, isolated MPPT, CC, CV solar battery circuit is shown in Figure 8. The two-switch forward DC-DC converter of the battery charging circuit presented in Figure 8, the circuits and components of the panel and battery voltage reading methods, solar panel and battery connections, microprocessor location are shown by marking.

The proposed solar charging battery circuit has been connected and tested with the algorithm designed for the circuit. Operating states, output current and voltage signals, PWM signal D change and other signals have been observed in MPPT, CC and CV modes, which are 3 different modes included in the algorithm. The signals were observed as instant value readings together with the program of the application in which the microcontroller was coded.



**Figure 9.** MPPT Mode Operating Graphs of Proposed Design.

In Figure 9, the graph of the circuit working in MPPT mode is shared. At the top of the graph, the panel power old value  $P(k-1)$  and the new measured value  $P(k)$  signals are seen. The lower part of the graph shows the variation of  $D$  in the same range.

Figure 9 shows the change in power with  $\Delta P$  and the change in value with  $\Delta D$ . As explained in the algorithm,  $D$  value increases when  $\Delta P > 0$ ,  $D$  value decreases when  $\Delta P < 0$ , and  $D$  remains constant where power variation is zero.

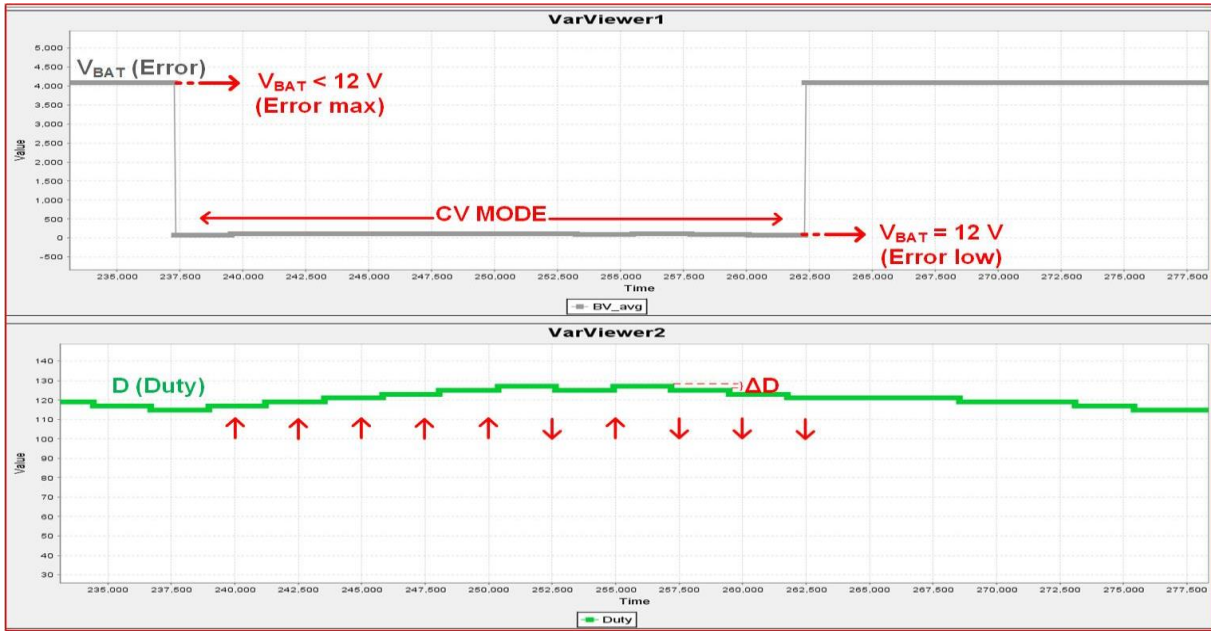

Figure 10. CV Mode Operating Graphs of Proposed Design.

The CV mode operating graph is shown in Figure 10. On the upper part of the graph, there is the battery charge voltage error reading waveform, and on the lower part, there is the D change graph. In the circuit, the battery voltage is read by generating an error signal over the optocoupler. When the battery voltage is less than 12 V, the error is maximum, and when the battery voltage is 12 V, the error takes a determined minimum value.

As can be seen from the graph in Figure 10 in CV mode, while trying to keep the battery voltage constant within a certain range, the D value is constantly increased within this range and maximum power is utilized. As soon as the battery charge voltage exceeds the determined maximum value, D is reduced and put into range again.

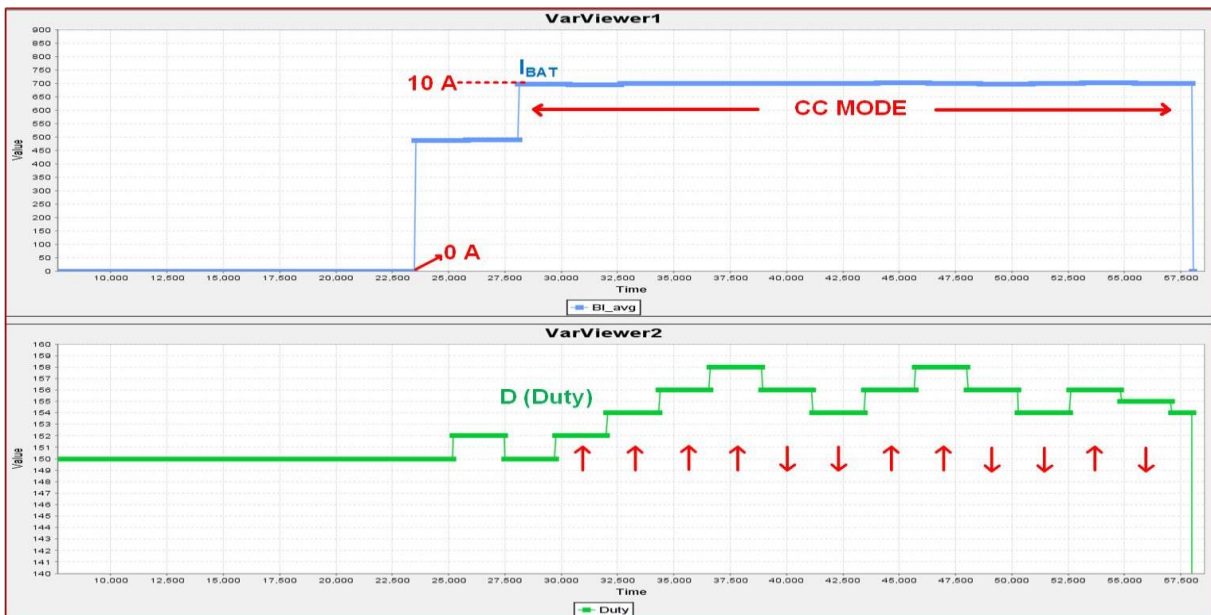

Figure 11. CC Mode Operating Graphs of Proposed Design.

Figure 11 shows the signals of the CC mode application of the solar battery charging circuit. The battery charging current is shown at the top and the D change at the bottom.

CC mod and CV mod work with similar logic. As seen in Figure 11, when the battery charging current is within the determined constant current range, the D value is constantly increasing, and when it exceeds the maximum limit value, it is decreased. Maximum power has been achieved continuously and the protection of the battery has been taken into account. Also, it is seen in the graph that the battery current is 0 for a certain period of time at the beginning, this indicates undervoltage protection, the battery is not charged because the panel voltage is lower than the specified limit value.

## 5. Conclusion

In this study, the design and application of isolated MPPT, CC, CV solar battery charging circuits for solar panels, the use of which is constantly increasing, is proposed. All components of the proposed solar battery charging circuit; solar panel, DC-DC converter, battery and P&O MPPT control algorithm) are explained in detail. The designed algorithm for the proposed solar battery charging circuit and the algorithms of 3 different (MPPT, CC and CV) modes are explained separately. The solar battery charging circuit designed to implement the proposed method and the control connections of the circuit are shared. The proposed method is validated with a solar battery charging circuit with 120 W output power, 12 V – 10 A output voltage and current. In practice, signals belonging to MPPT, CC and CV modes have been examined. Along with the reviews, it has been seen that the algorithms of all three modes are designed to achieve maximum power at all times. It has been seen that the proposed P&O algorithm method, together with the signals and results, can be easily applied for MPPT solar battery charging circuits compared to other algorithms such as its equivalent PID.

## Ethics in Publishing

There are no ethical issues regarding the publication of this study.

## Acknowledgements

Solar Battery Charger with MPPT Algorithm project is supported by TUBITAK within the scope of TUBITAK 2209-A programme.

## References

- [1] Bodur, H., Yesilyurt, H., Ting, N.S., Sahin, Y., (2021), " Zero-voltage switching half-bridge pulse width modulation DC–DC converter with switched capacitor active snubber cell for renewable energy applications", *Int J Circ Theor Appl*, Volume 49, Pages 2686–2698.
- [2] Manokar, A.M., Winston, D.P., Mondol, J.D., Sathyamurthy, R., Kabeel, A.E, Panchal, H., (2018), "Comparative study of an inclined solar panel basin solar still in passive and active mode", *Solar Energy*, Volume 169, Pages 206-216.

- [3] Brito, M. A. G., Galotto, L., Sampaio, L.P., Melo, G.D.A., and Canesin, C.A., (2013), "Evaluation of the Main MPPT Techniques for Photovoltaic Applications," in IEEE Transactions on Industrial Electronics, Volume 60, No 3, Pages 1156-1167.
- [4] Karami, N., Moubayed, N., Outbib, R., (2017) "General review and classification of different MPPT Techniques", Renewable and Sustainable Energy Reviews, Volume 68, Part 1, Pages 1-18.
- [5] Schaefer, F. and Boucsein, W. (2000), "Comparison of electrodermal constant voltage and constant current recording techniques using the phase angle between alternating voltage and current." Psychophysiology, Volume 37, Pages 85-91.
- [6] Tan, N. M. L., Abe T., and Akagi, H., (2012) "Design and Performance of a Bidirectional Isolated DC–DC Converter for a Battery Energy Storage System," in IEEE Transactions on Power Electronics, Volume 27, No 3, Pages 1237-1248.
- [7] Baçoğlu, M.E., Çakır, B., (2016), "Comparisons of MPPT performances of isolated and non-isolated DC–DC converters by using a new approach", Renewable and Sustainable Energy Reviews, Volume 60, Pages 1100-1113.
- [8] Pareek S., and Kaur, T., (2021), "Hybrid ANFIS-PID Based MPPT Controller for a Solar PV System with Electric Vehicle Load", IOP Conference Series. Materials Science and Engineering, Volume 1033, (1).
- [9] Elbaksawi O., (2019), "Design of Photovoltaic System Using Buck-Boost Converter based on MPPT with PID Controller." Universal Journal of Electrical and Electronic Engineering, Volume 6, Part 5, Pages 314 - 322.
- [10] Nasir, A., Rasool, I., Sibtain, D., (2020), "Adaptive Fractional Order PID Controller Based MPPT for PV Connected Grid System Under Changing Weather Conditions." J. Electr. Eng. Technol. Volume 16, Pages 2599–2610.
- [11] Nogueira, C.E.C., Bedin, J., Niedzialkoski, R.K., Souza, S.N.M., Neves, J.C.M., (2015), "Performance of monocrystalline and polycrystalline solar panels in a water pumping system in Brazil." Renewable and Sustainable Energy Reviews, Volume 51, Pages 1610-1616.
- [12] Lin, B.-R. and Wan, J.-F., (2008), "Analysis of the ZVS two-switch forward converter with synchronous current doubler rectifier." Int. J. Circ. Theor. Appl., Volume 36, Pages 311-325.
- [13] Silva, G.de.O., Hendrick, P., (2016), "Lead–acid batteries coupled with photovoltaics for increased electricity self-sufficiency in households." Applied Energy, Volume 178, Pages 856-867.
- [14] Moseley, P.T., Rand, D.A.J., Peters, K., (2015), "Enhancing the performance of lead–acid batteries with carbon – In pursuit of an understanding," Journal of Power Sources, Volume 295, Pages 268-274.