



Makale Künyesi / Citation: Tekkök Karaöz, B. (2023). Late Roman West Asia Minor Light Colored Ware from Granicus Surveyed Sites, SRMKA 5, 104-132.

LATE ROMAN WEST ASIA MINOR LIGHT COLORED WARE FROM GRANICUS SURVEYED SITES

GRANICUS YÜZEY ARAŞTIRMASI ALANLARINDAN ELE GEÇEN BATI ANADOLU GEÇ ROMA DÖNEMİ AÇIK RENKLİ SERAMİKLERİ

Billur TEKKÖK KARAÖZ *

Özet

Bu makale, Phocaeen Kırmızı Astarlılarının bazı formlarını taklit eden açık renkli hamurlu ve turuncu-kahverengi astarlı "Late Roman West Asia Minor Light Colored Ware" olarak tanımlanan bir grup geç Roma Dönemi astarlı seramiğinin kökeni hakkındaki tartışmaların bir derlemesidir. Granicus YüzeY Araştırması kapsamında kalan Geç Roma Dönemi yerleşimlerinde Foça Kırmızı Astarlıları grubu (LRC) formlarıyla birlikte bulunan ancak oran olarak daha fazla olan ve Karadeniz ve Marmara Bölgesi'nde yoğun dağılım gösteren bu grubun standart tabak, çanak, kandil ve sürahi örnekleri bu makalenin içeriğini oluşturur. Marmara ve Batı Anadolu kıyı kentlerinde (Smryna, Antandros, Ilion, Parion, Kyzikos, Constantinople) yoğunlaşan örnekler üzerinden bu seramik grubunun menşei konusunda yeni bir tartışma başlamış ve grubun dağılım modeline bağlı olarak yeni bir öneri ortaya atılmıştır. Yeni öneri, grubun dağılım modeline bağlı olarak kuzey Troas veya Marmara Bölgesi'dir.

Anahtar Kelimeler: Geç Roma Batı Anadolu Açık Astarlı Seramikleri, Kuzey Troad, Marmara Bölgesi.

Abstract

This article is a compilation of debates on the origin of a group of late Roman slipped pottery identified as the "Late Roman West Asia Minor Light Colored Ware" with a light-colored paste and an orange-brown slip that copies after some forms of the Phocaeen Red Slip ware.

The content of this article is composed of standard plates, bowls, oil lamps, and jugs of this group, which are found together with the forms of the Phocaeen Red Slip Ware (LRC) in the late Roman period settlements during the Granicus Survey, but which are more prevalent and show an intense distribution in the Black Sea and Marmara regions. A new debate on the origin of this ceramic group has started over the examples concentrated in the coastal cities of Marmara and Western Anatolia (Smryna,

* Prof. Dr., Başkent Üniversitesi, Güzel Sanatlar, Tasarım ve Mimarlık Fakültesi, Grafik ve Görsel Sanatlar Bölümü, Ankara, TÜRKİYE, E-Posta: tekkok@baskent.edu.tr Orcid ID: 0000-0001-8943-0215.

Author would like to thank Brian C.Rose for the permission to publish Granicus Survey Material, and special thanks go to Christina Kolb for drawings, Dr. Deniz Tamer and Ebru Kırkanlı for digitizing images and organizing plates, and Dr. Gabe Pizzorno for plotting locations on Google Earth Maps.



Antandros, Ilion, Parion, Kyzikos, Constantinople) and a new proposal has been put forward depending on the distribution model of the group and the new suggestion is northern Troad or Marmara region depending on the distribution pattern of the group.

Key Words: Late Roman West Asia Minor Light Colored Ware, Northern Troad, Marmara Region.

Introduction

Late Roman Light Colored Ware is a group of late Roman table wares produced from the late 4th century to the 7th century AD. The earliest publication of the ware by Waage in Antioch- on-the-Orontes publication¹, is followed by Hayes's classification of the group in Saraçhane excavations², In 1965 publication of Saraçhane Hayes classified this group as "Very Pale Ware with Orange Slip", in 1968 publication as "Light Colored Ware"³, in Late Roman Pottery publication as West Asia Minor Light-Coloured Ware⁴. He kept the same name for the group in his Athenian Agora publication⁵. Opait published a group from Roman Dobrudja and named as "Cnidian Fine Ware/Asia Minor Light Colored Ware"⁶. I classified them as "West Asia Minor Pale Ware" in 1996 and later as "Late Roman West Asia Minor Light Colored Ware" based on finds at Ilion and Granicus Surveys⁷. Ergürer and Domžalski have suggested the Troad region around Propontis or Pergamon region for production⁸. Laodikeia was suggested as another production centre due to the similarity to an ornamented plate series published by Hayes in Saraçhane⁹. Parion examples were sampled for chemical analysis; the results will clear clay provenance for the ware group¹⁰.

The place of production is still not known. Still, the ware group is well distributed in the northern Aegean, and Black Sea especially in the Dobrudja region, Marmara (Cyzicus), and northern Troad region, especially around Gönen.¹¹ Although Hayes suggested that this group was produced in the Knidos region, this study suggests a different localisation¹².

¹ Waage 1948, 42, RM5, Fig. 23. N.21.

² Hayes 1992, 7, 93-5, 100-2, 106, Fig. 1, 1-10, Fig. 31, 10.3, Fig. 32, 11.10, Fig. 33, 14.22-23, Fig. 37, 26.5, Fig. 41, 14.73-79, Fig. 44, 30.110, Fig. 50, 31.15-16.

³ Hayes et al. 1965, 235, Fig. D, no. 10; Hayes et al. 1968, 210-211, Fig. F, no. 75-77; Hayes 1992, 7, 94, Fig. 1, no. 1-10.

⁴ Hayes 1972, 408-410; Hayes et al. 1968, 211.

⁵ Hayes 2008, 91-92, Fig. 43, 1429-1455, Pl. 70, 1434-1444.

⁶ Opait 2004, 79.

⁷ Tekkök-Biçken 1996, 140, Fig. 87, G85; Heath-Tekkök 2007-2008, 76-77; Rose et al. 2007, 103, Cat. No. 108; 106, 107, 108, Cat. No. 119-123; 117.

⁸ Ergürer 2014, 175; Domžalski 2012, 338, 340, note 51.

⁹ Şimşek 2003, 416-418; Şimşek 2008, 133; for recent research See Oprüş 2022.

¹⁰ Ergürer -Akyol 2023 (in press).

¹¹ Oprüş 2022 (for decorated examples from Histria).

¹² Hayes et al. 1968, 211, footnote. 25; Hayes 1972, 408.

The findings from the Granicus surveyed region, especially in the inner region settlements suggest that the production centre is somewhere near the northern Troad region or Propontis region¹³. The examples unearthed in the new excavations in Istanbul and Saraçhane¹⁴, Yenikapı¹⁵, Cyzicus¹⁶, Ilion¹⁷, Parion¹⁸, Antandros¹⁹, Pergamon²⁰, and Allinaoi²¹, may support this view.

Although terminological differences define this group, it would be correct to call this group “Late Roman West Asia Minor Light Colored Ware” due to its fabric and slip colour²². The general characteristics of the ware group are well-fired surfaces and almost white to yellow fabric (10YR 7/4 to 8/4), and the slip surface is light orange (5YR 5/8 to 6/8) depending on firing. In some examples, the slip is brown due to stacking conditions in the oven. A homogeneous paste and surface are generally observed in Ilion (Troia) samples²³. In some examples, due to exposition and excessive heat, slip has left a metallic sheen on the surface. The most common forms in the 5th century AD are plates, simple dishes or bowls with ridging; more elaborate forms appeared in the 6th century AD. The bowls derive after Phocaeen Red Slip Ware Form 3 (b,c,h) varieties often carry triple rouletting on the rim; they are mainly dated to the third quarter of the 5th century AD to the 6th in Troy. In some examples, rouletting is done carelessly. The group introduces bowls with ledge rims, fine rouletting interior, and over the rim derived after Phocaeen Red Slip (LRC) Hayes Form 5b.²⁴

The dishes with champlévé ornamentation do not occur in surveyed regions.²⁵ Closed forms for table services (jar, jug and table jug) are common in the sites close to the Gönen region (Fig. 1). The region where the jug forms are most familiar is the Troad region. Examples seen in other settlements in the Mediterranean are plate and bowl-type forms where commercial sale is more convenient.

¹³ Ergürer 2014, 176, for map of distribution.

¹⁴ Hayes 1992, 7, 93–95, 100–102, 106, Fig. 1, 1-10; Fig. 31, 10.3; Fig. 32, 11.10; Fig. 33, 14.22–23, Fig. 37, 26.5; Fig. 41, 14.73–9, Fig. 44, 30.110; Fig. 50, 31.15–6.

¹⁵ Öztuncay 2007, 253, Kat.Y8.

¹⁶ Güneş 2010, 150, Pl. XVIII, Fig. 103–104, Pl. XIX, Fig.114.

¹⁷ Tekkök-Biçken 1996, 140, Fig. 87: G85; Heath – Tekkök 2007-2008, 76-77.

¹⁸ Ergürer 2012, 193-217; 2014, 175-191.

¹⁹ Aktaş 2020, 35-66.

²⁰ De Luca 1984, 9–10, 16, 21, 24, 31, 34–35, Taf. 8, 117,118; Taf. 10, 135–145; Taf. 1, 291–6; Taf. 25, 30.

²¹ Yeşilova 2007, 197, Cat. nos. 129, 152, 164–5, Pl. 33.

²² Ergürer 2014, 176.

²³ Heath – Tekkök 2007-2008, 76-77.

²⁴ Heath – Tekkök 2007-2008 <https://classics.uc.edu/troy/grbpottery/html/lr-lightcolored.html> 77/2022.

²⁵ Opriş 2022; Şimşek 2003; Şimşek 2008.

Discussion on Ceramics:

The plates with upright rim have close parallels in Antandros (1), copy after Phocaean Red Slip Ware (LRC), and the plate with slightly incurving rim (2) has no parallels copied after Hayes Phocaean Red Slip Ware Form 1. The plates with rilled rim form another form find parallels in Parion (3). The plates with ledge rims (4,5,6) presented in varieties form a common form found on coastal sites from Zeytinliada, Parion and Antandros. (6) may have been used as a reversible lid. The plates with the rouletting interior of the base (7, 8) often have shallow ring bases (9, 10, 11), some examples have a deep ridge around the base on the exterior (10, 11), (12) presented only with one example, has rouletting interior and a projecting ledge exterior around the base. The deep ridging exterior of the wall above the base is a common feature of 6th-century examples.

The flanged plates/bowls with deep ridgings exterior of the rim are common forms of the ware group from the 5th century to 6th Century AD (13-16), diameter ranges from 14 to 28 cm.

This group forms the most common and widely exported examples in the Aegean, especially in North Aegean, Constantinople, and coastal and inner sites in Dacia. The bowls with triple rouletting on the rim are a variety of group (17-22), some examples show carelessly applied rouletting (18), and some examples have no rouletting around the rim (23). The form derived after Phocaean Red Slip Ware Hayes Form 3, especially Hayes Form 3b, 3c and 3h.²⁶ They have shallow ring bases (24). The fabric contains heavy lime and silver mica. Most examples are well fired. Depending on the firing condition surface color ranges from pale orange to brown (between 5 YR 6/8 and 5/6). The slip applies well to clay, which is thicker in these examples. The examples from Parion, Kyzikos, Athens, Antandros and Priapos are dated; Parion examples are dated from well-dated contexts from the middle of the 5th century to the middle of the 6th century AD²⁷. The walls get heavier, the clay in later group is calcareous and the slip is of poorer quality.

Reversible lids/bowls are rare forms (25, 26) and only found in Zeytinliada (27) in Parion they are found in deposits after the middle of the 6th into the 7th Century AD.

Plates with upright ledge rim have deep turn marks on the exterior wall (28) or fine-combed rouletting on the interior and exterior and on the ledge rim (29).

²⁶ Hayes 1972, 329–33, 337–8, Fig. 67–8.

²⁷ Ergürer 2014, 181, under Form 5.

Bowl with upright rim forms a widely distributed example (31) in the Aegean and Mediterranean, mainly Thasos, Ilion, Antandros, and Benghazi. A simple variant is found in Parion (30) for regional consumption—another variant of the bowls with an upright ledge rim (32) with the combed rouletting exterior of the rim. The bowls of this group (30-32) are dated to the 5th Century AD.

The bowls with outturned ledge rim (33, 34) form another group datable to the 6th Century AD. They are presented in Parion and Zeytinliada.

The bowls with thickened rolled rim (35, 36, 37) often have traces of double line and deep cut rouletting exterior on the wall, and show traces of slip exterior wall. They are found in Zeytinliada and Antandros. The bowls with thickened ledge rims (38, 39) are another common form, (38) is from the 5th Century AD and (39) carries the form to the late 5th century AD with deep ridgings exterior of the wall. Both forms are well distributed in Athens, Constantinople, and Northern Aegean; Parion, and Priapos. The bowl with an inturned ledge rim and rouletting on the wall in and out (40) is not common but is dated with other finds to the 6th Century AD.

The bowl with inturned ledge rim (41) finds only parallels in İstanbul, Saraçhane and is dated to the late 6th to 7th Century AD. (42) represents a reversible bowl/lid found only in Granicus surveyed fields; the fabric is found in later forms of the ware group so dated to the 5th to 6th Century AD. (43) Another bowl form with heavy ledge rim is also rare in Parion and dated to the 6th to 7th Century AD. The bases (44, 45) are included in the catalogue (45) finds a parallel in Athens and are dated to the 5th to 6th Century AD. (44) has parallels in Marmaray, Constantinople's new excavations.²⁸

The typical features of the group are the jug forms with handles (46, 47) and deep ridgings on the neck (47, 53). The examples published in Antandros are dated from the 5th to 6th Century AD. (53) is dated to the 5th Century AD in Athens. The bases (49-51) have parallels in Antandros dating to the 5th Century AD. (48) jug, and (52) is a table jar dated to the 5th Century AD in Parion and Antandros. (54, 55, 56, 57) are mainly jug bases and find parallels in Athens and Antandros dated to the middle of the 5th Century AD. The lamps are not published elsewhere, only presented here (58-60). Lamps have preserved only bottoms, no trace of decoration on the discus. The fabrics are very similar to the 5th-century AD bowls.

²⁸ I have seen unpublished examples.

Conclusion:

The evidence from the Granicus surveyed region is new forms to a distinct production of Late Roman West Asia Minor Light Colored Ware. To avoid confusion with previous form definitions by Ergürer and Aktaş, new form numbers were given by the author in the Catalogue. So far, this Catalogue has the complete forms of the plain production series. The close examination of the fabrics and surface treatments led to the conclusion that the workshops that produced the ware had different treatments for the exported group, and the second quality ware was distributed regionally. During the 5th to 6th Century AD, Late Roman West Asia Minor Light Colored Ware competed with Phocaeen Red Slip Ware (LRC), especially in Propontis, Black Sea coastal sites, especially in Dacia, statistically the well-distributed forms are flanged bowls and plates. The jugs and table jars are aimed at regional distribution. The archaeometric analysis will prove the clay provenance of the ware group.²⁹

²⁹ Ergürer-Akyol 2023 (in press).

CATALOGUE:

1. Plate - Form 1a

Fig.2,8

40-5-3. PH. 2.1; est. D.rim 26; Th. 0.5. Preserving 1/10 of the rim. Upright, thickened rim. Yellow fabric, not preserving slip.

Parallels: Antandros (Aktas 2018, 224, 225, Cat. no 418; Aktaş 2020, 57, Drawing 2. Cat. no 33 - Form 6; 5th century AD - early 6th century AD)

Date: 5th century AD

2. Plate - Form 1b

Fig.2

33-5-11. PH. 2.8; est. D.rim 26; Th. 0.6. Preserving 1/16 of the rim. Pinkish buff fabric overfired, core grey, matte red slip.

No Parallels. Derived after Phocaeen Hayes Form 1 plates. Rare example.

Date: Late 4th to 5th century AD

3. Plate – Form 2

Fig.2

33-5-6. PH. 1.0; Th. 0.4. Preserving 1/10 of the rim. Rolled rim. Pinkish buff fabric, soft, with fine silver mica, fired grey at the core, preserving no slip.

Parallels: Parion (Ergürer 2014, 185, 188, 187, Pl. 6. 28 – Form 15; the second half of the 6th century and the first half of the 7th century)

Date: Second half of the 6th century and the first half of the 7th century AD.

4. Plate with ledge rim – Form 3a

Fig.2,8

42-3-12. PH. 1.0; est. D.rim 23; Th. 0.5. Preserving 1/8 of the rim. Ledge rim. Pale yellow fabric with thick orange slip in and out.

Parallels: Antandros (Aktaş 2020, Çiz. 1. 4 (late 4th century-5th century AD); Zeytinliada (Kavaz-Kındıgılı 2020, 263, Fig. 2, Kat. no 21 – Form 2; mid 4th century-early 6th century AD; Parion (Ergürer 2014, 178, Pl. 1, no. 6 – Form 2; late 4th century AD -early 6th century)

Date: Mid 4th century-early 6th century AD

5. Plate with ledge rim – Form 3b

Fig.2,8

40-5-14. PH. 1.7; est. D.rim 36; Th. 0.5. Preserving 1/20 of the rim. A single line of the rouletting interior of the rim. Yellow fabric, matte orange slip in and out.

Parallels: Antandros (Aktaş 2020, Çizim 1. Kat. no. 9 – Form 1C; late 4th century AD – first half of 5th century AD); Parion (Ergürer 2014, 179, 178, Pl. 1.5 – Form 2; late 4th century AD-early 6th century AD)

Date: Late 4th century AD-early 6th century AD

6. Plate with ledge rim – Form 3c

Fig.2,8

42-5-1. PH. 2.0; est. D.rim 27; Th.0.5. Preserving 1/20 of the rim. Pale yellow fabric overfired, with thick orange slip.

Parallels: Athenian Agora (Hayes 2008, Fig. 43.1434; Third quarter of 5th century)

Date: 6th century AD

7. Ring foot of a plate - Form 3

Fig.2,8

40-5-29. PH. 1.6; est. D.base 12; Th. 0.8. Preserving 1/6 of the base. Shallow ring base. Rouletting interior on base. Yellow fabric, matte orange slip in and out.

Parallels: Antandros (Aktas 2018, 211-212, Kat. no 383, 386, 387, 389, 390, 395; Aktaş 2020, 53-55, Drawing 1. Kat. no 16-21 – Form 1; 5th century AD); Parion (Ergürer 2014, 179, 178, Pl. 1, no. 4 – Form 2; late 4th century – early 6th century AD); Priapos (Rose et. al. 2007, 94, 143, Pl. 9, No. 123; late 6th century AD)

Date: 5th century AD

8. Ring foot of a plate - **Form 3**

Fig.2,8

46-1-13. PH. 2.5; est. D.base 16; Th. 0.5. Preserving 1/4 of the base. Rouletting interior. Yellow fabric fired grey.

Parallels: Antandros (Aktas 2020, 53-55, Drawing 1. Kat. no 16-21 – Form 1; 5th century AD)

Date: 5th century AD

9. Ring foot of a plate - **Form 3**

Fig.2,8

36-3-12. PH. 2.5; est. D.base 11; Th. 0.5. Preserving 1/4 of the base. Pale yellow fabric fired brown, brown slip in and out.

Parallels: Antandros (Aktas 2020, 53-55, Drawing 1. Kat. no 16-21 – Form 1; 5th century AD)

Date: 6th century AD

10. Ring foot of a plate - **Form 4**

Fig.2,8

42-4-20. PH. 2.7; est. D base 14; Th. 0.6. Preserving 1/6 of the base. Deep ridges on the wall where the base starts. Yellow fabric with matte orange slip.

Parallels: Athenian Agora (Hayes 2008, Fig. 43.1434; Third quarter of 5th century)

Date: 6th century AD

11. Ring foot of a plate- **Form 4**

Fig.2,8

33-6-3. PH. 2.3; est. D.base 11; Th. 0.5. Preserving 1/6 of the base. Deep grooves on the lower body on the outside. Pinkish buff fabric, soft, with fine silver mica, preserving red orange-red slip exterior.

Parallels: Antandros (Aktas 2020, 53-55, Çizim 1. Kat. no 16-21 – Form 1)

Date: 6th century AD

12. Ring foot of a plate- **Form 5**

Fig.2,8

46-1-14. PH. 3; est. D.base 13; Th. 0.5. Preserving 1/4 of the base. Ridges exterior on the wall. Rouletting interior. Yellow fabric fired grey, matte orange slip.

No parallels.

Date: 7th century AD

13. Plate, flanged - **Form 6**

Fig.3,8

33-6-2. PH. 2.5; est. D.rim 14; Th. 0.5. Preserving 1/10 rim. Deep ridges on the rim. Pinkish buff fabric, soft, with fine silver mica, preserving orange-red slip interior.

Parallels: Parion (Ergürer 2012, 203, 736, Pl. 182. Kat. no 438-444; Ergürer 2014, 181, 182, Pl. 3, no. 11-14; Ergürer 2015, 71, 72, 86, Res. 9. 59, 60 – Form 5; Mid.5th century AD – Mid. 6th century AD); Antandros (Aktas 2020, 56, 57, Drawing. 2. 28-30 – Form 3; Third quarter of 5th century AD to early 6th century AD); Zeytinliada (Kavaz-Kındığılı 2017, 168, Kat. no 7, 8; Kavaz-Kındığılı 2020, 263, 247, Fig. 2. Kat. no 25, 26 – Form 5; first half of 5th century AD- first half of 6th century AD); Athenian Agora (Hayes 2008, 250, Fig. 43. 1430-1432; Third quarter of 5th century AD to mid-6th century AD); Priapos (Rose et al. 2007, 89, 143, Pl. 9. 110; 5th century AD); Saraçhane (Hayes 1992, 94, 95, 154, Fig. 33. 14. 22; 526-527? AD); Topraichioi (Opait 1991a, 230, Pl. 41. 4,5); Aegyssus (Opait 1985, 155, 156, Fig. 2. 10);

Murighiol (Opait 1991b, 166, Pl. 45. 312, 313); Hayes 1972, 409, Fig. 92. 1; mid-5th century – early 7th century AD.

Date: Mid. 5th century AD – Mid. 6th century AD

14. Plate, flanged - **Form 6**

Fig.3,8

39-2-1. PH. 2.5; est. D. rim 18; Th. 0.5. Preserving 1/8 of the rim. Shallow ridges of rouletting around the rim. Light yellow fabric with matte thick orange slip preserved interior.

Parallels: Parion (Ergürer 2012, 203, 736, Pl. 182. Kat. no 438-444; Ergürer 2014, 181, 182, Pl. 3, no. 11-14; Ergürer 2015, 71, 72, 86, Res. 9. 59, 60 – Form 5; Mid.5th century AD – Mid. 6th century AD); Antandros (Aktaş 2020, 56, 57, Çiz. 2. 28-30 – Form 3; Third quarter of 5th century AD to early 6th century AD); Zeytinliada (Kavaz-Kındıgılı 2017, 168, Kat. no 7, 8; Kavaz-Kındıgılı 2020, 263, 247, Fig. 2. Kat. no 25, 26 – Form 5; first half of 5th century AD-first half of 6th century AD); Athenian Agora (Hayes 2008, 250, Fig. 43. 1430-1432; Third quarter of 5th century AD to mid-6th century AD); Priapos (Rose et al. 2007, 89, 143, Pl. 9. 110; 5th century AD); Saraçhane (Hayes 1992, 94, 95, 154, Fig. 33. 14. 22; 526-527? AD); Topraichioi (Opait 1991a, 230, Pl. 41. 4,5); Aegyssus (Opait 1985, 155, 156, Fig. 2. 10); Murighiol (Opait 1991b, 166, Pl. 45. 312, 313); Hayes 1972, 409, Fig. 92. 1; mid-5th century – early 7th century AD.

Date: Mid.5th century AD – Mid. 6th century AD

15. Plate, flanged - **Form 6**

Fig.3,8

40-5-8. PH. 3.2; est. D.rim 22; Th. 0.5. Preserving 1/8 of the rim. Grooved rouletting on the rim. Pinkish buff hard-fired fabric with thin orange-brown slip in and out. Another one is 40-5-54.

Parallels: Parion (Ergürer 2012, 203, 736, Pl. 182. Kat. no 438-444; Ergürer 2014, 181, 182, Pl. 3, no. 11-14; Ergürer 2015, 71, 72, 86, Res. 9. 59, 60 – Form 5; Mid.5th century AD – Mid. 6th century AD); Antandros (Aktaş 2020, 56, 57, Çiz. 2. 28-30 – Form 3; Third quarter of 5th century AD to early 6th century AD); Zeytinliada (Kavaz-Kındıgılı 2017, 168, Kat. no 7, 8; Kavaz-Kındıgılı 2020, 263, 247, Fig. 2. Kat. no 25, 26 – Form 5; first half of 5th century AD-first half of 6th century AD); Athenian Agora (Hayes 2008, 250, Fig. 43. 1430-1432; Third quarter of 5th century AD to mid-6th century AD); Priapos (Rose et al. 2007, 89, 143, Pl. 9. 110; 5th century AD); Saraçhane (Hayes 1992, 94, 95, 154, Fig. 33. 14. 22; 526-527? AD); Topraichioi (Opait 1991a, 230, Pl. 41. 4,5); Aegyssus (Opait 1985, 155, 156, Fig. 2. 10); Murighiol (Opait 1991b, 166, Pl. 45. 312, 313); Hayes 1972, 409, Fig. 92. 1; mid-5th century – early 7th century AD.

Date: Mid.5th century AD – Mid. 6th century AD

16. Plate, flanged - **Form 6**

Fig.3,8

37-2-2. PH. 2.6; est. D. rim 24; Th. 0.5. Preserving 1/16 of the rim. Traces of doubleline lined rouletting exterior on the wall. Light yellow fabric with matte thin orange slip.

Parallels: Parion (Ergürer 2012, 203, 736, Pl. 182. Kat. no 438-444; Ergürer 2014, 181, 182, Pl. 3, no. 11-14; Ergürer 2015, 71, 72, 86, Res. 9. 59, 60 – Form 5; Mid.5th century AD – Mid. 6th century AD); Antandros (Aktaş 2020, 56, 57, Çiz. 2. 28-30 – Form 3; Third quarter of 5th century AD to early 6th century AD); Zeytinliada (Kavaz-Kındıgılı 2017, 168, Kat. no 7, 8; Kavaz-Kındıgılı 2020, 263, 247, Fig. 2. Kat. no 25, 26 – Form 5; first half of 5th century AD-first half of 6th century AD); Athenian Agora (Hayes 2008, 250, Fig. 43. 1430-1432; Third quarter of 5th century AD to mid 6th century AD); Priapos (Rose et al. 2007, 89, 143, Pl. 9. 110; 5th century AD); Saraçhane (Hayes 1992, 94, 95, 154, Fig. 33. 14. 22; 526-527? AD); Topraichioi (Opait 1991a, 230, Pl. 41. 4,5); Aegyssus (Opait 1985, 155, 156, Fig. 2. 10);

Murighiol (Opait 1991b, 166, Pl. 45. 312, 313); Hayes 1972, 409, Fig. 92. 1; mid 5th century – early 7th century AD.

Date: Middle of the 5th century AD – Mid. 6th century AD

17. Plate, flanged - **Form 6**

Fig.3,8

37-2-1. PH. 3.2; est. D. rim 23; Th. 0.5. Preserving 1/8 of the rim. Traces of double lined and deep cut rouletting exterior on the wall. Light yellow fabric with matte, thin brown/orange slip preserved interior.

Parallels: Parion (Ergürer 2012, 203, 736, Pl. 182. Kat. no 438-444; Ergürer 2014, 181, 182, Pl. 3, no. 11-14; Ergürer 2015, 71, 72, 86, Res. 9. 59, 60 – Form 5; Mid.5th century AD – Mid. 6th century AD); Antandros (Aktaş 2020, 56, 57, Çizim 2. 28-30 – Form 3; Third quarter of 5th century AD to early 6th century AD); Zeytinliada (Kavaz-Kındıgılı 2017, 168, Kat. no 7, 8; Kavaz-Kındıgılı 2020, 263, 247, Fig. 2. Kat. no 25, 26 – Form 5; first half of 5th century AD-first half of 6th century AD); Athenian Agora (Hayes 2008, 250, Fig. 43. 1430-1432; Third quarter of 5th century AD to mid-6th century AD); Priapos (Rose et al. 2007, 89, 143, Pl. 9. 110; 5th century AD); Saraçhane (Hayes 1992, 94, 95, 154, Fig. 33. 14. 22; 526-527? AD); Topraichioi (Opait 1991a, 230, Pl. 41. 4,5); Aegyssus (Opait 1985, 155, 156, Fig. 2. 10); Murighiol (Opait 1991b, 166, Pl. 45. 312, 313); Hayes 1972, 409, Fig. 92. 1; mid-5th century – early 7th century AD.

Date: Mid.5th century AD – Mid. 6th century AD

18. Plate, flanged - **Form 6**

Fig.3,8

40.4.5. PH. 2.3; est. D. rim 24; Th. 0.5. Preserving 1/8 of the rim. Traces of double lined and deep cut rouletting exterior on the wall. Light yellow fabric with a matte, thin brown/orange slip-preserved interior.

Parallels: Parion (Ergürer 2012, 203, 736, Pl. 182. Kat. no 438-444; Ergürer 2014, 181, 182, Pl. 3, no. 11-14; Ergürer 2015, 71, 72, 86, Res. 9. 59, 60 – Form 5; Mid.5th century AD – Mid. 6th century AD); Antandros (Aktaş 2020, 56, 57, Çiz. 2. 28-30 – Form 3; Third quarter of 5th century AD to early 6th century AD); Zeytinliada (Kavaz-Kındıgılı 2017, 168, Kat. no 7, 8; Kavaz-Kındıgılı 2020, 263, 247, Fig. 2. Kat. no 25, 26 – Form 5; first half of 5th century AD-first half of 6th century AD); Athenian Agora (Hayes 2008, 250, Fig. 43. 1430-1432; Third quarter of 5th century AD to mid 6th century AD); Priapos (Rose et al. 2007, 89, 143, Pl. 9. 110; 5th century AD); Saraçhane (Hayes 1992, 94, 95, 154, Fig. 33. 14. 22; 526-527? AD); Topraichioi (Opait 1991a, 230, Pl. 41. 4,5); Aegyssus (Opait 1985, 155, 156, Fig. 2. 10); Murighiol (Opait 1991b, 166, Pl. 45. 312, 313); Hayes 1972, 409, Fig. 92. 1; mid 5th century – early 7th century AD.

Date: Mid.5th century AD – Mid. 6th century AD

19. Plate, flanged - **Form 6**

Fig.3,8

37-3-6. PH. 2.9; est. D. rim 25; Th. 0.6. Preserving 1/8 of the rim. The fine rouletting exterior on the wall. Traces of slip.

Parallels: Parion (Ergürer 2012, 203, 736, Pl. 182. Kat. no 438-444; Ergürer 2014, 181, 182, Pl. 3, no. 11-14; Ergürer 2015, 71, 72, 86, Res. 9. 59, 60 – Form 5; Mid.5th century AD – Mid. 6th century AD); Antandros (Aktaş 2020, 56, 57, Çiz. 2. 28-30 – Form 3; Third quarter of 5th century AD to early 6th century AD); Zeytinliada (Kavaz-Kındıgılı 2017, 168, Kat. no 7, 8; Kavaz-Kındıgılı 2020, 263, 247, Fig. 2. Kat. no 25, 26 – Form 5; first half of 5th century AD-first half of 6th century AD); Athenian Agora (Hayes 2008, 250, Fig. 43. 1430-1432; Third quarter of 5th century AD to mid-6th century AD); Priapos (Rose et al. 2007, 89, 143, Pl. 9. 110; 5th century AD); Saraçhane (Hayes 1992, 94, 95, 154, Fig. 33. 14. 22; 526-527? AD);

Topraichioi (Opait 1991a, 230, Pl. 41. 4,5); Aegyssus (Opait 1985, 155, 156, Fig. 2. 10); Murighiol (Opait 1991b, 166, Pl. 45. 312, 313); Hayes 1972, 409, Fig. 92. 1; mid 5th century – early 7th century AD.

Date: Mid.5th century AD – Mid. 6th century AD

20. Plate, flanged - **Form 6**

Fig.3,8

40-5-19. PH. 3.7; est. D.rim 24; Th. 0.5. Preserving 1/10 of the rim. Combed rouletting on the rim. Pinkish buff hard-fired fabric with thin brown slip in and out.

Parallels: Parion (Ergürer 2012, 203, 736, Pl. 182. Kat. no 438-444; Ergürer 2014, 181, 182, Pl. 3, no. 11-14; Ergürer 2015, 71, 72, 86, Res. 9. 59, 60 – Form 5; Mid.5th century AD – Mid. 6th century AD); Antandros (Aktaş 2020, 56, 57, Çiz. 2. 28-30 – Form 3; Third quarter of 5th century AD to early 6th century AD); Zeytinliada (Kavaz-Kındıgılı 2017, 168, Kat. no 7, 8; Kavaz-Kındıgılı 2020, 263, 247, Fig. 2. Kat. no 25, 26 – Form 5; first half of 5th century AD-first half of 6th century AD); Athenian Agora (Hayes 2008, 250, Fig. 43. 1430-1432; Third quarter of 5th century AD to mid-6th century AD); Priapos (Rose et al. 2007, 89, 143, Pl. 9. 110; 5th century AD); Saraçhane (Hayes 1992, 94, 95, 154, Fig. 33. 14. 22; 526-527? AD); Topraichioi (Opait 1991a, 230, Pl. 41. 4,5); Aegyssus (Opait 1985, 155, 156, Fig. 2. 10); Murighiol (Opait 1991b, 166, Pl. 45. 312, 313); Hayes 1972, 409, Fig. 92. 1; mid-5th century – early 7th century AD.

Date: Mid.5th century AD – Mid. 6th century AD

21. Plate, flanged - **Form 6**

Fig.3,8

40-5-18. PH. 3.2; est. D.rim 22; Th. 0.4. Preserving 1/10 of the rim. Combed shallow rouletting on the rim. Yellow fabric with thin orange slip in and out.

Parallels: Parion (Ergürer 2012, 203, 736, Pl. 182. Kat. no 438-444; Ergürer 2014, 181, 182, Pl. 3, no. 11-14; Ergürer 2015, 71, 72, 86, Res. 9. 59, 60 – Form 5; Mid.5th century AD – Mid. 6th century AD); Antandros (Aktaş 2020, 56, 57, Çiz. 2. 28-30 – Form 3; Third quarter of 5th century AD to early 6th century AD); Zeytinliada (Kavaz-Kındıgılı 2017, 168, Kat. no 7, 8; Kavaz-Kındıgılı 2020, 263, 247, Fig. 2. Kat. no 25, 26 – Form 5; first half of 5th century AD-first half of 6th century AD); Athenian Agora (Hayes 2008, 250, Fig. 43. 1430-1432; Third quarter of 5th century AD to mid-6th century AD); Priapos (Rose et al. 2007, 89, 143, Pl. 9. 110; 5th century AD); Saraçhane (Hayes 1992, 94, 95, 154, Fig. 33. 14. 22; 526-527? AD); Topraichioi (Opait 1991a, 230, Pl. 41. 4,5); Aegyssus (Opait 1985, 155, 156, Fig. 2. 10); Murighiol (Opait 1991b, 166, Pl. 45. 312, 313); Hayes 1972, 409, Fig. 92. 1; mid 5th century – early 7th century AD.

Date: Mid.5th century AD – Mid. 6th century AD

22. Plate, flanged - **Form 6**

Fig.3,8

42.5.3 PH. 2.0; est. D.rim 25; Th. 0.4.

Parallels: Parion (Ergürer 2012, 203, 736, Pl. 182. Kat. no 438-444; Ergürer 2014, 181, 182, Pl. 3, no. 11-14; Ergürer 2015, 71, 72, 86, Res. 9. 59, 60 – Form 5; Mid.5th century AD – Mid. 6th century AD); Antandros (Aktaş 2020, 56, 57, Drawing. 2. 28-30 – Form 3; Third quarter of 5th century AD to early 6th century AD); Zeytinliada (Kavaz-Kındıgılı 2017, 168, Kat. no 7, 8; Kavaz-Kındıgılı 2020, 263, 247, Fig. 2. Kat. no 25, 26 – Form 5; first half of 5th century AD-first half of 6th century AD); Athenian Agora (Hayes 2008, 250, Fig. 43. 1430-1432; Third quarter of 5th century AD to mid-6th century AD); Priapos (Rose et al. 2007, 89, 143, Pl. 9. 110; 5th century AD); Saraçhane (Hayes 1992, 94, 95, 154, Fig. 33. 14. 22; 526-527? AD); Topraichioi (Opait 1991a, 230, Pl. 41. 4,5); Aegyssus (Opait 1985, 155, 156, Fig. 2. 10);

Murighiol (Opait 1991b, 166, Pl. 45. 312, 313); Hayes 1972, 409, Fig. 92. 1; mid-5th century – early 7th century AD.

Date: Mid.5th century AD – Mid. 6th century AD

23. Plate, flanged - **Form 6**

Fig.3,8

42.5.5 PH. 1.8; est. D.rim 28; Th. 0.6.

Parallels: Parion (Ergürer 2012, 203, 736, Pl. 182. Kat. no 438-444; Ergürer 2014, 181, 182, Pl. 3, no. 11-14; Ergürer 2015, 71, 72, 86, Res. 9. 59, 60 – Form 5; Mid.5th century AD – Mid. 6th century AD); Antandros (Aktas 2020, 56, 57, Çiz. 2. 28-30 – Form 3; Third quarter of 5th century AD to early 6th century AD); Zeytinliada (Kavaz-Kındıgılı 2017, 168, Kat. no 7, 8; Kavaz-Kındıgılı 2020, 263, 247, Fig. 2. Kat. no 25, 26 – Form 5; first half of 5th century AD– first half of 6th century AD); Athenian Agora (Hayes 2008, 250, Fig. 43. 1430-1432; Third quarter of 5th century AD to mid-6th century AD); Priapos (Rose et al. 2007, 89, 143, Pl. 9. 110; 5th century AD); Saraçhane (Hayes 1992, 94, 95, 154, Fig. 33. 14. 22; 526-527? AD); Topraichioi (Opait 1991a, 230, Pl. 41. 4,5); Aegyssus (Opait 1985, 155, 156, Fig. 2. 10); Murighiol (Opait 1991b, 166, Pl. 45. 312, 313); Hayes 1972, 409, Fig. 92. 1; mid-5th century – early 7th century AD.

Date: Mid.5th century AD – Mid. 6th century AD

24. Ring foot of a plate, flanged- **Form 6**

Fig.3,8

16-4-2. PH. 2.1; est. D.base 13; Th. 0.5. Preserving 1/6 of the base. Pale yellow fabric, preserving no slip.

Parallels: Antandros (Aktas 2018, 211-212, Kat. no 383, 386, 387, 389, 390, 395; Aktas 2020, 53-55, Çizim 1. Kat. no 16-21 – Form 1; 5th century AD); Parion (Ergürer 2014, 179, 178, Pl. 1, no. 4 – Form 2; late 4th century – early 6th century AD); Priapos (Rose et al. 2007, 94, 143, Pl. 9, No. 123; late 6th century AD)

Date: Late 6th century AD

25. Bowl, lid - **Form 7a**

Fig.4,8

40.4.7. PH. 2.3; est. D.rim 17; Th.0.5. Preserving less than 1/10 rim. Pale yellow fabric, matte poor orange slip.

Parallels: Zeytinliada (Kavaz-Kındıgılı 2020, 263, Fig. 2, Kat. No. 31 – Form 12; second half of 6th century AD – first half of 7th century AD)

Date: 6th century AD

26. Bowl, lid - - **Form 7b**

Fig.4,8

46-1-9. PH. 2.5; est. D.rim 34; Th. 0.6. Preserving 1/10 of the rim. Ridges on the wall. Yellow fabric not preserving slip.

Parallels: Zeytinliada (Kavaz-Kındıgılı 2020, 264, Fig. 3. Kat. no. 34 – Form 13; first half of 6th century AD – first half of 7th century AD)

Date: First half of 6th century AD – first half of 7th century AD

27. Bowl, lid - **Form 7c**

Fig.4,8

42-4-14. PH. 3; est. D rim 28; Th. 0.5. Preserving 1/10 of the rim. Ledge rim. Yellow fabric, traces of orange slip.

Parallels: Parion (Ergürer 2014, 183, 185, 186, Pl. 5. 22 – Form 11; Second half of 6th century AD)

Date: Second half of the 6th century AD

28. Bowl - **Form 8a**

Fig.4,8

40.4.6. PH. 2; est. D.rim 20; Th.0.6. Preserving 1/10 of the rim. Pale yellow fabric with bright matte orange slip. Upright ledge rim, deep ridgings exterior of the wall.

Parallels: Antandros (Aktaş 2018, 215-216, Kat. no 401; Aktaş 2020, 55, Drawing 1. Kat. No. 23- Form 2A; 2nd quarter of 5th century AD) Antandros (Açar 2017, 118, Kat. no 67 – Form 6; 3rd quarter of 5th century AD)

Date: Second quarter of 5th century AD

29. Bowl - **Form 8b**

Fig.4,8

40-5-13. PH. 3.0; est. D.rim 20; Th. 0.5. Preserving 1/8 of the rim. Upright ledge rim with combed rouletting on wall interior, exterior, and rim. Pale pinkish fabric with thick orange slip preserved in and out.

Parallels: Parion (Ergürer 2014, 183, 184, Pl. 4. 18 – Form 8 – First half of 6th century AD)

Date: First half of 6th century AD

30. Bowl with upright ledge rim – **Form 9a**

Fig.4,9

40-5-7. PH. 3.7; est. D.rim 24; Th. 0.6. Preserving 1/10 of the rim. Upright, thickened rim. Yellow fabric with thick orange slip preserved in and out.

Parallels: Parion (Ergürer 2014, 177, 179, 178, Pl. 1. 2, Form 1 (The late 4th and late 5th century AD)

Date: 5th Century AD

31. Bowl with upright ledge rim – **Form 9b**

Fig.4,9

40-5-27. PH. 3.2; est. D.rim 27; Th. 0.6. Preserving 1/10 of the rim. Ridges exterior on the wall. Yellow fabric with thick orange slip preserved in and out.

Parallels: Antandros (Aktaş 2018, 216-218, Kat. no 406; Aktaş 2020, 55, 56, Fig. 5. Kat. no 25 – Form 2B; 3rd quarter of 5th century AD) Antandros (Açar 2017, 118,119, Kat. no 68 – Form 6; 3rd quarter of 5th century AD); Troia (Tekkök-Biçken 1996, 140, 273, Fig. 87, G85 –337-350 AD); Thasos (Abadie-Reynal – Sodini 1992, 33, Fig. 13. CF182); Benghazi (Kenrick 1985, 404, Fig. 75. 722.2)

Date: 3rd quarter of 5th century AD

32. Bowl with upright ledge rim – **Form 10a**

Fig.4,9

40-5-6. PH. 2.4; est. D.rim 19; Th. 0.5. Preserving 1/8 of the rim. Upright rim with combed rouletting on the rim. Yellow fabric with thick orange slip preserved in and out.

Parallels: Antandros (Aktaş 2020, Drawing 1. Kat. no. 22 – Form 2; second half of 5th century AD)

Date: Second half of 5th century AD

33. Bowl with out turned ledge rim - **Form 10b**

Fig.4

33.5-1. PH. 2.2; est. D.rim 21; Th.0.5. Preserving 1/6 of the rim. Yellow fine fabric with shiny orange slip, well fired.

Parallels: Zeytinliada (Kavaz-Kındığılı 2020, 248, 249, 264, Fig. 3, Kat. No. 36 – Form 14; 1st half of 5th century AD – 1st half of 7th century AD)

Date: 6th century AD

34. Bowl with out turned ledge rim - **Form 10c**

Fig.4,9

42-3-14. PH. 2.5; est. D.rim 21; Th. 0.5. Preserving 1/8 of the rim. Ledge rim. Pale yellow fabric traces of matte orange slip in and out.

Parallels: Parion (Ergürer 2014, 183, 185, 186, Pl. 5. 21 – Form 11; 2nd half of 6th century AD)

Date: Second half of 6th century AD

35. Bowl with thickened and rolled rim - **Form 11** **Fig.5,9**

37-2-3. PH. 3.1; est. D.rim 19; Th. 0.4. Preserving 1/8 of the rim. Deep ridge on the wall. Pale buff fabric, preserving orange-brown slip interior.

Parallels: Antandros (Aktaş 2020, 56, Fig. 5, Kat. no 27 – Form 2C; 5th century AD)

Date: 5th and 6th century AD

36. Bowl with thickened and rolled rim - **Form 11** **Fig.5,9**

37-2-4. PH. 1.5; est. D.rim 20; Th. 0.4. Preserving 1/16 of the rim. Deep ridge exterior on the wall. Pale buff fabric, preserving orange-brown slip on the exterior.

Parallels: Zeytinliada (Kavaz-Kındıgılı 2020, 264, Fig. 3, Kat. No. 35 – Form 14; first half of 5th-century AD-first half of 7th century AD)

Date: 5th and 6th century AD

37. Bowl with thickened and rolled rim – **Form 11** **Fig.5,9**

37-2-24. PH. 3.8; est. D. rim 18; Th. 0.5. Preserving 1/8 of the rim. Traces of doubleline lined and deep cut rouletting exterior on the wall. Light yellow fabric, traces of slip exterior wall.

Parallels: Zeytinliada (Kavaz-Kındıgılı 2020, 264, Fig. 3, Kat. No. 35 – Form 14; first half of 5th-century AD-first half of 7th century AD)

Date: 5th and 6th century AD

38. Bowl with ledge rim - **Form 12** **Fig.5,9**

40-5-5. PH. 2.2; est. D.rim 26; Th. 0.5. Preserving 1/8 of the rim. Ledge rim. Ridges exterior on the wall. Yellow fabric with thick orange slip preserved in and out.

Parallels: Parion (Ergürer 2014, 183, 184, Pl. 4, no.16– Form 6; 2nd half of 5th century AD);

Priapos (Rose et al. 2007, 93, Pl. 9, No 119,120; second-third quarter of fifth century AD);

Athenian Agora (Hayes 2008, Fig. 43, 1441; ca. Third quarter of 5th century AD); Antandros

(Aktaş 2020, 56, Drawing 1, Kat. No. 26 – Form 2B; Third quarter of 5th century AD).

Date: 5th century AD.

39. Bowl with ledge rim - **Form 12** **Fig.5,9**

40-5-15. PH. 4.5; est. D.rim 19; Th. 0.4. Preserving 1/6 of the rim. Ledge rim. Ridges exterior on the wall below the rim. Yellow fabric with thick orange slip preserved in and out.

Parallels: Saraçhane (Hayes 1992, 6, Fig. 1.7); Athenian Agora (Hayes 2008, 251, Fig. 43, 1442; ca. Third quarter of 5th century AD); Parion (Ergürer 2014, 183, 184, Pl. 4. No. 15 –

Form 6; 2nd half of 5th century AD); Priapos (Rose et al. 2007, 93, 143, Pl. 9, No 120, second quarter of fifth century AD).

Date: 5th and 6th Century AD

40. Bowl – **Form 13** **Fig.5,9**

46-1-8. PH. 3; est. D. rim 14; Th. 0.6. Preserving 1/6 of the rim. Rouletting on the wall in and out. Yellow fabric, preserving orange slip interior.

Parallels:

Date: 6th century AD

41. Bowl - **Form 14**

Fig.5,9

37-3-2. PH. 2.4; est. D. rim 24; Th. 0.6. Preserving 1/8 of the rim. Ledge rim. Yellow fabric, not preserving slip.

Parallels: Saraçhane (Hayes 1992, 8, 6, Fig 1.8; Late 6th to early 7th century AD)

Date: Late 6th to early 7th Century AD

42. Bowl/Lid – **Form 15**

Fig.5,9

42-4-13. PH. 2.2; est. D. rim 27; Th. 0.5. Preserving 1/8 of the rim. Yellow fabric fired grey traces of orange slip.

Parallels:

Date: 5th -6th Century AD

43. Bowl – **Form 16**

Fig.5,9

42-4-15. PH. 3; est. D. rim 21; Th. 0.7. Preserving 1/10 of the rim. Ledge rim. Yellow fabric, traces of orange slip exterior.

Parallels: Parion (Ergürer 2014, 183, 185, 188, 187, Pl. 6. 30 – Form 15; 2nd half of the 6th century – the 1st half of the 7th century AD)

Date: 6th Century AD

44. Ring the foot of a bowl.

Fig.5,9

40-5-21. PH. 2.2; est. D.base 7; Th. 0.5. Preserving 1/4 of the base. High ring base. Rouletting interior on base. Yellow fabric fired grey at the core, matte brown slip in and out.

Parallels:

Date: 5th and 6th Century AD

45. Ring the foot of a bowl.

Fig.5,9

42-4-19. PH. 2.7; est. D base 11; Th. 0.6. Preserving 1/4 of the base. Shallow ring base. Yellow fabric with matte orange slip.

Parallels: Athenian Agora (Hayes 2008, 251, Fig. 43. 1448; mid. to 3rd quarter -5th century AD)

Date: 5th and 6th Century AD

46. Jug - **Form 17**

Fig.6,9

39-1-1. PH. 1.7; est. D. rim 6.0; Th. 0.5. Preserving 1/6 of rim and handle. Light yellow fabric with matte thick orange slip.

Parallels: Antandros (Aktaş 2018, 231, Kat. no 431; Aktaş 2020, 59, Drawing 2. 41 – Form 11; second half of the 4th century AD – beginning of the 6th century AD)

Date: 6th century AD

47. Jug - **Form 18**

Fig.6,9

40.5.9. PH. 2.2; est. D.rim 8; Th. 0.5. Preserving only 1/6 of the rim with a trace of the handle. Cut a groove on the neck. Yellow fabric with matte thin orange slip.

Parallels: Antandros (Aktaş 2018, 233, Kat. no 436; Aktaş 2020, 60, Drawing 2. 44 – Form 11; 5th century AD)

Date: 5th century AD

48. Jug - **Form 19**

Fig.6,9

40.4.4. PH. 2.5; est. D.rim 23; Th. 0.5. Preserving only 1/6 of the rim with deep grooves on the rim. Yellow fabric with matte thin orange slip.

Parallels: Antandros (Aktaş 2018, 231, Kat. no 433; Aktaş 2020, 59, Drawing 2. 42 – Form 11; 4th - 5th century AD)

Date: 5th century AD

49. Jug - **Form 18**

Fig.6,9

35-1-20. PH. 2.1; est. D base 6.0; Th. 0.5. Preserving 1/4 of the base. Shallow ring base. Pale fabric with thick orange slip.

Parallels: Antandros (Aktaş 2018, 233, Kat. no 436; Aktaş 2020, 60, Drawing 2. 44 – Form 11; 5th century AD)

Date: 5th century AD

50. Jug - **Form 18**

Fig.6,9

40-5-61. PH. 1.8; est. D.base 4.4; Th. 0.5. Preserving almost the whole base. Yellow fabric with matte orange out.

Parallels: Antandros (Aktaş 2018, 233, Kat. no 436; Aktaş 2020, 60, Drawing 2. 44 – Form 11; 5th century AD)

Date: 5th century AD

51. Jug - **Form 18**

Fig.6,9

42-3-27. PH. 2.2; est. D.base 5.8; Th. 0.5. Preserving 1/2 of base. Ring base. Pale yellow fabric traces of matte orange slip out.

Parallels: Antandros (Aktaş 2018, 233, Kat. no 436; Aktaş 2020, 60, Drawing 2. 44 – Form 11; 5th century AD)

Date: 5th century AD

52. Table jar - **Form 20**

Fig.6,9

33-6-4. PH. 2.1; est. D.base 10; Th. 0.5. Preserving 1/4 of the base. Deep ridges exterior of the base. Yellow fabric, soft, with fine silver mica, traces of orange slip exterior on the wall.

Parallels: Antandros (Aktaş 2018, 228, 229, Kat. no 426; Aktaş 2020, 59, Drawing 2. 39 – Form 10; 2nd half of 5th century AD), Parion (Ergürer 2012, 212, 516, Kat. no. 465; Ergürer 2014, 188, 187, Pl. 6. 32 – Form 16; 2nd half of 5th century AD).

Date: 2nd half of 5th century AD

53. Jug - **Form 21**

Fig.6,9

42-2-10. PH. 3.5; est. D.neck 3.6; Th. 0.5. Preserving 1/3 of the neck with the handle. Deep ridges on the neck, with strap handle. Pale yellow fabric with matte orange slip.

Parallels: Antandros (Aktaş 2018, 234, Kat. no 440; Aktaş 2020, 60, Drawing 2. 45 – Form 11; 3rd quarter of 5th century AD); Athenian Agora (Hayes 2008, 252, Fig. 43. 1451, 1452; ca 460-480 AD).

Date: 2nd half of 5th century AD

54. Jug - **Form 21**

Fig.6,9

40-5-58. PH. 3.2; est. D.base 4; Th. 0.4. Preserving the whole base. The base scraped off. Yellow fabric, the trace of orange slip exterior on the wall.

Parallels: Antandros (Aktaş 2018, 234, Kat. no 440; Aktaş 2020, 60, Drawing 2. 45 – Form 11; 3rd quarter of 5th century AD); Athenian Agora (Hayes 2008, 252, Fig. 43. 1451, 1452; ca 460-480 AD).

Date: 2nd half of 5th century AD

55. Jug - Form 22

Fig.6,9

35-1-19. PH. 3.1; est. D base 7.0; Th. 0.4. Preserving 1/6 of the base. Sits on a shallow recessed base. Pale fabric with matte orange slip.

Parallels: Athenian Agora (Hayes 2008, 252, Fig. 43. 1454; ca 460-480 AD).

Date: 2nd half of 5th century AD

56. Jug - Form 22

Fig.6,9

35-1-24. PH. 2.5; est. D base 4.0; Th. 0.7. Preserving 1/4 of base. Deep cut under base. Pinkish buff fabric fired grey at core, self-slip.

Parallels: Athenian Agora (Hayes 2008, 252, Fig. 43. 1454; ca 460-480 AD).

Date: 2nd half of 5th century AD

57. Jug - Form 22

Fig.6,9

44-2-14. PH 2; est. D.base 8; Th. 0.5. Preserving 1/4 of the base. Fired grey traces of brown slip under the base. Overfired.

Parallels: Athenian Agora (Hayes 2008, 252, Fig. 43. 1454; ca 460-480 AD).

Date: 2nd half of 5th century AD

58. Lamp - Form 23

Fig.7,9

35-1-21. PH.1.5; est. D base 4.5; L. 11; Th. 0.5. Preserving 1/4 of the base, trace of a handle. Pale fabric with thick orange slip.

No published parallels.

59. Lamp - Form 23

Fig.7,9

44-2.1. PH. 1.9; est. D.base 5.2; L.9.0; Th. 0.5. Preserving 1/2 of base. Moulded in two pieces. Yellow fabric with matte orange slip.

No published parallels.

60. Lamp - Form 23

Fig.7, 9

44-2.2. PH. 2.7; est. D.base 6.5; L. 8.3; Th. 0.5. Preserving 1/2 of base. Moulded in two pieces. No decoration. Yellow fabric with matte orange slip.

No published parallels.

REFERENCES

Abadie-Reynal – Sodini 1992

Abadie-Reynal, C., & Sodini, J.-P. (1992). *La céramique paléochrétienne de Thasos (Alikı, Delkos, fouilles anciennes)*. Etudes Thasiennes XIII, Paris.

Açar 2017

Açar, E. (2017). *Antandros Nekropolü Geç Roma Yerleşmesi*. (Yayınlanmamış Yüksek Lisans Tezi), Ege Üniversitesi, Sosyal Bilimler Enstitüsü, İzmir.

Aktaş 2018

Aktaş, R. (2018). *Antandros Yamaç Ev Sektörü Roma Dönemi Seramikleri*. (Yayınlanmamış Yüksek Lisans Tezi), Ege Üniversitesi, Sosyal Bilimler Enstitüsü, İzmir.

Aktaş 2020

Aktaş, R. (2020). “Antandros Yamaç Ev Sektörü’nde Ele Geçen Açık Renkli Seramikler”, V. Keleş (Ed.), *Propontis ve Çevre Kültürleri: Parion Studies III*, İstanbul, 35-75.

Domzalski 2012

Domzalski, K. (2012). “At the Crossroads of Trade Routes: Terra Sigillata, Red Slip Wares and Related Fine Pottery from the Polish Excavations in Ptolemais (2002-2009)”, J. Zelazowski (Ed.), *Ptolemais in Cyrenaica: Studies in Memory of Tomasz Mikocki*, Warsaw, 319-345.

Ergürer – Akyol 2023

Ergürer, H. E., & Akyol, A. A. (in progress). *Parion Geç Roma Açık Renk Astarlıları Arkeometrik Analiz Sonuçları*.

Ergürer 2015

Ergürer, H. E. (2015). “Parion, Agora ve Dükkanlarında Ele Geçen Sigillatalar ve Kırmızı Astarlı Seramikler”, C. Başaran & V. Keleş (Eds.), *Parion Kazıları 10. Yıl Armağanı*, Ankara, 49-86.

Ergürer 2014

Ergürer, H. E. (2014). “Late Roman Light Coloured Ware from Parion”, M. Meyza & K. Domzalski (Eds.), *Late Hellenistic to Mediaeval Fine Wares of the Aegean Coast of Anatolia, Their Production, Imitation and Use*, Warsaw, 175-219.

Ergürer 2012

Ergürer, H. E. (2012). *Parion Roma Seramikleri*. (Yayınlanmamış Doktora Tezi), Atatürk Üniversitesi, Sosyal Bilimler Enstitüsü, Klasik Arkeoloji Anabilim Dalı, Erzurum.

De Luca 1984

De Luca, G. (1984). *Das Asklepieion, 4. Teil: Via Tecta und Hallenstrasse die Funde*. Berlin: Walter de Gruyter.

Güneş 2010

Güneş, F. (2010). Kyzikos Antik Kenti 2006–2007 Kazı Dönemi Seramik Buluntuları. (Yayınlanmamış Yüksek Lisans Tezi), Atatürk Üniversitesi, Sosyal Bilimler Enstitüsü, Erzurum.

Hayes et al. 1965

Hayes, J. W., Harrison, R. M., & Fıratlı, N. (1965). Excavations at Saraçhane in Istanbul: First Preliminary Report. *Dumbarton Oaks Papers*, 19, 230-236.

Hayes et al. 1968

Hayes, J. W., Harrison, R. M., & Fıratlı, N. (1968). Excavations at Saraçhane in Istanbul: Fifth Preliminary Report, with a Contribution on A Seventh-Century Pottery Group. *Dumbarton Oaks Papers*, 22, 195-216.

Hayes 1972

Hayes, J. W. (1972). *Late Roman Pottery*. London: British School at Rome.

Hayes 1992

Hayes, J. W. (1992). *Excavations at Saraçhane, Istanbul, Vol. 2*. Princeton: Princeton University Press.

Hayes 2008

Hayes, J. W. (2008). *The Athenian Agora, Volume XXXII: Roman Pottery: Fine-ware Imports*. Princeton: American School of Classical Studies at Athens.

Heath – Tekkök 2007-2008

Heath, S., & Tekkök, B. (2008). *Greek, Roman and Byzantine Pottery at Ilion. (Troia 2007-2008 Project Troia)*. Retrieved from <https://classics.uc.edu/troy/grbpottery/html/lr-lightcolored.html>

Kavaz-Kındıgılı 2017

Kavaz-Kındıgılı, B. (2017). Zeytinliada Light Colored (Açık Renkli) Geç Roma Seramikleri. *Atatürk Üniversitesi Güzel Sanatlar Enstitüsü Dergisi*, 38, 151-176.

Kavaz-Kındıgılı 2020

Kavaz-Kındıgılı, B. (2020). Zeytinliada Kırmızı Astarlı Seramikleri. *Atatürk Üniversitesi Sosyal Bilimler Enstitüsü Dergisi*, 24(Aralık Özel Sayı), 239-264.

Kenrick 1985

Kenrick, P. M. (1985). *Excavation at Sidi Khrebish Benghazi (Berenice)*. Volume III, 1. *Supplements to Libya Antiqua*, 5. Tripoli.

Opait 1985

Opait, A. (1985). Einige Beobachtungen zur spätrömischen Keramik mit rötem Überzug. *Dacia*, 29, 153-163.

Opait 1991a

Opait, A. (1991a). "Ceramica" in A. Opait, M. Zahariade, Gh. Poenaru-Bordea, C. Opait, "Fortificatia și așezarea romana tirzie de la Babadag-Topraichioi", *Peuce* 10, 211-260.

Opait 1991b

Opait, A. (1991b). Ceramica din aşezarea și cetatea de la Independenta (Murighiol), sec. V i.e.n.-VII e.n. Peuce, 10, 133-182.

Opait 2004

Opait, A. (2004). Local and Imported Ceramics in the Roman Province of Scythia (4th-6th Centuries AD). BAR International Series 1274. Oxford.

Opriş 2022

Opriş, I. C. (2022). Adding to John W. Hayes's Late Roman Pottery. Late Roman Light-Colored Wares with champlevé decoration from Histria revisited. Cercetări Arheologice, 29, 287-316.

Öztuncay 2007

Öztuncay, B. (2007). Gün Işığında İstanbul'un 8000 Bin yılı Marmaray Metro Sultanahmet Kazıları. İstanbul: Vehbi Koç Yayınları.

Rose et al. 2007

Rose, C. B., Tekkök, B., & Körpe, R. (2007). Granicus River Valley Survey Project, 2004-2005. Studia Troica, 17, 65-150.

Şimşek 2003

Şimşek, C. (2003). "Laodikea Antik Kentinden Haç Baskılı Tabaklar", III. Uluslararası Eskişehir Pişmiş Toprak Sempozyumu, (16-30 Haziran 2003) Eskişehir: Tepebaşı Belediyesi, 411-423.

Şimşek 2008

Şimşek, C. (2008). Laodikeia'dan Kazıma-Kabartılı Tabaklar. Arkeoloji Dergisi, 11(2008/1), 129-146.

Tekkök-Biçken 1996

Tekkök-Biçken, B. (1996). The Hellenistic and Roman Pottery from Troia: Second Century B.C. to Sixth Century A.D. (Unpublished doctoral dissertation), University of Missouri-Columbia, University of Michigan Microfilms.

Waage 1948

Waage, F. O. (1948). Hellenistic and Roman Tableware of North Syria, Antioch on the Orontes, IV, i: Ceramics and Islamic Coins. Princeton.

Yeşilova 2007

Yeşilova, H. (2007). Alliano Antik Kenti Ilıcası Erken Bizans Dönemi Seramikleri (Kırmızı Astarlı Kaplar ve Günlük Kullanım Kapları, 1999-2005). (Yayınlanmamış Yüksek Lisans Tezi), Hacettepe Üniversitesi, Sosyal Bilimler Enstitüsü, Ankara.

FIGURES

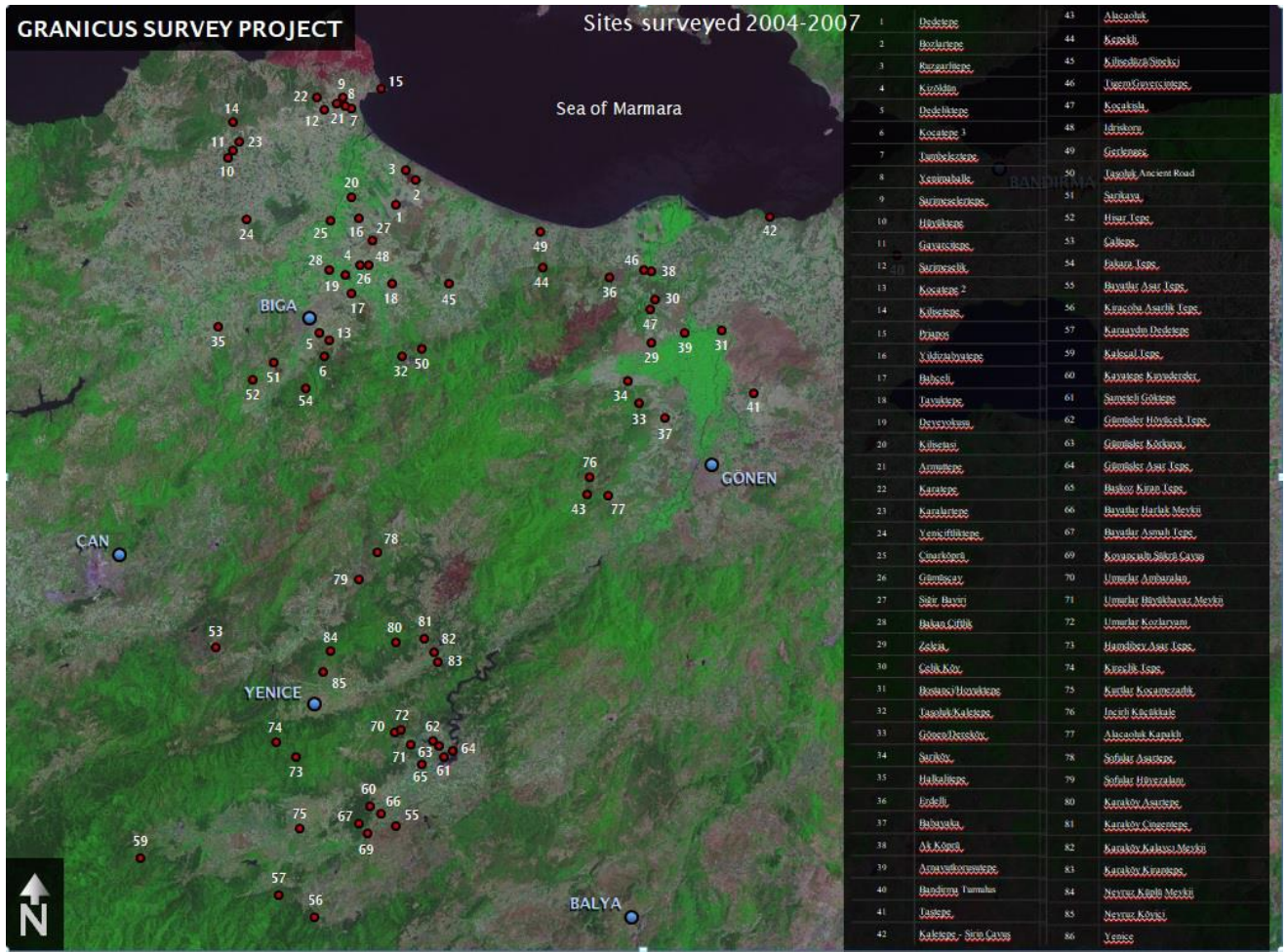

Fig. 1: Granicus Survey Archive 2007 (By Gabe Pizzarno).

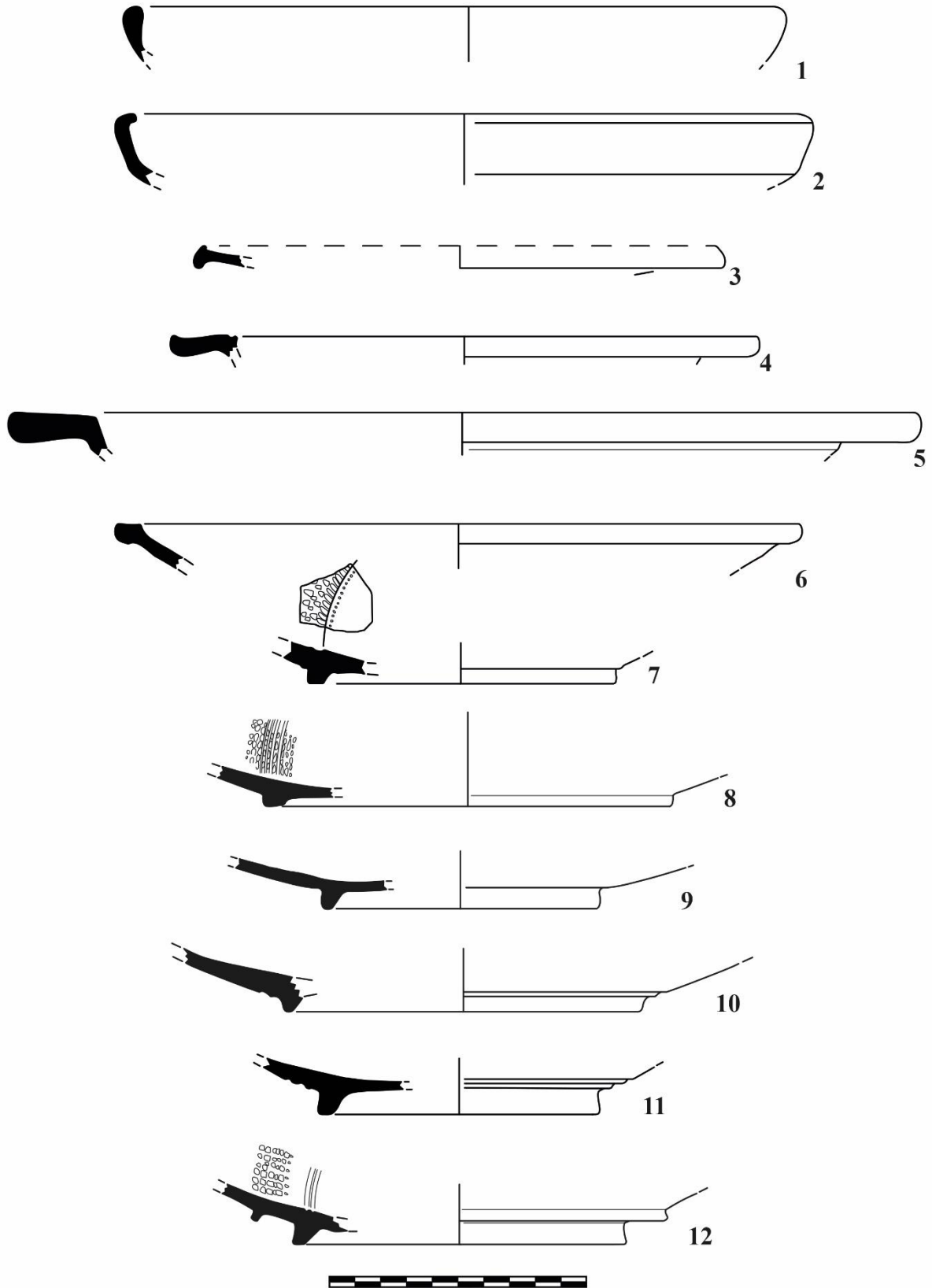

Fig. 2

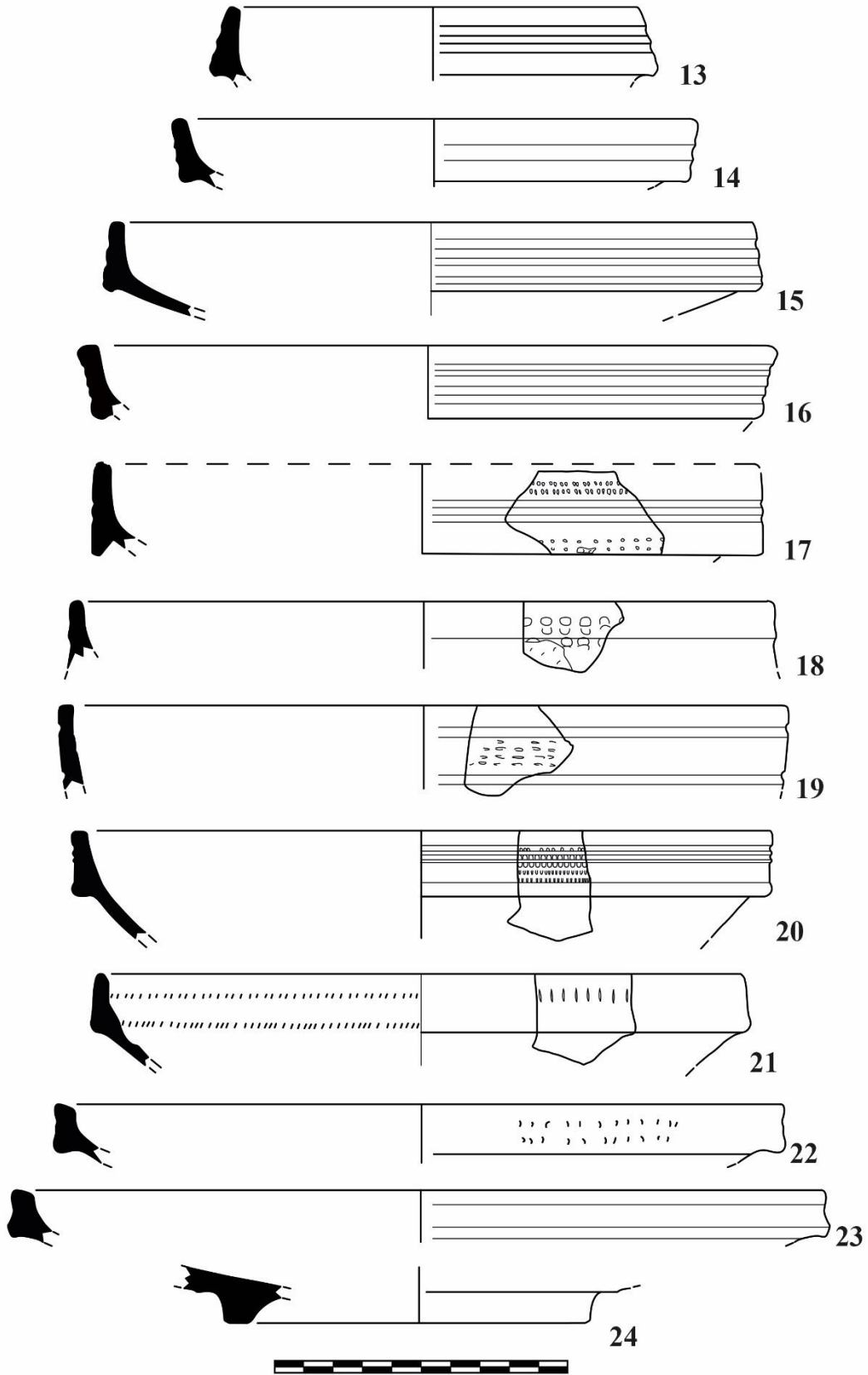

Fig. 3

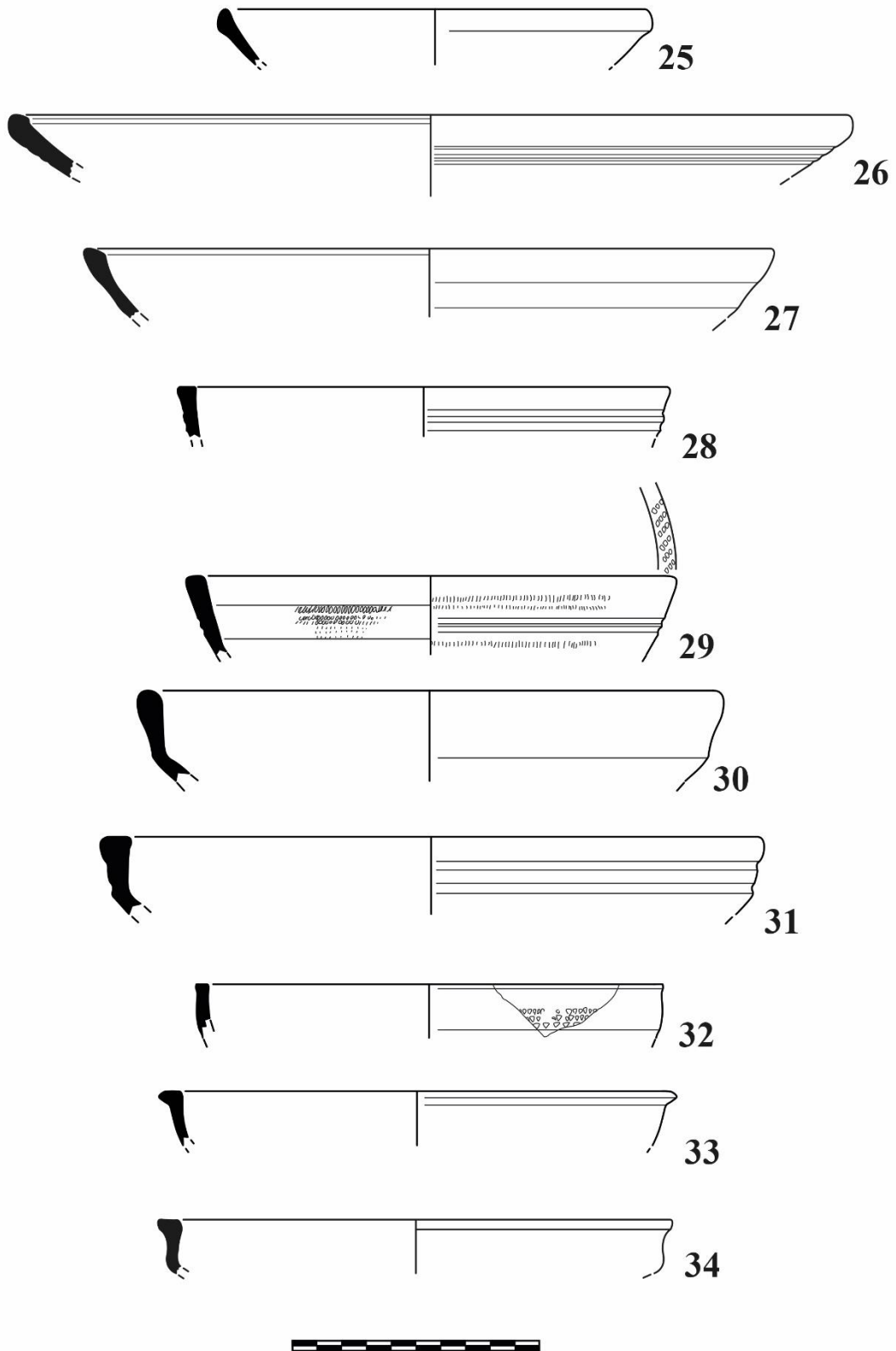

Fig. 4

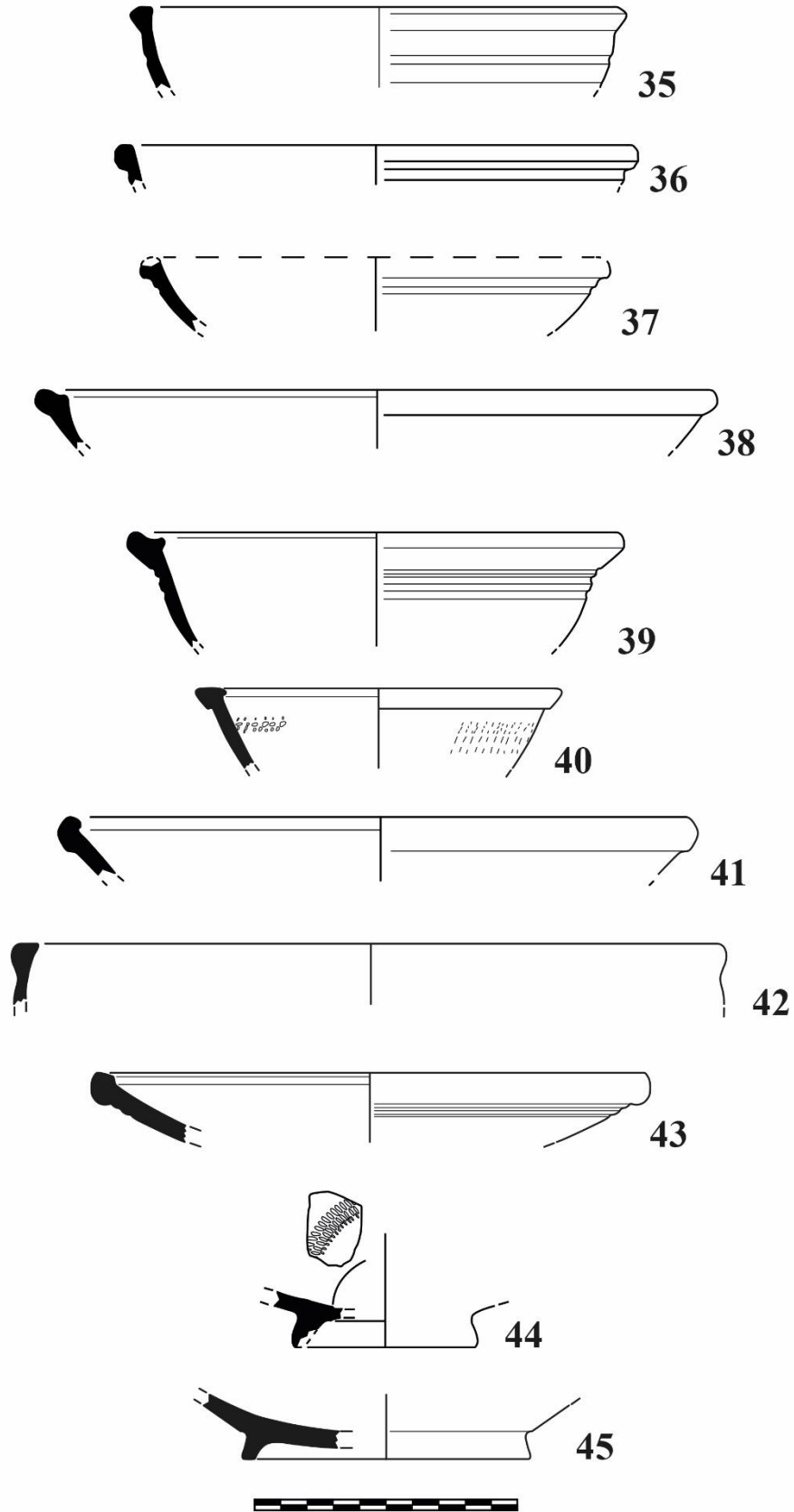

Fig. 5

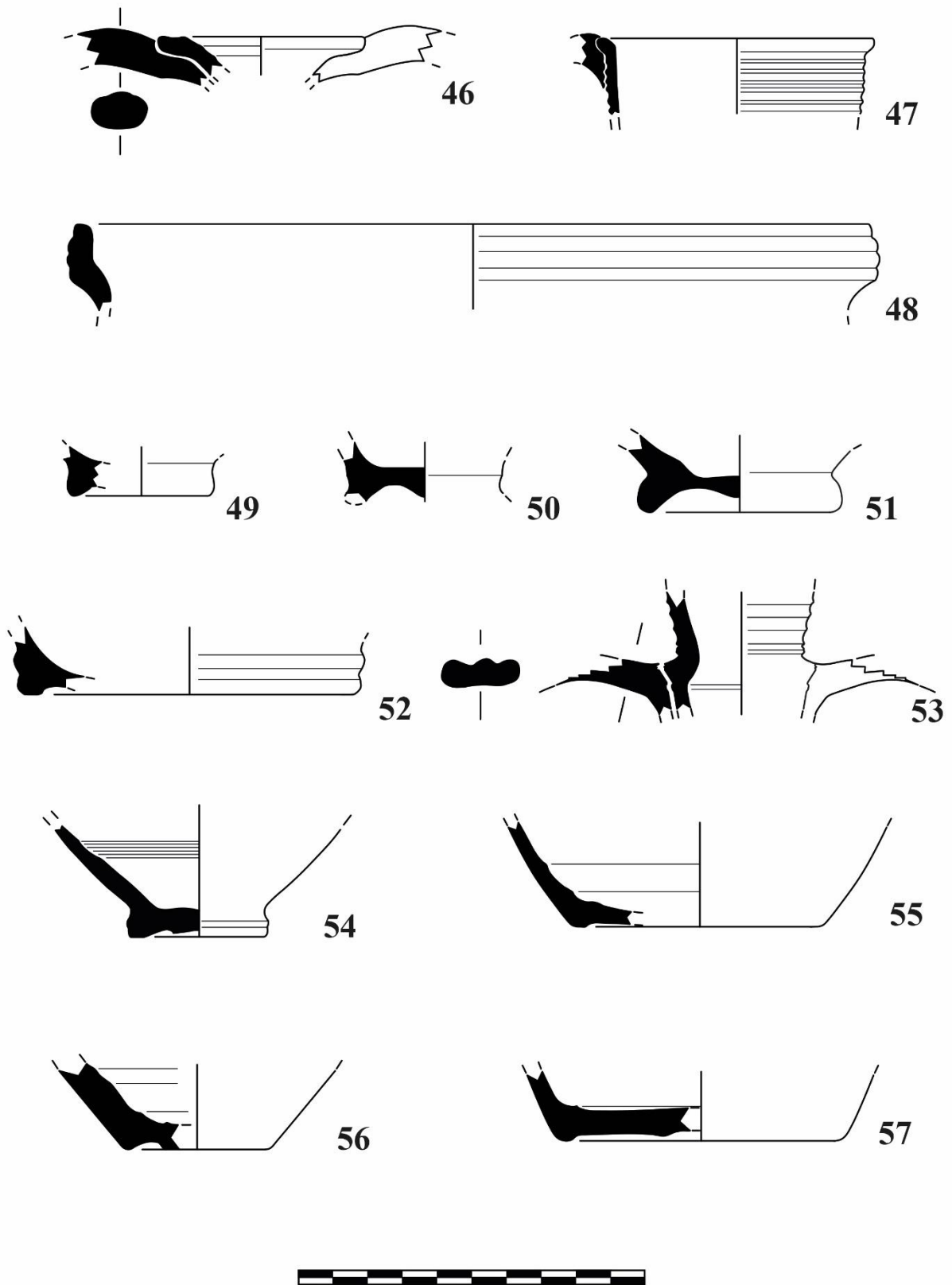

Fig. 6

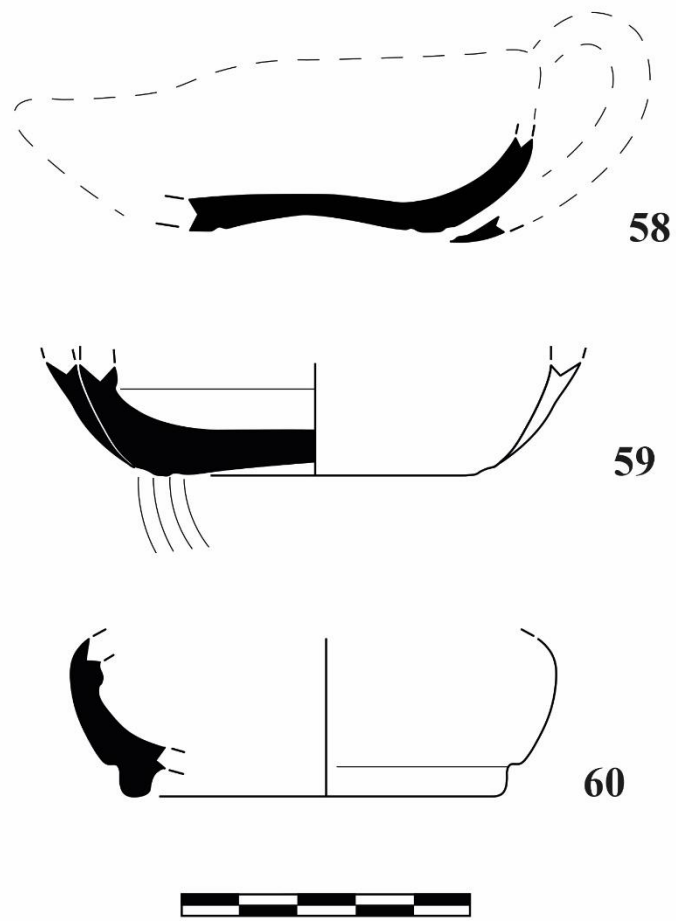

Fig. 7

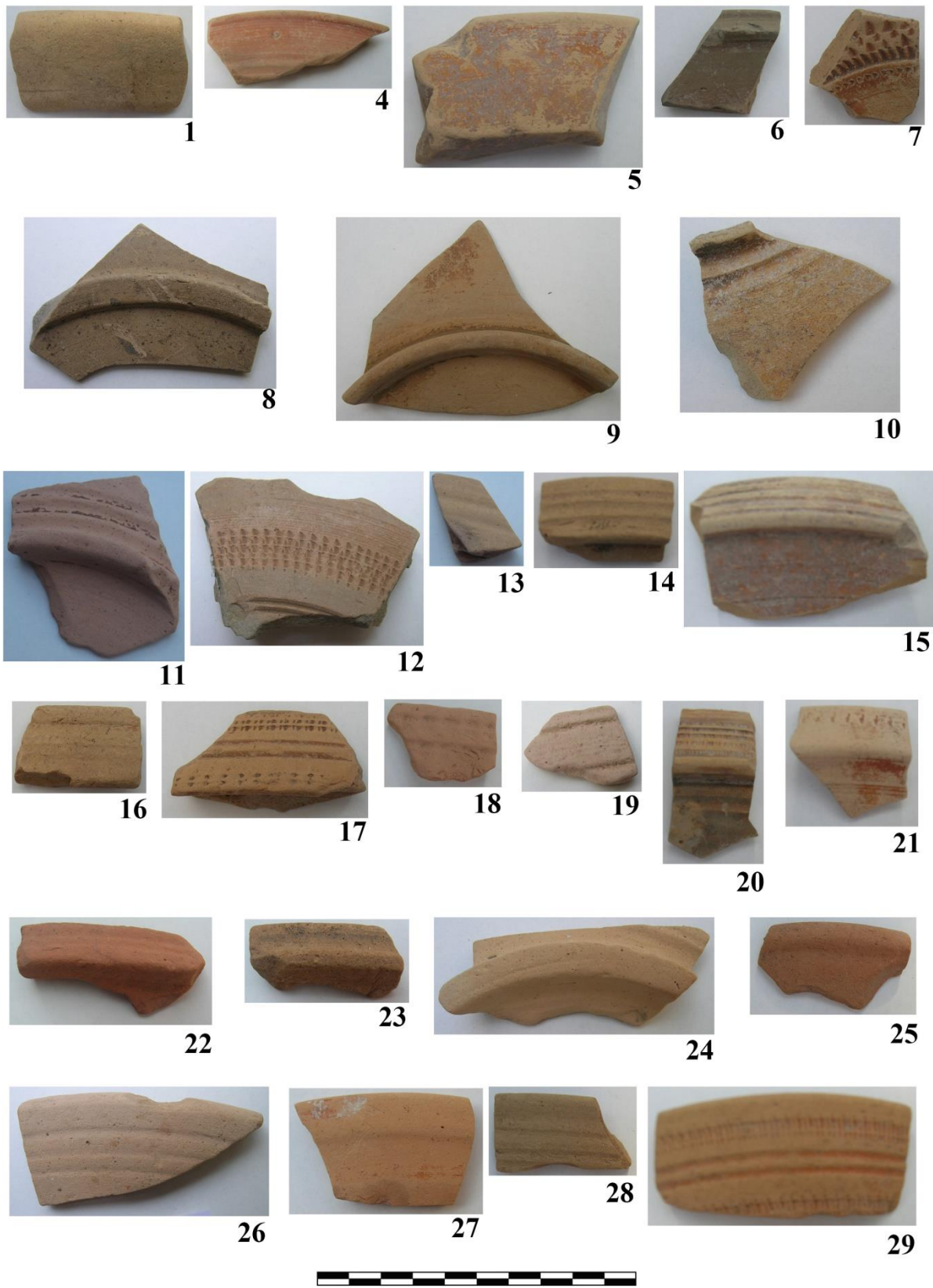

Fig. 8

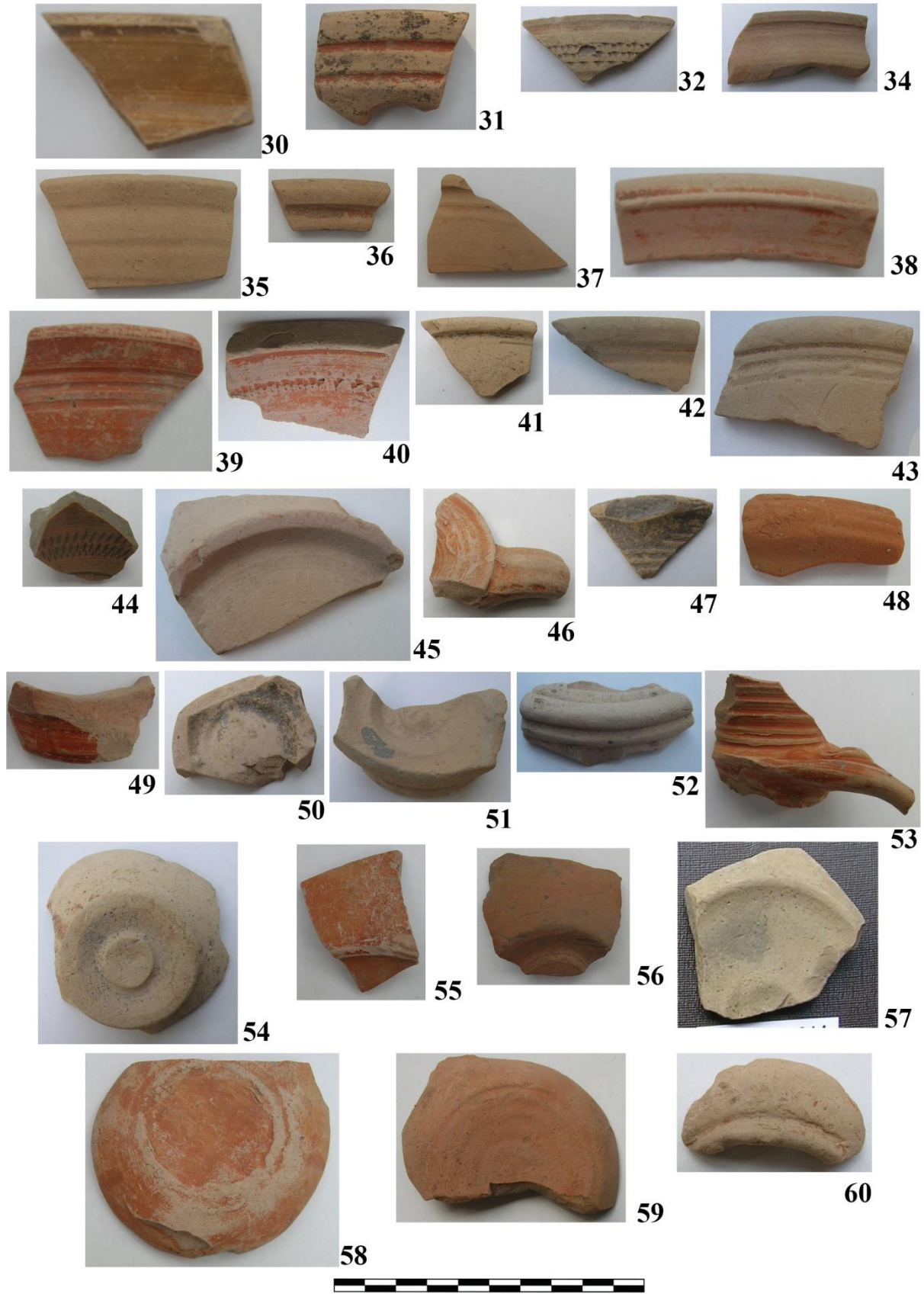

Fig. 9