

MANUFACTURE OF LEATHER SKIRT FROM GARMENT LEATHERS TANNED WITH VARIOUS TANNING MATERIALS AND EVALUATION OF VISUAL PROPERTIES

FARKLI TABAKLAMA MADDELERİ İLE TABAKLANMIŞ GİYSİLİK DERİLERDEN ETEK ÜRETİMİ VE GÖRSEL ÖZELLİKLERİNİN DEĞERLENDİRİLMESİ*

Nilay ÖRK¹, Hasan ÖZGÜNAY¹, Mehmet Mete MUTLU¹, Ziynet ÖNDOĞAN²

¹Ege University Leather Engineering Department, İzmir

²Ege University Textile Engineering Department, İzmir

Received: 10.08.2015

Accepted: 28.03. 2016

ABSTRACT

In this study, effect of material on usage and visual properties on an apparel product produced from leathers tanned with different types of tanning materials, was evaluated. For this purpose, skirts were manufactured from chromium, semi-vegetable and vegetable tanned leathers obtained from two tanneries. Skirt patterns were prepared by using Computer Aided Design (CAD) and Computer Aided Manufacturing (CAM) systems. Leather skirts were evaluated by specialists by using subjective rating scale and the obtained data were analyzed by fuzzy logic method. As conclusion of this study; when visual effects of these skirts were evaluated, it was observed that skirts produced from chromium tanned leathers had better results than the skirts produced from the leathers tanned with other types of tanning materials.

Keywords: Leather, Apparel, Skirt, Tanning materials, Subjective garment evaluation

ÖZET

Bu çalışmada farklı tabaklama maddeleri ile tabaklanmış derilerden üretilen bir konfeksiyon ürünüde materyalin kullanım ve görsel özellikleri üzerine etkisi değerlendirilmiştir. Bu amaçla iki farklı firmadan temin edilen krom, semi-bitkisel ve bitkisel tabaklanmış derilerden etekler üretilmiştir. Etek kalıpları Bilgisayar Destekli Tasarım (CAD) ve Bilgisayar Destekli Üretim (CAM) programında hazırlanmıştır. Deri etekler, oluşturulan jüri tarafından subjektif değerlendirme skalaları kullanılarak değerlendirilmiş ve elde edilen veriler bulanık mantık yöntemi ile analiz edilmiştir. Çalışmanın sonucunda; etekler görsel özellikleri açısından değerlendirildiğinde, krom ile tabaklanmış derilerden üretilen eteklerin diğer tabaklama türlerine göre işlenen derilerden üretilen eteklere göre daha iyi sonuçlar verdiği görülmüştür.

Anahtar Kelimeler: Deri, Konfeksiyon, Etek, Tabaklama maddeleri, Subjektif Yöntemle Giysi Değerlendirmesi

Corresponding Author: Hasan OZGUNAY, hasan.ozgunay@ege.edu.tr

* This study has been produced from the master's thesis completed by Nilay Örk in consultation with Assoc. Prof. Dr. Hasan Özgünay.
Ege University Scientific Research Project Department Directorate (Project No: 11 MUH 010).

1. INTRODUCTION

Selecting the right fabric is something that has to be done to produce well-fitting clothes, allowing the wearer to move comfortably, as well as producing specific design aura and appearance. Since the textile industry is capable of

producing a variety of fabrics with specific features, finding the most suitable fabric for a specific clothing end-use is becoming more important (1). Leather garment industry differs from woven or fabrics industry at various points. Differentiation seems in raw materials features such as size, thickness, biological, chemical or physical homogeneity (2).

The variety of raw material in the leather industry is not as vast as in textile industry however together with the help of developing technology and innovations in manufacturing, many more new leathers with different and distinctive features are allowed to be produced.

Although leather processes and the preferred chemicals have big contribution to designation of final leather characteristics, the type of the raw material, type and amount of tanning material used, have the most important effect (3). Leather product manufacturing starts with selection of the convenient raw material according to expected features from leather product. The raw material has a wide spread of variety from thin and loose structured sheep skins to thick and dense structured hides or even to the exotic skins. The properties of a leather consumer good are mainly originated from the raw material. However together with recent developments in leather chemicals and production technologies the most features of leather products, without depending on features of raw skin/hide, can be changed during the manufacturing processes. In this condition, tanning process is considered to be more important. Mineral, vegetable and synthetics based tanning materials being used in leather industry gives opportunity of producing many different products with different characteristics from the same type of raw material via contribution of various application techniques and the following processes that are used in leather production.

While traditionally sheep skins were being used for production of flexible, soft and light garment leathers, in recent years they are started to be used for production of shoe upper leathers and linings with higher form retention ability, strength and less flexibility by modification of tanning materials and the following processes.

Likewise some tanning agents also allow manufacturing of leathers with very different properties. For example, although vegetable tanning materials are generally used in production of saddlery, harness, belt, shoe upper and sole leathers requiring less elasticity, high shape retention and firmness; their use in garment leather production has increased due to natural look and feel they confer to leathers and high demands on natural products in last decades (4).

Depending on the fields of use, specific performance characteristics are expected from the leathers. For instance; leather clothing is affected both by its basic mechanical properties and usage characteristics and by the manufacturing features of the leather. The important basic mechanical properties of leather clothing include even thickness, breaking tension, breaking force and area stretching, whereas the usage specifics refer to permeability to air and water vapour, washing and dry-cleaning characteristics, colour stability, resistance to repeated folding (flexing), finish adhesion, and heat and cold resistance (5). In addition to the basic mechanical and usage characteristics, the mechanical properties of leather clothing indicates that the behaviour of leather under low stress is also vital for the garment manufacturing process and fitting quality (6). Garment quality is not defined only through its mechanical and functional properties, but also through the aesthetic appearance and quality of the

material, its proper drape and fit - visual quality of form (7, 8). 3D behaviour of the leather clothing is very important. It is one of the basic criteria for evaluating the shapes of garments produced. It can be evaluated on the basis of formability and drape. Formability is a specific leather clothing property, defined as the ability of leather clothing to be transformed from two-dimensional into a simple or complex three-dimensional form (5).

Physical and fastness properties of garment leathers tanned with various tanning materials for leather skirt production were investigated in our previous study (3). As a complementary research; in the present study it is aimed to determine the suitability of the leathers, which are being produced in leather industry by using chromium, semi-vegetable and vegetable tanning agents, for apparel production. For this purpose skirt is chosen as a material from apparel products. Besides within this research, the process flow in leather apparel production and the details to be considered are experienced and explained. The skirts were evaluated by using fuzzy logic method considering the visual and usability aspects in terms of their suitability for leather garments.

2. MATERIAL AND METHOD

2.1. Materials

Persian and English origin sheep leathers, which were tanned with Chromium (C), Semi-Vegetable (Chromium and Vegetable Combination) (S), Vegetable (V) and processed accordingly for garment leather obtained from two companies, were used in the production of leather skirts.

The equipment, tools and accessories used during the leather skirt production are indicated below:

- Assyst CAD System
- ZUND M800 Digital cutter
- Pfaff 1245 Single-needle, lockstitch flatbed sewing machine with large vertical hook (Unison feed)
- Polyester lining
- Polyester Close-End zipper
- Oltali spun polyester sewing thread 300 dtex X 2, No.50 (3 stitch/cm)
- Adhesive for leather apparel (Kırmızıgül Adhesives S-57)
- Strong adhesive (Derby)
- Knuckleduster
- Double sided seam tape

2.2. Method

As leather is a natural material with non-homogenous feature, partial differences can occur even on itself. For instance, it is found that the strength is not even over any very large area; highest close to the backbone line of leathers, decreases gradually while moving away from the line of backbone to the edges and the areas around kidneys are weaker than the areas around neck (9). That's the reason that patterns which have a large surface area cannot be used in leather apparel manufacturing. Therefore to eliminate structural and surface differences and provide a

homogenous look and physical properties, leather skirt was designed as four-pieces (with bodice) on front and back. Measurements of live mannequin and model design are given in model analysis (Figure 1).

Many different pattern making systems are used in the apparel industry, developed according to the nation's

anatomy and changes in the pattern preparation steps with respect to different systems (10). In this study, the skirt patterns were designed by using Assyst CAD system in conformity with German pattern drafting system M. Müller & Sohn (Figure 2). The carton drawing and cutting of patterns were made by using ZÜND M800 Digital Cutter.

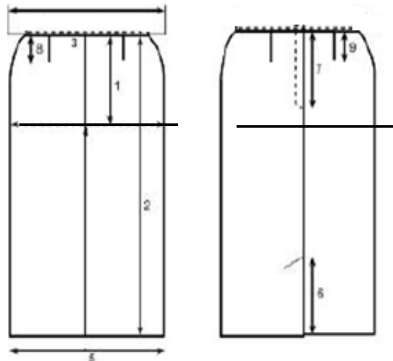
MODEL ANALYSIS				
SIZE: 38				
PRODUCT: Straight Tight Skirt (Lined)				
1	Hip Low	18	PIECES LIST	
2	Hemline	52	Leather	Lining
3	Waist Width (1/2)	36	Front: 2	Front: 1
4	Waist to Hip	18	Back: 2	Back: 2
5	Hip Width (1/2)	51		
6	Skirt Length Width (1/2)	51		
7	Zipper Length	18		
8	Front Dart	9		
9	Back Dart	12		
GRAPHIC ARTWORK			MODEL ANALYSIS	
			<ul style="list-style-type: none"> • Front two pieces (with bodice) • Back mid 18 cm zipper • Slit length 12 cm • Trimming 3 cm 	
			<p>MATERIALS</p> <ul style="list-style-type: none"> • 18 cm zipper • Garment sheep leather • Polyester lining • No.50 polyester thread 	

Figure 1. Model Analysis of Leather Skirt

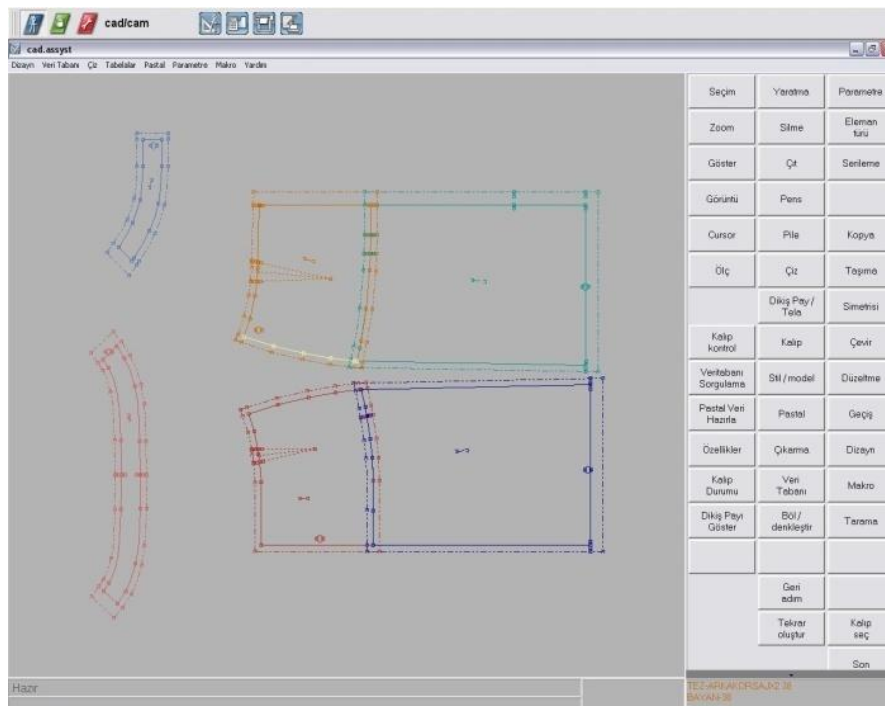


Figure 2. Screenshot of Skirt Patterns on Assyst CAD System

The leathers which will be used on skirt manufacture were assorted to constitute small homogeneous groups under standard light conditions considering their colours, handle, touch and surface appearance properties as the first step of the leather apparel manufacture. The selected leathers have been laid on an inclined cutting table individually and they were cut with special knives by placing skirt patterns on them. Sign notches placed on the pattern (zip, slit length, dart width) were indicated by small clips and dart length is indicated by silver paint marker. At this stage it was calculated that one skirt was going to be obtained from 300dm² of leather in average.

The leather pieces of each skirt were numbered on flesh side of leathers with crayons to avoid confusion and sewn by using Pfaff 1245 sewing machine. Then, the interfacing was fused on belt trimming to prevent flexing and provide fullness at the waist. Darts marked with silver pen were sewn, cut from inside and seam allowances were folded and pasted. In leather apparel manufacturing, sewing priority is generally horizontal seams. I.e. the upper and lower parts are sewed firstly. Accordingly, the lower pieces were sewn with bodices. The interfacing was fused on belt and hem to prevent flexing again. Then the zipper was sewn. Side seams were sewn and front and back of the skirt were combined by sewing. Adhesive applied seam allowances were folded and the seams were set out by knuckleduster, which is a hammer like special tool used for setting out the folded seam allowances. Skirt's waist was sewn to belt trimming and folded. Topstitches and edgestitches were applied on the hip and waist sewing lines.

In the lining sewing, at first darts then side seams were done. Lining and leather were sewn in tube form on belt trimming at the waist.

After sewing, skirts were taken to the handiwork section. At this section marks of silver paint marker were cleaned with vaseline by brush rubbing. Exuberated strong adhesive on leather garments has been removed by the rubber. Thread remains were cut and removed. Short threads, which scissors can't cut, were burned with the help of a lighter. This was followed by ironing. The ironing process was made by placing a fabric on the skirt to avoid any possible heat damage to the leather. In leather apparel generally garment leathers are ironed at 80-100°C, nubuck and suede leathers are ironed at 100-120°C. Electro-pneumatic ironing press machines are used to give form to the product and to smooth the surface. Top and bottom plates of ironing press are coated with heat resistant fabric. In this study, the leather skirts were ironed at 100°C with an ironing press.

The next step was last quality control stage. At this stage, any defects in products, seams skewness or errors and measurements have been checked. After approval, the skirts were taken to the final ironing and packing.

After finishing the leather skirts' manufacture, fuzzy logic method was used in order to evaluate clothing properties and quality of skirts subjectively.

People express their ideas with the best way to verbal terms. Therefore, a method was needed to cover the assessment expressed in verbal terms. Fuzzy logic method has been proposed for these reasons. It emerges as an important method because of solving the encountered problems in the real world and includes the uncertainty in this problem (11).

As evaluation parameters:

- Body posture of skirt (standing)
- Body posture of skirt (sitting)
- Seam outlook of skirt,
- Suitability of leather to the pattern,
- Drape of skirt,
- Sitting view of skirt (if there exists any pot)
- The quality of leather used in the production of skirts,
- Softness of the leather used in the production of skirts,
- Wrinkling feature of the skirt (after sitting - standing up)
- Dart seam uniformity of skirt,
- General evaluation of the skirt,
- The visual impact of the skirt, criterion were selected.

Evaluation rating was scaled as: very good (0.9 points), good (0.7 points), medium (0.5 points), bad (0.3 points) and very bad (0.1 points) in accordance with fuzzy logic method in which evaluation scale should be between 0-1. Eight people who are experts in the field of leather and apparel were set up as a jury. The members of the jury evaluated the skirts independently according to the parameters given above. The scores of the jury for each skirt were summed and the final score of the skirt was given as mean value.

Moreover, in order to support subjective evaluation results, the percentage of drapeability and angle of wrinkling features of the leathers were determined according to TS 9693 and TS 390 EN 22313 respectively (12,13).

3. RESULTS AND DISCUSSION

Front and back appearances of leather skirts are illustrated in Figure 3-5.

From the investigation of the data in Table 1 and Figure 6; it is clearly seen that chromium tanned leather skirts have taken the highest score according to the defined criteria. Considering the angle of recovery from creasing and drapeability test results of the leathers which are given in Table 2, it clearly seems that chromium tanned leathers given compatible results in accordance with the subjective evaluation results except drapeability result of chromium tanned leather from Comp.II. However this phenomenon is discussed at the end of this section.



Figure 3. Views of Chromium tanned leather skirts



Figure 4. Views of Semi-Vegetable tanned leather skirts



Figure 5. Views of Vegetable tanned leather skirts

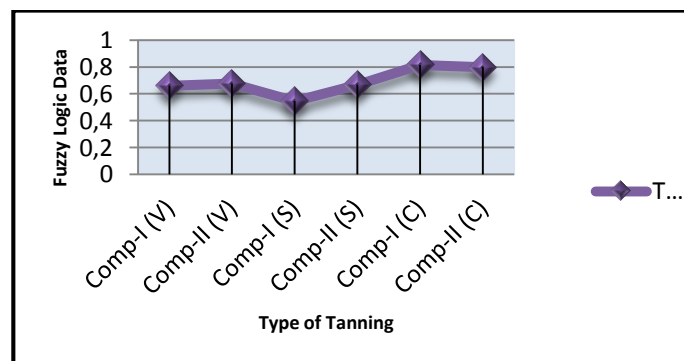


Figure 6. The results obtained by fuzzy logic method

The evaluation results of the jury are given in Table 1.

Table 1. Evaluation results of the leather skirts manufactured from different leathers

Criteria	Comp.-I (V)	Comp.-II (V)	Comp.-I (S)	Comp.-II (S)	Comp.-I (C)	Comp.-II (C)
Body posture of skirt (standing)	0.7	0.6	0.6	0.7	0.7	0.8
Body posture of skirt (sitting)	0.6	0.7	0.6	0.6	0.8	0.8
Seam outlook of skirt	0.8	0.7	0.6	0.7	0.8	0.8
Suitability of leather to the pattern	0.7	0.6	0.6	0.6	0.8	0.8
Drape of skirt	0.6	0.6	0.5	0.6	0.8	0.7
Sitting view of skirt (if there exists any pot)	0.7	0.7	0.6	0.7	0.7	0.8
The quality of leather used in the production of skirts	0.5	0.6	0.4	0.6	0.7	0.7
Softness of the leather used in the production of skirts	0.6	0.7	0.5	0.6	0.8	0.8
Wrinkling feature of the skirt (after sitting - standing up)	0.5	0.5	0.4	0.6	0.7	0.6
Dart seam uniformity of skirt	0.6	0.7	0.4	0.7	0.8	0.9
General evaluation of the skirt	0.6	0.6	0.5	0.7	0.8	0.8
The visual impact of the skirt	0.5	0.5	0.6	0.7	0.9	0.6
Overall average	0.6	0.6	0.5	0.7	0.8	0.8

Comp.: company

Table 2. The angle of recovery from creasing and drapeability test results of the leathers

	Comp.-I (V)	Comp.-II (V)	Comp.-I (S)	Comp.-II (S)	Comp.-I (C)	Comp.-II (C)
The Angle of Recovery From Creasing (°)	85.17	104.33	118.83	107.50	114.17	130.83
Drapeability (%)	50.93	48.82	39.24	47.02	35.55	49.31

Recently; depending on environmental pressures and interests in natural products and demands for more naturally processed leathers drove researchers to search alternatives to chromium in tanning. In this sense, synthetic and vegetable tanning agents can be considered among the most important alternatives.

However; although leather processes and the preferred chemicals have big contribution to designation of final leather characteristics, the type of the raw material, type and amount of tanning material used, have the most important effect.

As a matter of fact; in the first part of the study in which physical and fastness properties of garment leathers tanned with various tanning materials for leather skirt production were investigated: the statistical evaluation of the physical test results of leathers tanned with different tanning types, showed that tanning type has important effect on the physical properties of leathers even from the same origin. Physical properties of the leathers were varied due to the tanning material used in their production (3).

Considering the results given in Table 1, it is obvious that the variations in the physical properties of leather samples were also reflected when these materials converted to leather products.

Comfort is related with physical properties owned by dresses or fabrics. Wearing comfort can be defined as satisfaction and feeling the balance of a person inside the dress and environmental conditions at that time with physiological, psychological and physical point of view and it is an important factor considering the selection of a dress (14). Various consumers consider comfort as one of the most important attributes in their purchase of apparel products, therefore companies tend to focus on the comfort of apparel products (15).

As can be seen from the values in this study, the leathers treated with vegetable and chromium / vegetable combination tanning agents that are alternative to chromium, could not fully match the visual effect, quality and comfort properties which were given by chromium to leather products alone. However; these properties of semi-vegetable tanned leather products can resemble the characteristics of chromium tanned leathers depending on vegetable / mineral tanning agent ratio, selecting chemicals and their amounts properly in post tanning processes.

This phenomenon was also explained as; generally, semi vegetable tanned leathers are produced by the vegetable agents (10-25% over weight) of primarily chromium tanned leathers (containing 1-2.5% Cr₂O₃). For this reason these types of leathers can show similar properties either to chromium tanned leathers or to vegetable tanned leathers depending on the proportion of chromium and vegetable tanning materials used (3).

4. CONCLUSION

In this study, conformity of garment leathers tanned with chromium, semi-vegetable and vegetable tanning agents for skirt as apparel has been determined in terms of organoleptic (sensory-tactile) and body movements comfort and besides, the leather apparel processes and the details of them were tried to be explained.

The following points can be emphasized regarding leather apparel;

- Leather apparel is a labor intensive production including a series of complex processes and has some differences from textile. In these processes, each one has its own significance and contributes to the quality of final product,

- For example, the assortment step plays an important role on visual and quality properties of finished leather products. It requires experience and attention, and the laborer who works at this stage has to recognize the leather properties very well,
- Generally sheep garment leathers do not have a large surface area, therefore when the leather garments (from sheep garment leathers) are designed; their models have to be constituted from multi-pieces. This situation creates some difficulties for designers and pattern makers, and requires knowledge about leather apparel and its features,
- In sewing step, seam allowances should be folded and set out with a knuckleduster after applying adhesive on their flesh sides. If this implementation is not done properly, the visual appearance of finished garment would look bad because of the wrinkled appearance on seam lines,
- After sewing, the handiwork section is important for clean and qualified finished leather product. Exuberated strong adhesive, marks of silver paint marker and thread remains have to be removed from the product. Another important issue is selecting the right temperature in ironing for the type of leather used.

Additionally, from the subjective evaluation (by using fuzzy logic method) of six leather skirts (manufactured from the leathers which were obtained from two companies and tanned with various tanning agents) the following conclusions are obtained:

- Considering the average scores; chromium-tanned leather skirts got the highest scores for both companies,

in spite of the fact that they were produced in different companies by different process and chemical choice,

- In terms of drape of skirt, sitting view of skirt (if there exists any pot), softness of the leather used in the production of skirts, dart seam uniformity of skirt, general evaluation of the skirt, the visual impact of the skirt; the chromium tanned leather skirts got prominently the highest values,

Chromium tanning has for a long time enjoyed a unique position amongst tanners all over the world and almost 90% of all leather produced is chromium tanned. The main reason for this relates to the following characteristics of chromium tanned leather: high shrinkage temperature/hydrothermal stability, good flexibility, excellent fastness properties, lightweight and not too full, good comfort characteristics, good moulding and shape retention properties (16).

- However, from the evaluation of the results; it was also seen that semi-vegetable tanned leather products followed chromium tanned leather skirts which means they can resemble the characteristics of chromium tanned leathers depending on vegetable / mineral tanning agent ratio, properly selecting chemicals and their amounts in post tanning processes.

From the general evaluation; it was seen that although contribution of leather processes and chemicals used in production are very effective in determination of the final features of a leather and leather product; the type of hide/skin and the tanning materials and their amounts have predominant effect.

REFERENCES

1. Gider, A., 2004, An Online Fabric Database to Link Fabric Drape and End-Use Properties, Louisiana State University and Agricultural and Mechanical College, MSc. Thesis, *Istanbul Technical University*, pp. 1.
2. Utkun, E. and Öndoğan, Z., 2011, Comparison of Jacket Production Processes Designed by Fabric Materials and Leather, *Pamukkale Üniversitesi Mühendislik Bilimleri Dergisi*, Vol. 17, pp. 79-85.
3. Örk, N., Özgünay, H., Mutlu, M. M. and Öndoğan Z., 2014, Comparative Determination of Physical and Fastness Properties of Garment Leathers Tanned With Various Tanning Materials for Leather Skirt Production, *Tekstil ve Konfeksiyon*, Vol. 24, pp. 414-418.
4. Jones, C., 2000, The manufacture of vegetable tanned light leathers Part 1, *World Leather*, pp. 80-83.
5. Urbanija, V. and Gersak, J., 2004, Impact of The Mechanical Properties Of Nappa Clothing Leather On The Characteristics of Its Use, *Journal of The Society of Leather Technologists and Chemists*, Vol. 88, pp. 181-190.
6. Urbanija, V., 2002, Study of the Influence of Mechanical Properties of Garment Nappa Leather on its Applicable Properties, MSc. Thesis, *University of Maribor, Faculty of Mechanical Engineering*.
7. Gersak, J., 2003, Investigation of the Impact of Fabric Mechanical Properties on Garment Appearance, *Tekstil*, Vol. 58, pp. 368.
8. Gersak, J., 2000, Study of The Relationship Between Fabric Mechanics and Garment Appearance Quality Level, *Proceedings 1st International Textile, Clothing & Design Conference*, pp. 353.
9. Mutlu, M. M., Örk, N., Yeğin, O. and Baş, S., 2014, Mapping The Variations of Tensile Strength Over The Area of Sheepskin Leather, *Annals of The University of Oradea*, Vol. 15, pp. 157-162.
10. Tama, D. and Öndoğan, Z., 2014, Fitting Evaluation of Pattern Making Systems According to Female Body Shapes, *Fibres & Textiles in Eastern Europe*, Vol. 22, pp. 107-111.
11. Ofiuoğlu, P. and Miran, B., 2014, Supplier Selection Through Fuzzy Pair-Wise Comparison Method: A Case Study for Turkish Clothing Companies, *Journal of Textiles and Engineer*, Vol. 21, pp. 1-9.
12. TSE, TS 390 EN 22313, 1996, Textile Fabrics-Determination of The Recovery From Creasing Of A Horizontally Folded Specimen By Measuring The Angle Of Recovery.
13. TSE, TS 9693, 1991, Textiles the Assessment of Drape of Fabrics.
14. Bahadır Ünal, Z., Acar, E. and Yıldırım, F., 2015, Evaluating Performance Characteristics of Lining, *Tekstil ve Konfeksiyon*, Vol. 25, pp. 323-328.
15. Cüreklibatır Encan, B., Temel, C., Tama, D., Öndoğan Z and Yurdakul, B., 2013, Evaluation of Certain Fabrics' Thermal Comfort Properties and a Design Suggestion for Active Sports, *The International Istanbul Textile Congress*.
16. Dasgupta, S., 2003, Modified Thrublu Chrome Tanning for Lambskins: Low Residual - Chrome Tannages, *Journal of the Society of Leather Technologists and Chemists*, Vol. 88, pp. 116.

