

Development of A Measurement System for Weighing of Tuber Crops on A Conveyor Band

Bülent ALBAYRAK Bahattin AKDEMİR*

¹Namık Kemal Üniversitesi Biyosistem Mühendisliği Bölümü, 59030, Tekirdağ, Türkiye

*Sorumlu yazar: Email: bakdemir@nku.edu.tr

Geliş Tarihi (Received): 15.11.2016

Kabul Tarihi (Accepted): 19.04.2017

In this study, a specific design and manufacturing of a weight measurement system for tuber crops on a belt scale were conducted. The chassis of the belt scale was constructed by equal legs steel profile. The belt material was PVC. The rotational motion of the belt scale was obtained by an AC electric motor. The speed of the belt was measured by a tachometer. Several rollers were used to support the vertical loads on the belt. One of the rollers was connected directly to load cell to measure the weight of the tuber crops. In order to obtain the mass flow on the belt, the data of weight per unit meter from load cell and the speed data from tachometer were transmitted to an electronic board. Multiplication of these two data gives the unit mass flow rate of the tuber crops on the belt scale. The unit mass flow rate and total mass flow rate was displayed on an LCD display. The accuracy of this system was found to be between 96.4% - 97.5% during measurement of weight on a moving belt scale.

Key Words: Belt scale, load cell, tuber crops, weight measurement, precision agriculture

Bant Konveyör Üzerinde Yumru Bitkilerin Ağırlıklarının Ölçülmesi İçin Ölçme Sisteminin Geliştirilmesi

Bu araştırmada, yumru bitkilerinin hareketli bir bant kantarı üzerinde ilerlerken ağırlıklarını anlık ve toplam olarak ölçen bir sistemin tasarımı ve üretimi yapılmıştır. Bant kantarının şasisi köşebent profilden imal edilmiştir. Sistemde PVC bant kullanılmış ve bantın dönüş hareketi bir elektrik motoru ile sağlanmıştır. Bant hızı bir takometre ile anlık olarak ölçülmüştür. Düşey yükleri taşımak için bant altında rulolar kullanılmıştır. Bu rulolardan biri ağırlık ölçmek için yük hücresine bağlanmıştır. Yük hücresinden gelen birim metredeki ağırlık bilgisi ile takometreden gelen hız bilgisi kullanılarak bir elektronik devre yardımı ile birim zamanda geçen yük miktarı hesaplanmıştır. Bu bilgiler LCD ekranda anlık olarak gösterilmiştir. Yapılan denemeler sonucunda %96.4 - %97.5 arasında doğruluk payıyla ağırlık hesabı yapılmıştır.

Anahtar Kelimeler: Bant kantarı, yük hücresi, ağırlık ölçümü, yumru bitkileri, hassas tarım

Introduction

Determination of yield variability and creating of yield map related to positioning system in the fields or in orchards is important in precision farming applications to see the implementation strategy of agricultural input in current year and, it also helps to predict the agricultural input quantity for the next year.

Tuber crops such as potato and onion are commonly harvested manually and sacked in Turkey. Aim of this research is to design and manufacture of a belt conveyor to weigh tuber crops during harvesting and transportation processes. Developing such system will make possible to be a part yield mapping system and therefore create yield maps for this kind of manually harvested crops. Belt conveyors are frequently used in agricultural applications as

transportation equipment. In this study, a belt conveyor was designed and produced in order to weight the crops simultaneously and to get the total flow rate considering the concept of adding weight measurement system to ordinary belt conveyor systems. Belt conveyors have been produced by several commercial companies and used commonly nearly in the most of the industry sectors. However they are used mainly in transportation and weighing of regularly and steady feeding goods. Surveys on weighing the crops which have different weight, shape and represent non-uniform load distribution on a moving belt are very limited.

Sulak (1993) designed and produced a belt conveyor that works with farm tractor. Belt conveyor can be moved on the ground and connected to three point hitch system. It is driven by PTO. Fisher et al. (1997) worked on precision

farming for sugar beet. It is aimed to construct yield maps and using these maps for fertilization by precision farming applications. Hall et al. (1998) has worked on a yield monitoring system that works on a harvester. Results are evaluated by comparing standard deviations and vehicle – load deviations. All figures from each system are also compared with yield maps. Ehlert (2000) has worked on measuring potato flow rate to get yield maps. In the study, it is concluded that there is a direct correlation between load and flow rate when setting up a constant velocity difference during transfer of potatoes. Algerbo and Ehlert (2000) worked on yield measurement system on a potato harvester. Two different systems are tested to measure the yield flow rate. One of the system is based on a mechanical system setup on a weight plate. The other one is based on an optical system that uses an optical camera. The design, implementation, monitoring and evaluation system at a workshop a potato yield monitoring studied by Zamani et al. (2014). This study developed a method which is accurate for potato yield mapping.

In 1997 and 1998 the commercially available conveyor weighing system called Harvestmaster HM500 was evaluated on a trailed, single-row,

offset-lifting, bunker-hopper potato harvester on the experimental farm Scheme. The system worked well and the reached accuracy, with a standard deviation of the relative errors of 4.1%, was similar to that of yield measurement systems used in combines. Local yield data were corrected by the content of contaminants and yield maps were calculated. Regression analysis of the average relative grid yields of four years showed different yield patterns in comparison to combinable crops on the same two fields (Demmel and Auernhammer, 1999).

Material and Methods

Potatoes and onions

In this research; potatoes and dry onions were used for measuring weight by belt conveyor. The dimension and weight of the potatoes varied between 6.5 cm and 10 cm and 150 g and 200 g. The dimension and weight of the onions varied between 4.5 cm and 7.4 cm and 50 g and 75 g.

Belt Scale

Three dimensional computer model drawing and a picture of the belt scale and its basic parts except for control unit and tachometer are shown below (Figure 1).

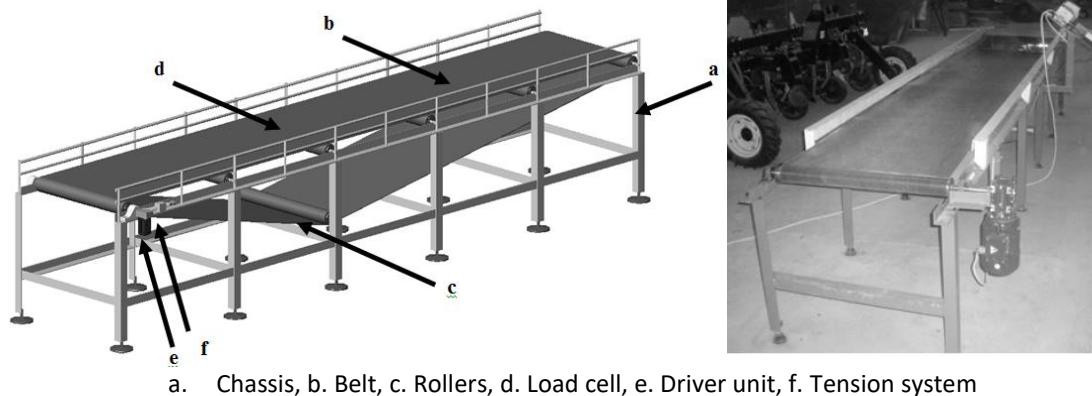

Figure 1. Computer modelling and photo of belt scale

The chassis of the belt conveyor was produced with steel profile whose dimensions were 50x50x5mm. Nuts are mounted on the legs for balance and adjustable bolted legs are joined to the nuts to make the balance easier. A smoothed surface, 2.5 mm thickness, 77 shore. A hardness yellow PVC belt is used. There are three types of rollers used in the belt scale: support rollers, tension roller and load cell roller. All rollers are produced from 50.8 mm (2") steel tube profile. In both sides of the rollers, roller bearings are used

and the bearings are mounted with 20 mm steel profile. Several 10.5 mm x10.5 mm slots are placed on the chassis in order to place the rollers on the chassis. The slots are also allow the roller to rotate around themselves. Totally 9 rollers are used. One of them is used for load cell, another one is used for tension of the band and the rest is used for supporting the belt.

Load cell

Technical properties of the load cell are given in Table 1.

Table 1. Technical properties of load cell

| Technical properties | Unit | Data |
|--|------|-----------------|
| Maximum capacity | kg | 200 |
| Accuracy class (According to OIML R 60 std.) | | C1 |
| Maximum discretization number (n_{lc}) | | 1000 |
| Minimum measurement interval (v_{min}) | | $E_{max}/5000$ |
| Total error | % | $\leq \pm 0.05$ |
| Efficiency (Cn) | mV/V | $2 \pm 0.1\%$ |

Tachometer

A tachometer is used to get belt speed (Figure 2). Belt speed was calculated by dividing of circular distance of fixed diameter of the tachometer to

time elapsed during the motion of the belt. A complete 360° revolution of the circular wheel of the tachometer gives several signals during rotational motion.

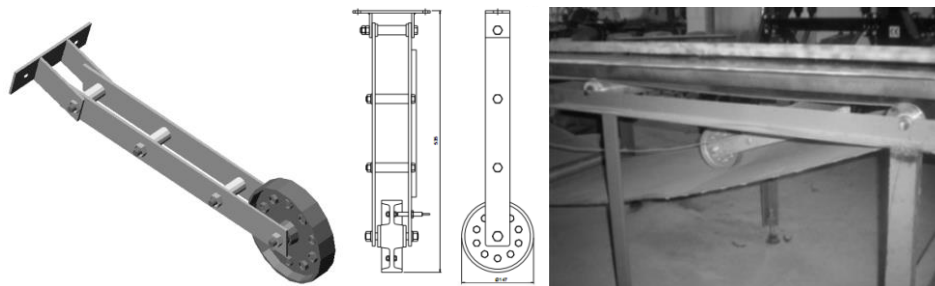

Figure 2. 3D computer modelling and picture of application of tachometer

Tension system

A mechanical system was constructed for belt tension system. Tension system was set up on driver roller. Bearing of driver roller was fixed on flat steel by two bolts (Figure 3). Tension was

adjusted by a special long bolt and a nut. This special bolt was welded on chassis therefore the precision of tension was obtained parallel to pitch of bolt.

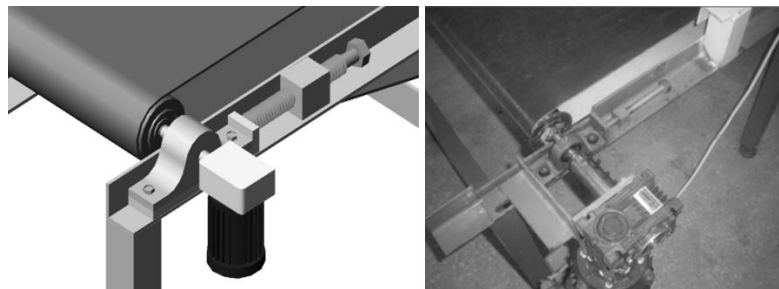

Figure 3. Three dimensional drawing and a picture of tension system

Driver unit

Belt was driven by an AC electric motor (Figure 4). In the control panel and drive unit, a start and stop button, 0.4 kW AC electric motor, contactor, motor protection switch, 0.25kW reducer (ratio:

1/21), 24V- 4.5A power supply and a polyester electric panel were used. Electric motor was directly joined to one of the rollers. Reducer output was joined to roller shaft by screws to give the rotational motion to this driving roller.



A- Electrical motor B-Band conveyor
Figure 4. Picture of driver unit

Control Unit

The work principle of the belt scale is based on measuring the speed of the belt and the load transferred on the belt. For this reason, an electronic board and a control unit including a LCD screen are used. The speed data transmitted by tachometer and the weight records sent by load cell were used to get total mass flow rate of the

crops. The capacity was shown as (kg s^{-1}) or (th^{-1}) and the speed was shown as (ms^{-1}) on a LCD screen either simultaneously or cumulative. Control unit was amplifying the signal by several filtering and linearization processes (Fig. 5). Technical properties of control unit was shown in Table 2.

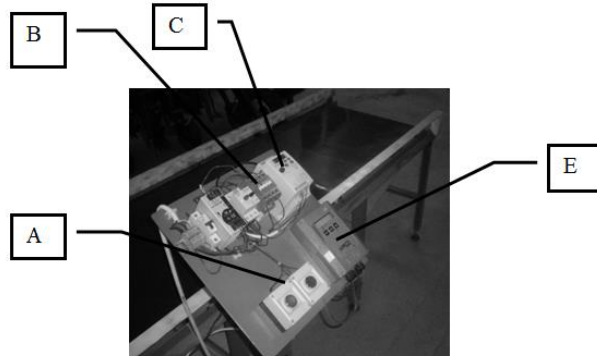

A: Start-stop buttons B: Contactor C: Frequency Inverter D: LCD screen E: Control Unit
Figure 5. Electric panel of belt scale

Table 2. Technical Properties of Control Unit

| Technical Properties | Data |
|----------------------------|--------------------------|
| Model | LCA-BS |
| Input | DC, -1.60 +1.6 Volt |
| Measuring speed (/seconds) | 50 |
| Load cell power supply | 10 VDC de 250 mA |
| Weighing accuracy | 10000d |

Nuts are mounted on the legs for balance and adjustable bolted legs were joined to the nuts to make the balance easier. A smoothed surface, 2.5 mm thickness, 77 shore. A hardness yellow PVC belt was used. There are three types of rollers used in the belt scale: support rollers, tension

roller and load cell roller. All rollers were produced from 50.8 mm (2") steel tube profile. In both sides of the rollers, roller bearings were used and the bearings mounted with 20 mm steel profile. Several 10.5 mm x10.5 mm slots were placed on the chassis in order to place the rollers

on the chassis. The slots also allow the roller to rotate around themselves. Totally 9 rollers are used. One of them is used for load cell, another one is used for tension of the band and the rest is used for supporting the belt.

Two basic parameters are used to measure flow rate of the mass during the motion of the belt. One is the speed of the belt and second is the weight measured by load cell (Figure 5).

A measuring area were defined in order to get the weight data. The distance between the left and right rollers and the load cell is kept equal. This distance is defined as measuring distance. Thus the weight transmitted by load cell becomes the weight per unit meter (Yildiran 1991).

$$MF = A \cdot v$$

(1)

MF=Mass flow rate (kgs^{-1})

A=Weight per unit meter (kgm^{-1})

v = Belt speed (ms^{-1})

The control unit also gives the measuring figures as kg, kg/s, t/h, kg/m and m/s on LCD screen. When the belt is stationary, the speed data transmitted by tachometer becomes zero. In this case, only the weight data on measuring area was available. Therefore a stationary belt scale becomes a standard scale. One single point load cell was used in the system and the load cell was joined to only one roller to get the weight data. The sum of the two 500 mm length on the left side and right side of the roller is defined as measuring distance. The weight data in 1000 mm distance was transmitted by load cell. Thus the weight per unit meter was sent to control unit and displaced on LCD screen. The effective measuring area was shown in the Figure 6.

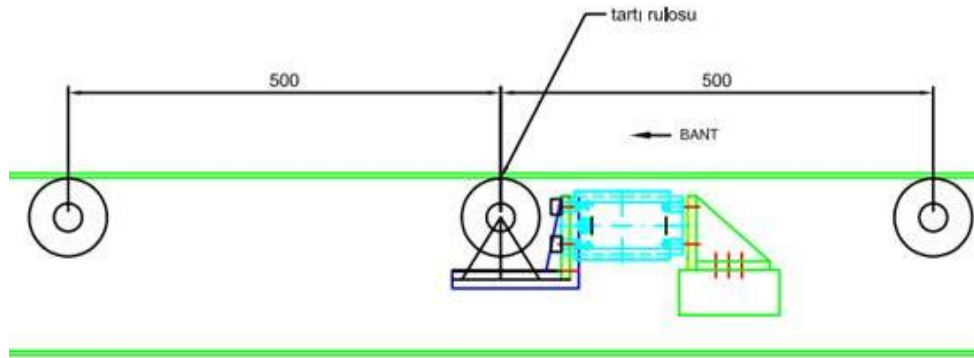

Figure 6. Weight roller and effective measuring area

Belt conveyor was basically divided into three segments: input section, weighing section and output section. Gathering weight data was occurred in weighing section. The length of the weighing area was set as 1000 mm therefore the

data obtained in the weighing area was the weight per unit length. The multiplication of this value by speed of the belt gives the mass flow rate (Figure 7).

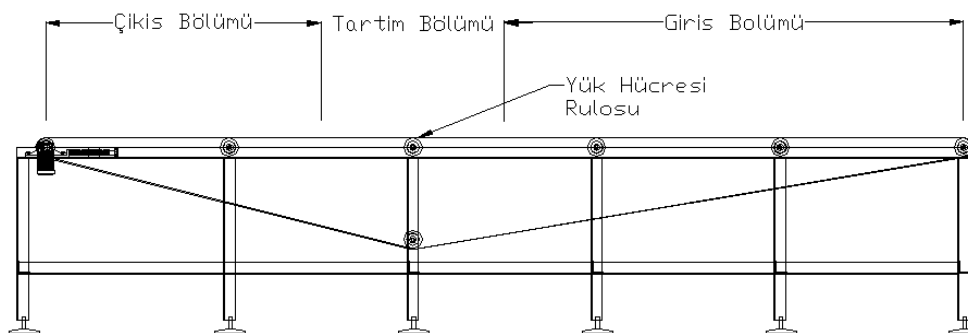

Figure 7. Sectional drawing of the measuring system

Following parameters were set for measuring process:

a - Wheel step distance: The distance elapsed per signal output, set as 45 mm

b - Weighing length: sum of equal distance on both sides of the load cell roller, set as 1000 mm

c - Speed: set as zero to transmit the dynamic speed data by tachometer

Signal timeout: timeout duration for the signal transmitted by tachometer, exceeding this value means the belt is stopped.

Weight calibration method

In order to get the correct information from the system two calibration processes should be performed. The first one is "zero" calibration. The other is "load" calibration. In zero calibration, the blank weight of the belt is recorded during unloaded position of the belt. Before zero calibration, the belt was worked at nominal speed and cycle time was calculated. Cycle time was calculated as 34 s at 50 Hz. In order to avoid the external effects to the system and including the parameters that may cause incorrect data during the motion, the belt was worked for 3 times. During this calibration process the system executes an internal enumeration and calculates oscillations, behaviour of the belt and approaches zero point. During the calibration, the belt is protected from external effects that may cause errors.

The second calibration is the load calibration. A test weight is used for this aim. The weight is

loaded to the belt and the value of the weight which was 5 kg is recorded to the system for reference. During this calibration process the system executes an internal enumeration and calculates oscillations and behaviour of the belt. During the calibration, the belt is protected from external effects that may cause errors as done in zero calibration.

Belt speed measurement method

Belt speed was calculated by control unit using the electrical signal coming from tachometer. The system was tested at different speeds by using a frequency inverter. The speed data is also cross checked and verified by speed formula. For this reason, a reference point was defined on the belt. The time required to complete one cycle of the belt revolution was recorded by a chronometer. Dividing the belt distance to cycle time gives the speed of the belt. This process was repeated at each trial during the weighing of the crops in order to find whether there is an slipping issue between the tachometer and the belt. The frequency inverter showed 0.23255 ms^{-1} at 50 Hz which reflects 2.3% error by comparing the speed calculated by speed formulae. However considering the possibility of measuring error due to the manual measuring methods and the precision of the data taken from chronometer, it is observed that the tachometer gives the speed value with high accuracy. The speed values recorded at different frequencies were given in Table 3.

Table 3. Speed data at different frequencies

| Frequency [Hz] | Tachometer speed [ms^{-1}] | Calculated speed [ms^{-1}] | Error [%] |
|----------------|---------------------------------------|---------------------------------------|-----------|
| 50 | 0.23255 | 0.232941 | 2.3 |
| 40 | 0.18132 | 0.186760 | 2.3 |
| 30 | 0.13387 | 0.133870 | 2.1 |

Method of the weighing system

Potatoes and onions were used in the study. 15 kg and 10 kg crops were tested for potato and onions, respectively. Potatoes were tested at 3 different speed values. 15 kg Potatoes were loaded to the belt 5 times thus total 75 kg potato was passed across the belt during measuring time. Crops were loaded from the input section of the belt and the crops were collected at the output section of the belt. They were re-loaded in order to get a uniform load distribution during the motion of the belt. Data were recorded for three

different belt speeds (0.23255 ms^{-1} at 50 Hz, 0.18132 ms^{-1} at 40 Hz, 0.13387 ms^{-1} at 30 Hz).

After constructing and running the system, potatoes were used to get data first. Potatoes were loaded into the input section of the belt and transferred to weighing section by the belt. Measuring distance was defined as 1 m. The weight data taken from this section were transmitted to control unit, displaced on the LCD screen were recorded (Figure 8). Every 15 kg batch of potato and every 10 kg batch of onion were passed across the belt 3 times.



Figure 8. Weighing of potatoes and onions

Two different weight descriptions were defined: instant weight and cumulative weight. Instant weight was defined as the weight data given by load cell per unit seconds. Cumulative weight was defined as the sum of the previous weight data with current weight data. Thus it was aimed to compare the loaded weight with calculated weight by the system. Accuracy ratio of the system data was calculated by given formulae:

$$A = \frac{w_l}{w_m} \cdot 100 \quad (2)$$

A= Accuracy ratio of the measuring (%)

w_l= Weight loaded (kg)

w_m= Weight measured (kg)

Obtained data related to each measuring time was given in below tables in which belt speed;

instant weight and cumulative weight were tabulated.

RESULTS AND DISCUSSIONS

Accuracy of measuring system in stationary position of the belt

When the belt was stationary, the weight of the 15 kg and 10 kg test materials were transmitted to the LCD screen by zero error. The belt scale becomes a high precise scale during stationary position.

Accuracy of measuring system in running position of the belt for potatoes

Findings for potato at 50 Hz and 0.23255 ms⁻¹ were given in Table 4, findings at 40 Hz and 0.18132 ms⁻¹ were given in Table 5, and findings at 30 Hz and 0.13387 ms⁻¹ are given in Table 6.

Accuracy of the measurement in different speed values for potato tests are given Table 7.

Result shows that the accuracy ratio was calculated as 97.43% on average for potatoes.

Table 4. Potato weighing table (Frequency: 50Hz – Belt speed: 0.23255 ms⁻¹)

| Time (s) | Instant weight (kg) | Cumulative weight (kg) |
|----------|---------------------|------------------------|
| 0 | 6.60 | 6.60 |
| 2 | 5.93 | 12.53 |
| 4 | 6.87 | 19.40 |
| 6 | 7.05 | 26.45 |
| 8 | 7.02 | 33.47 |
| 10 | 6.06 | 39.53 |
| 12 | 6.90 | 46.43 |
| 14 | 6.52 | 52.95 |
| 16 | 5.43 | 58.38 |
| 18 | 6.12 | 64.50 |
| 20 | 6.76 | 71.26 |

Table 5. Potato weighing table (Frequency: 40Hz – Belt speed: 0.18132 ms⁻¹)

| Time (s) | Instant weight (kg) | Cumulative weight (kg) |
|----------|---------------------|------------------------|
| 0 | 6.82 | 6.82 |
| 2 | 6.67 | 13.49 |
| 4 | 7.09 | 20.58 |
| 6 | 6.88 | 27.46 |
| 8 | 6.77 | 34.23 |
| 10 | 5.98 | 40.21 |
| 12 | 6.54 | 46.75 |
| 14 | 7.04 | 53.79 |
| 16 | 6.39 | 60.18 |
| 18 | 6.82 | 67.00 |
| 20 | 6.90 | 73.90 |

Table 6. Potato weighing table (Frequency: 30Hz – Belt speed: 0.13387 ms⁻¹)

| Time (s) | Instant weight (kg) | Cumulative weight (kg) |
|----------|---------------------|------------------------|
| 0 | 7.00 | 7.00 |
| 2 | 6.81 | 13.81 |
| 4 | 6.89 | 20.70 |
| 6 | 7.08 | 27.78 |
| 8 | 6.23 | 34.01 |
| 10 | 7.00 | 41.01 |
| 12 | 6.76 | 47.77 |
| 14 | 6.06 | 53.83 |
| 16 | 7.08 | 60.91 |
| 18 | 6.09 | 67.00 |
| 20 | 7.13 | 74.13 |

Table 7. Accuracy of the measurement for potato

| Speed (ms ⁻¹) | Measured value (kg) | Actual value (kg) | Accuracy of measurement (%) |
|---------------------------|---------------------|-------------------|-----------------------------|
| 0.23255 | 71.26 | 75 | 95.00 |
| 0.18132 | 73.90 | 75 | 98.50 |
| 0.13387 | 74.13 | 75 | 98.80 |
| Average | 73.09 | 75 | 97.43 |

Accuracy of measuring system in running position of the belt for onions

Onions were tested at 3 different speed values and the results were discussed below. Onions weighing 10 kg are loaded to the belt 5 times thus total 50 kg onion was passed across the belt

during measuring time. Findings for onions at 50 Hz and 0.23255 ms⁻¹ were given in Table 8, findings at 40 Hz and 0.18132 ms⁻¹ were given in Table 9, and findings at 30 Hz and 0.13387 ms⁻¹ were given in Table 10.

Table 8. Onion weighing table (Frequency: 50Hz – Belt speed: 0.23255 ms⁻¹)

| Time (s) | Instant weight (kg) | Cumulative weight (kg) |
|----------|---------------------|------------------------|
| 0 | 3.76 | 3.76 |
| 2 | 4.56 | 8.32 |
| 4 | 4.87 | 13.19 |
| 6 | 4.33 | 17.52 |
| 8 | 3.56 | 21.08 |
| 10 | 4.00 | 25.08 |
| 12 | 4.60 | 29.68 |
| 14 | 5.01 | 34.69 |
| 16 | 5.32 | 40.01 |
| 18 | 3.90 | 43.91 |
| 20 | 3.12 | 47.03 |

Table 9. Onion weighing table (Frequency: 40Hz – Belt scale: 0.18132 ms⁻¹)

| Time (s) | Instant weight (kg) | Cumulative weight (kg) |
|----------|---------------------|------------------------|
| 0 | 4.56 | 4.56 |
| 2 | 3.55 | 8.11 |
| 4 | 3.33 | 11.44 |
| 6 | 4.57 | 16.01 |
| 8 | 5.01 | 21.02 |
| 10 | 5.32 | 26.34 |
| 12 | 4.08 | 30.42 |
| 14 | 4.48 | 34.90 |
| 16 | 3.98 | 38.88 |
| 18 | 4.81 | 43.69 |
| 20 | 4.45 | 48.14 |

Table 10. Onion weighing table (Frequency: 30Hz – Belt speed: 0.13387 ms⁻¹)

| Time (s) | Instant weight (kg) | Cumulative weight (kg) |
|----------|---------------------|------------------------|
| 0 | 4.18 | 4.67 |
| 2 | 4.67 | 8.85 |
| 4 | 4.32 | 13.17 |
| 6 | 3.97 | 17.14 |
| 8 | 4.79 | 21.93 |
| 10 | 4.58 | 26.51 |
| 12 | 4.78 | 31.29 |
| 14 | 4.19 | 35.48 |
| 16 | 4.93 | 40.41 |
| 18 | 4.55 | 44.96 |
| 20 | 4.43 | 49.39 |

Accuracies of the measurement in different speed values for onion tests were given Table 11.

Result shows that the accuracy ratio was calculated as 96.37% on average for onions.

Table 11. Accuracy of the measurement for onion

| Speed (m.s ⁻¹) | Measured value (kg) | Actual value (kg) | Accuracy of measurement (%) |
|----------------------------|---------------------|-------------------|-----------------------------|
| 0.23255 | 47.03 | 50 | 94,00 |
| 0.18132 | 48.14 | 50 | 96,30 |
| 0.13387 | 49.39 | 50 | 98,80 |
| Average | 48.18 | 50 | 96.37 |

Conclusions

The weight of the potatoes and onions used in the study were estimated with the accuracy of 97.5% and 96.4% respectively. The study showed that the weight of the tuber crops can be accurately measured on a belt scale. This accuracy ratio can be improved by more stable mechanical construction and assembly of the system. Alignment of PVC band, stability of steel construction against to mechanical vibrations, stability of joints between the chassis and load cell, taper angle of outer surface of the rollers and prevention of slippage between the PVC band and the rollers area the basic parameters to get a better accuracy.

The tachometer transmitted the speed data to the control unit with high accuracy. The speed data received from the control unit showed that the belt speed remains constant during the motion and there were no sliding of the belt. The mechanical properties of the tachometer were suitable for continuous running of the belt scale. Therefore the tachometer can be used effectively considering difficult working environment in agricultural industries. The contact between the belt and tachometer was maintained by placing the tachometer on top of the belt thus possible sliding of the belt on the tachometer is avoided. Therefore the incorrect data that can be transmitted by tachometer due to the dynamic loads on the belt was prevented. Tension system on the belt scale becomes a necessity due to the getting correct weighing by adjusting a suitable belt tension. Especially in zero and load calibration, the adjustment of the tension system was affecting the data accuracy directly. In order to prevent the belt sliding over the rollers during the motion, a tapered shape was given to both sides of the rollers. Undesired sliding of the belt over the roller creates extra forces on the belt therefore it should be avoided. The assembly of the roller on the chassis of the system and the precision of the outer diameters of the roller were also an important parameter that can negatively affect the accuracy of measuring.

Acknowledgements

This paper was prepared from the project "Development of a measurement system for weighing of tuber crops on a conveyor band –in Turkish:Hareket Halindeki Bir Bantlı Konveyör Üzerinde Yumru Bitkilerine Ait Ağırlık Ölçme Sisteminin Geliştirilmesi-Project no: NKUBAP.00.24.YL.09.13. supported by Namik Kemal University. Authors would like to thanks to Namik Kemal University.

References

- Algerbo, P. A., Ehlert, D. 2000. Evaluation of yield sensing systems for potato harvesters. Proceedings of the 5th International Conference on Precision Agriculture, Bloomington, Minnesota, USA, 16-19 July, 2000: p.1-10
- Demmel, M., Auernhammer, H. 1999. Local Yield Measurement in a Potato Harvester and Overall Yield Patterns in a Cereal-Potato Crop Rotation, 1999 ASAE/CSAE-SCGR Annual International Meeting Toronto, Ontario Canada, July 18-21, 1999 , An ASAE Meeting Presentation Paper No. 99 11 49
- Ehlert, D. 2000. Measuring mass flow by bounce plate for yield mapping of potatoes. Precision Agriculture. 2: 119-130
- Fisher, S., Jaggard, K., Stafford, J. 1997. Precision farming for sugar beet. *British Sugar Beet Review* 65(4):29-31.
- Hall, T., Backer, L., Hofman, F., Smith, L. J. 1998. Evaluation of sugar beet yield sensing systems operating concurrently on a harvester. Proceedings of the Fourth International Conference on Precision Agriculture, St. Paul, Minnesota, USA., p.1107-1118
- Sulak, A. I. 1993. Design of a loaded with band worked with tractor (In Turkish: Tarım Traktörleri İle Çalıştırılabilen Bantlı Bir Yükleyicinin Projelendirilmesi). MSc Thesis. Selçuk University, Konya. Turkey
- Yildiran, D. 1991. Principles of conveyor band applications (in Turkish: Konveyör Bant Kantarı Uygulama Prensipleri). *Mining Journal*, 30: 27-32
- Zamani, D. M., Ghoşamiparashkahi, M., Faghavi, A., Ghezavati, J.E. 2014. Design, implementation and evaluation of potato yield monitoring system, *International Journal of Technical Research and Applications* 2 (Special Issue 6): 36-39